



LOW PRESSURE DIAPHRAGM PUMPS



BP 60 K

2 Diaphragm

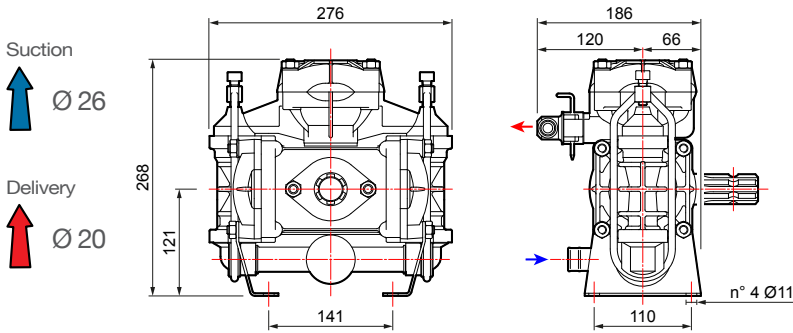

AVAILABLE MODELS

BP 60 S
30mm Solid Keyed Shaft

BP 60 SPL
1 3/8" Splined Shaft

BP 60 HYD
1" Hydraulic Drive



ACCESSORIES & REPAIR KITS

Comet Oil



8102.1801.00

GCP 3V Regulator



1204.0191.00

Shaft Protector



2416.0272.00

Rebuild Kit



NBR: 5026.0009.00

RPM	0 bar - 0 p.s.i.				5 bar - 72 p.s.i.				10 bar - 145 p.s.i.				15 bar - 217 p.s.i.				20 bar - 290 p.s.i.				kg lb	
	l/min	U.S.g.p.m.	HP	KW	l/min	U.S.g.p.m.	HP	KW	l/min	U.S.g.p.m.	HP	KW	l/min	U.S.g.p.m.	HP	KW	l/min	U.S.g.p.m.	HP	KW		
400	50	13.2	0.5	0.4	48	12.7	0.8	0.6	47	12.4	1.5	1.1	45	11.9	2.0	1.5	43	11.4	2.4	1.8	9.8	21.6
450	56	14.8	0.5	0.4	54	14.3	0.9	0.7	52	13.7	1.6	1.2	50	13.2	2.2	1.6	49	12.9	2.8	2.1		
500	61	16.1	0.6	0.4	59	15.6	1.0	0.7	57	15.1	1.8	1.3	55	14.5	2.5	1.8	54	14.3	3.1	2.3		
550	65	17.2	0.6	0.4	63	16.6	1.1	0.8	62	16.4	1.9	1.4	60	15.9	2.6	1.9	58	15.3	3.3	2.4		