



MEDIUM PRESSURE DIAPHRAGM PUMPS



MP 20

2 Diaphragm

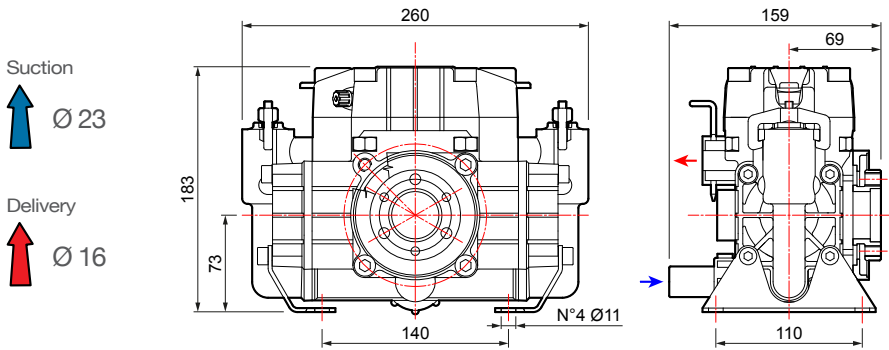

Control unit not included.

AVAILABLE MODELS

MP 20
6 Hole Flange



MP 20 P
10" 2A Groove Pulley
Adjustable Regulator



MP 20 HYD
1" Hydraulic Drive



ACCESSORIES & REPAIR KITS

Comet Oil



8102.1801.00

Sirius Regulator



1204.0560.00

Gearbox



5005.0216.00

Shaft Protector



2416.0297.00

Rebuild Kit



NBR: 5026.0080.00

RPM	0 bar - 0 p.s.i.				10 bar - 145 p.s.i.				20 bar - 290 p.s.i.				30 bar - 435 p.s.i.				kg / lb	
	l/min	U.S.g.p.m.	HP	kW	l/min	U.S.g.p.m.	HP	kW	l/min	U.S.g.p.m.	HP	kW	l/min	U.S.g.p.m.	HP	kW		
400	16.5	4.4	0.1	0.1	14.2	3.8	0.4	0.3	14.1	3.7	0.8	0.6	14.0	3.7	1.1	0.8	6.6	14.6
450	18.0	4.8	0.2	0.1	16.1	4.3	0.5	0.4	16.0	4.2	0.9	0.7	15.9	4.2	1.3	1.0		
500	20.2	5.3	0.2	0.1	18.0	4.8	0.6	0.4	17.8	4.7	1.0	0.7	17.7	4.7	1.4	1.0		
550	22.4	5.9	0.2	0.1	19.9	5.3	0.6	0.4	19.6	5.2	1.1	0.8	19.5	5.2	1.6	1.2		