



MEDIUM PRESSURE DIAPHRAGM PUMPS



MP 30

2 Diaphragm

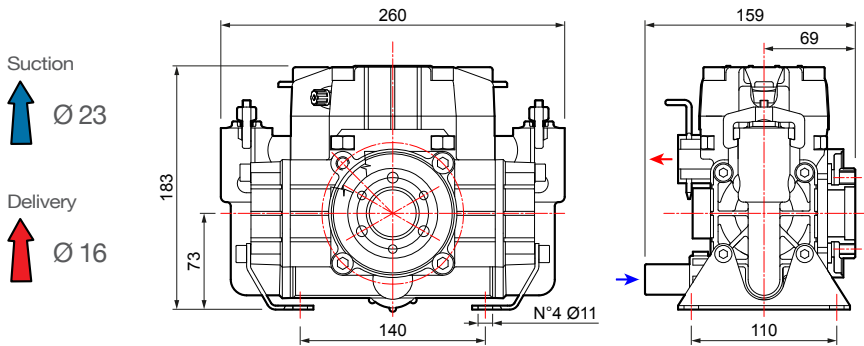

Control unit not included.

AVAILABLE MODELS

MP 30

6 Hole Flange



MP 30 GR

3/4" Hollow Shaft Gearbox



MP 30 P

10" 2A Groove Pulley Adjustable Regulator



MP 30 HYD

1" Hydraulic Drive



ACCESSORIES & REPAIR KITS

Comet Oil



8102.1801.00

Sirius Regulator



1204.0560.00

Gearbox



5005.0216.00

Shaft Protector



2416.0297.00

Rebuild Kit



NBR: 5026.0080.00

RPM	0 bar - 0 p.s.i.				10 bar - 145 p.s.i.				20 bar - 290 p.s.i.				30 bar - 435 p.s.i.				kg	lb
	l/min	U.S.g.p.m.	HP	kW	l/min	U.S.g.p.m.	HP	kW	l/min	U.S.g.p.m.	HP	kW	l/min	U.S.g.p.m.	HP	kW		
400	23.3	6.2	0.2	0.1	21.4	5.7	0.7	0.5	21.3	5.6	1.2	0.9	21.2	5.6	1.7	1.3	6.6	14.6
450	26.3	6.9	0.3	0.2	24.2	6.4	0.8	0.6	24.0	6.3	1.4	1.0	23.8	6.3	1.9	1.4		
500	29.3	7.7	0.3	0.2	26.9	7.1	0.8	0.6	26.6	7.0	1.5	1.1	26.4	7.0	2.1	1.5		
550	32.0	8.5	0.3	0.2	29.4	7.8	0.9	0.7	29.2	7.7	1.7	1.3	29.2	7.7	2.3	1.7		