

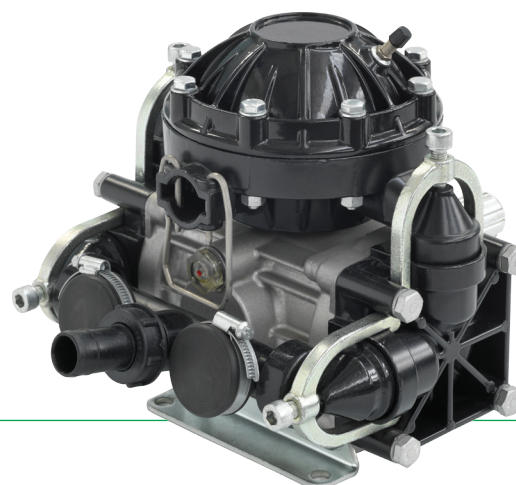

MEDIUM PRESSURE DIAPHRAGM PUMPS

P48

2 Diaphragm

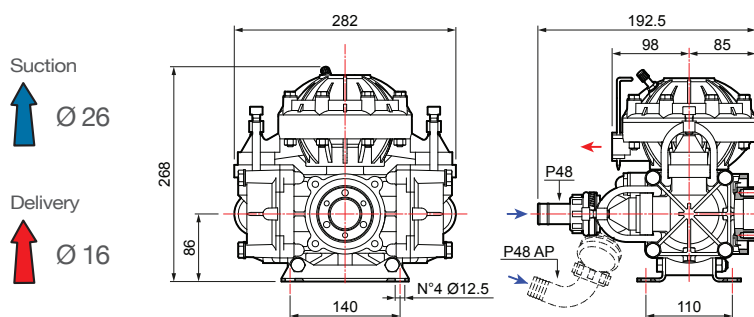

AVAILABLE MODELS

P 48
6 Hole Flange



P 48 P
10" 2A Groove Pulley
Adjustable Regulator



P 48 AP
6 Hole Flange
1" Solid Keyed Shaft



ACCESSORIES & REPAIR KITS

Additional accessories available, see page 32.

Comet Oil



8102.1801.00

GCP 3V Regulator



1204.0195.00

Gearbox



5005.0216.00

Shaft Protector



2416.0297.00

Rebuild Kit



NBR: 5026.0079.00

RPM	0 bar - 0 p.s.i				10 bar - 145 p.s.i				20 bar - 290 p.s.i				30 bar - 435 p.s.i				kg / lb	
	l/min	U.S.g.p.m.	HP	kW	l/min	U.S.g.p.m.	HP	kW	l/min	U.S.g.p.m.	HP	kW	l/min	U.S.g.p.m.	HP	kW		
400	39.7	10.5	0.4	0.3	35.6	9.4	1.1	0.8	34.4	9.1	2.0	1.5	33.8	8.9	2.7	2.0	12.5	27.6
450	48.8	12.8	0.4	0.3	41.6	11.0	1.3	1.0	40.7	10.8	2.3	1.7	40.0	10.6	3.2	2.4		
500	57.8	15.3	0.5	0.4	47.6	12.6	1.5	1.1	47.0	12.4	2.7	2.0	46.3	12.2	3.7	2.7		
550	64.2	17.0	0.6	0.4	53.0	14.0	1.7	1.3	52.3	13.8	3.0	2.2	51.7	13.7	4.1	3.0		