



## Electronic 7 - Day Time Switches

With 2 Independent Outputs and  
Battery Powered Clock Operation

## ET270 SERIES

INCLUDING MODELS:

ET279C (SPST each output)  
120V Supply

# OWNER/INSTALLER INSTRUCTION MANUAL

**ATTENTION: READ CAREFULLY BEFORE ATTEMPTING TO INSTALL YOUR INTERMATIC TIME SWITCH. FAILURE TO COMPLY WITH INSTRUCTIONS COULD RESULT IN PERSONAL INJURY AND/OR PROPERTY DAMAGE! RETAIN FOR FUTURE REFERENCE.**

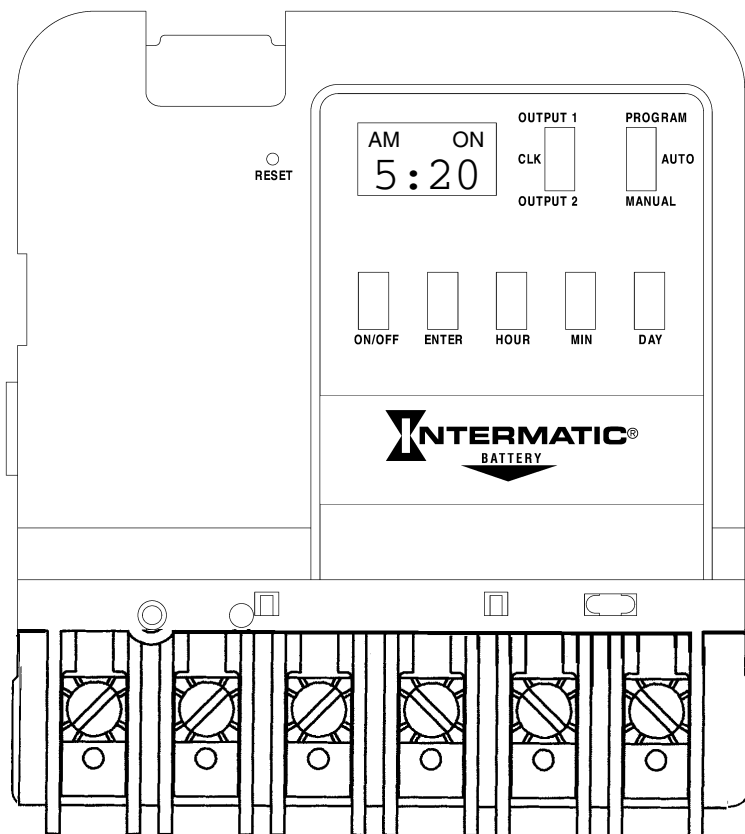

### Description

The Intermatic Electronic 7-Day Time Switch automatically switches 2 loads independently according to a preset weekly schedule with to-the-minute accuracy. This time switch is designed to directly switch resistive or inductive loads up to 30 amps at 24, 120 or 240 volts and to switch tungsten or ballast loads up to the time switch rating. For use as a control timer in applications requiring 7-day load control such as lighting, heating, air conditioning systems, pumps, etcetera. Up to 20 (10 ON/10 OFF or any combination or 20 momentary pulse operation) can be preset. These set points can be programmed for any or all 7 days to provide for up to 140 set points or pulse operations each week. Independent 2 load 7 day programming provides complete flexibility for applications where load switching differs each day of the week. The program can be overridden by selecting the MANUAL position.

### Specifications

CLOCK VOLTAGE: 120 V.A.C., 60 Hz.

POWER CONSUMPTION: 5.0 Watts Max.

CONTACT CONFIGURATION: SPST for output 1 and 2

SWITCH RATING: (Per Pole)

- 30 Amps Inductive/Resistive, 24/120/240 V.A.C., 60 Hz.
- 20 Amps Resistive - 28 V.D.C.,
- 1 H.P. 120 V.A.C., 60 Hz.
- 2 H.P. 240 V.A.C., 60 Hz.
- 5 Amps Tungsten, 120/240 V.A.C., 60 Hz.
- 20 Amps Ballast 277 V.A.C., 60 Hz.

SET POINTS (EVENTS): 20 total for both outputs combined in any combination (10 ON/10 OFF or any combination or 20 momentary pulse operations) daily.

Up to 140 (70 ON/70 OFF or any combination or 140 pulse operations) weekly.

BATTERY POWERED CLOCK OPERATION: 3 Years minimum (AA industrial grade alkaline supplied with time switch)

MIN. "ON" or "OFF" TIME: 1 minute.

MAX. "ON" or "OFF" TIME: 6 days 23 hours 59 minutes.

SHIPPING WEIGHT: 2.5 Lbs. (1.1 Kg)

CASE: Drawn steel; 7-3/4" (19.7 cm) high, 5" (12.7 cm) wide, 3" (7.6 cm) deep; gray finish w/lockable spring hasp.

KNOCKOUTS: Combination 1/2 - 3/4" (one on back and each side, two on bottom).

WIRE SIZE: AWG #10 through #18.

### General Safety Information

**WARNING:** Disconnect all power before installing or servicing this time switch or its connected loads.

1. Follow all local electrical and safety codes, National Electric Code (NEC), as well as Occupational Safety and Health Act (OSHA).
2. If the power disconnect point is out of sight, lock it in the "OFF" position and tag it to prevent unexpected application of power.
3. This time switch case must be grounded.
4. Do not exceed the maximum current carrying capacity of this time switch.
5. Always replace the plastic insulator covering the terminal before turning power "ON".

### Installation

**WARNING:** DISCONNECT THE POWER TO THE TIME SWITCH AND THE LOADS BEFORE INSTALLING THIS TIME SWITCH.

1. Mount the time switch in the desired location using the three mounting holes which are provided. Mount the time switch at eye level, if possible, providing sufficient room to the left of the

enclosure for the cover to swing open fully. (See Figure #1 and Figure #2). The time switch mechanism does not need to be removed from the enclosure to mount the time switch since the top mounting hole is a slotted type mounting hole. Secure a screw or other fastener at eye level. The head of the screw or fastener should be slightly larger than the narrow portion of the slotted hole to ensure that the time switch is securely held in place. The remaining two mounting holes are accessible without removing the time switch mechanism and will provide secure and permanent mounting of the time switch.

2. To select momentary pulse operation you must remove the time switch mechanism. Jumpers for selecting momentary operation are enclosed, along with installation instructions in the plastic bag. If you do remove the mechanism, refer to Figure #1 and remove the mechanism from the case by depressing the catch at the top of the case and pulling out.

**CAUTION: DO NOT TOUCH THE CIRCUIT BOARD COMPONENTS SINCE STATIC DISCHARGE COULD DAMAGE THE MICROPROCESSOR.**

3. Replace the mechanism in the case if it has been removed.

4. Lift the left side of the insulator off of the retaining post and pivot it up and away to expose the terminal strip.

5. Strip the supply and load wires by removing 1/2 inch of insulation. **DO NOT USE ALUMINUM WIRE.** (See figure #3, #4 or #5). Insert the wire ends under the proper terminal plates and tighten the screws firmly. Use AWG #10 through #18. Connect ground wire to grounding terminal at bottom of case.

6. Replace the plastic insulator.

7. Be sure that the battery is functioning properly. This can be checked by making sure the display is visible. If the display has scrambled information, press the RESET switch and hold for three to five seconds. Note that the battery can easily be replaced without removing the time switch mechanism or field wiring. Simply press in and down ward (in the direction of the arrow) on the battery cover which is identified with the word "Battery". It is recommended that the battery be replaced with a "AA" industrial grade alkaline cell at two to three year intervals as part of the normal time switch maintenance observing battery polarity markings when installing. No other maintenance is required.

8. Place the selector switches in the AUTO and CLK position.

9. Reapply power to the time switch.

10. Press the reset switch for three to five seconds. The display will now show 12:00 A.M. and day #1. Note that the days of the week are numbered 1 through 7 for Sunday through Saturday. The timer is now ready for programming. Refer to the chart which follows and enter the scheduled events (set points or pulse outputs) required. Assign each of the 20 set points (EVENTS) entered to whichever day or days of the week you wish an ON or OFF operation to occur. Simply put a check in the box that applies. Note that programming two off times in sequence, allows the user to manually turn a load on, after normal working hours for example, and allows the time switch to automatically turn the load back off. This is an energy saving feature which allows loads to be manually switched on after normal occupancy times, but provides for automatic off switching of these loads. Note that several off times in a row can be programmed to provide several "auto off" times.

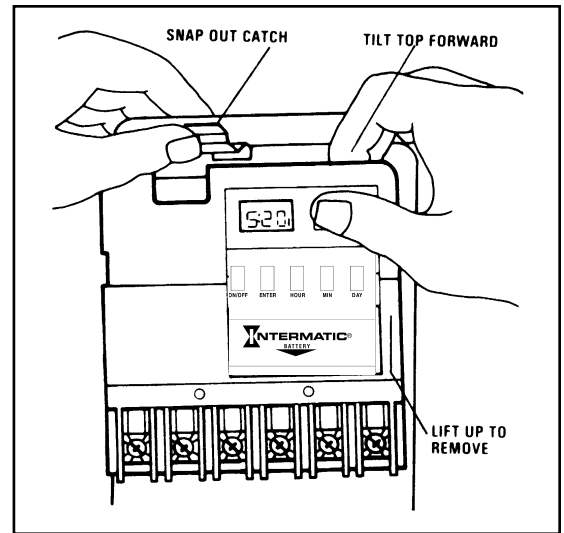

FIG. #1

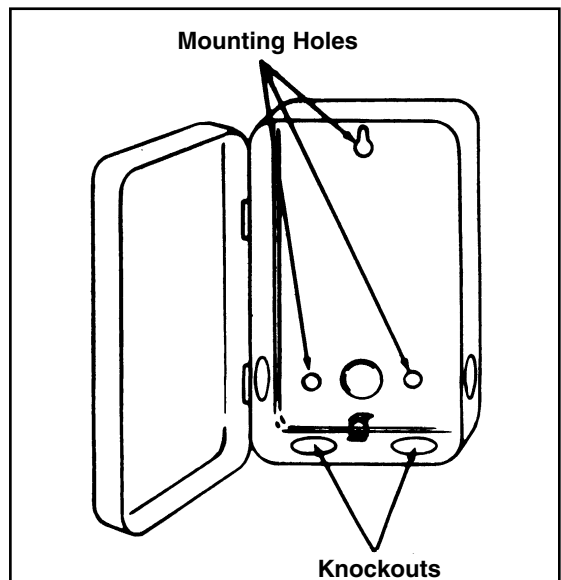
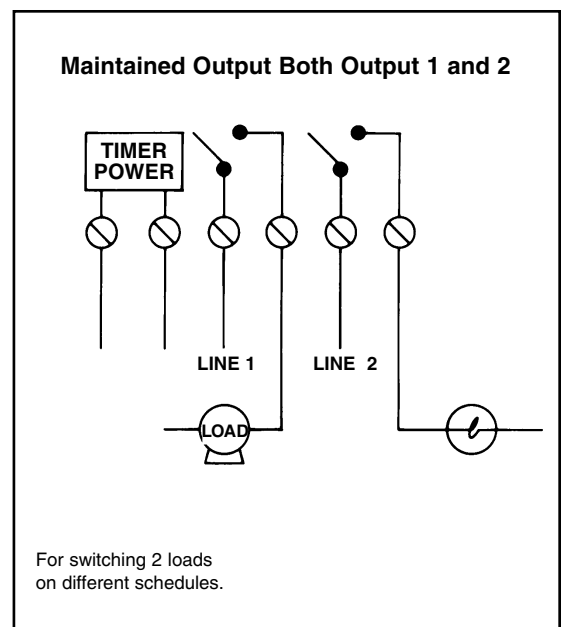

FIG. #2



For switching 2 loads on different schedules.

FIG. #3

## DAY

EVENT	SWITCHING TIMES	"ON" OR "OFF" OPERATION	DAY						
			SUN. 1	MON. 2	TUES. 3	WED. 4	THUR. 5	FRI. 6	SAT. 7
1									
2									
3									
4									
5									
6									
7									
8									
9									
10									
11									
12									
13									
14									
15									
16									
17									
18									
19									
20									

### Programming Steps

Refer to programming instructions in this manual or the abbreviated instructions on time switch door label and note the following:

- The slide switch located on the right side is used to select automatic operation (AUTO), manual operation (MANUAL) or to select programming (PROGRAM). The MANUAL position can be used to temporarily override the program. Under normal operation, the selector should be in the AUTO mode. The MANUAL mode maintains the program but prevents the loads from automatically switching. **FOR A PROGRAM TO SWITCH LOADS AT THE CORRECT TIMES, THE SELECTOR SWITCH MUST BE IN THE AUTO POSITION.**
- The left selector switch is used to select programming for the time of day and day of week (CLK) or select programming for the switching times (for both outputs independently OUTPUT1 or OUTPUT 2).
- The RESET switch is used only prior to programming to reset the microprocessor or to erase all programmed set points.
- By holding the hour and/or minute buttons depressed, you can achieve a fast roll of the displayed time. This is useful when setting the time of day or programming set points (EVENTS).
- UP to 10 ON and 10 OFF set points for both outputs combined or any combination up to 20 set points (EVENTS or momentary pulses) can be programmed and can be assigned to any or all 7 days for up to a maximum of 140 set points or pulses each week.
- The load can be manually switched ON or OFF at any time if the selector switch is in either the MANUAL or AUTO mode by pressing the ON/OFF button. The left selector MUST BE IN OUTPUT 1 or OUTPUT 2 MODE.
- Pressing the ON/OFF button two times in the PROGRAM mode causes the event time displayed to be removed from the program. The display will show "--:--".

### Programming

**RESET TIME SWITCH:** Press the recessed RESET switch to reset the microprocessor and delete any set point information which has been programmed. NOTE: DO NOT press RESET after programming has begun or you will lose all of your program information.

**TO SET TIME AND DAY OF WEEK:** Place the right three position selector in PROGRAM and the two left three position selector in CLK mode. Press the HOUR, MINUTE and DAY buttons individually to select the current time of day (12 hour AM/PM repeating) and the day of the week. Day 1 is Sunday, day 2 is Monday, etc.

**TO PROGRAM SET POINTS:** Select PROGRAM mode with the right selector and OUTPUT 1 or OUTPUT 2 mode with the left selector. Press the HOUR and MINUTE buttons separately to program the first set point time desired. Press the DAY button to select the day the

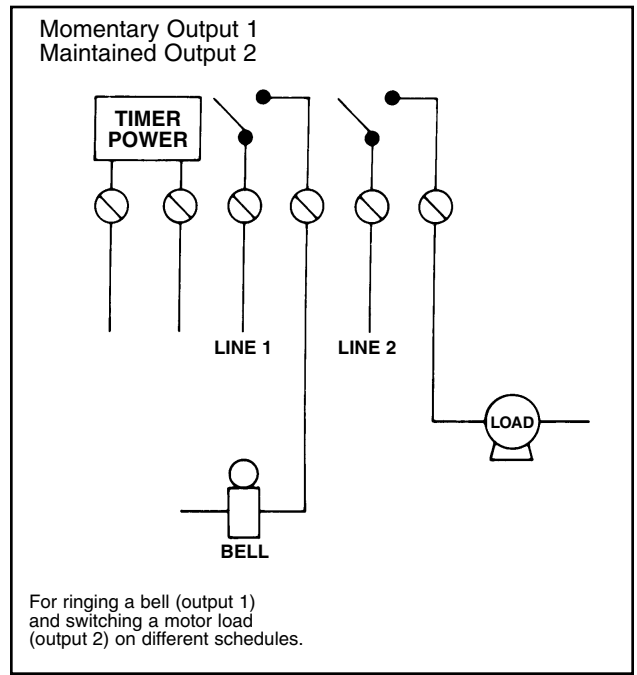

FIG. #4

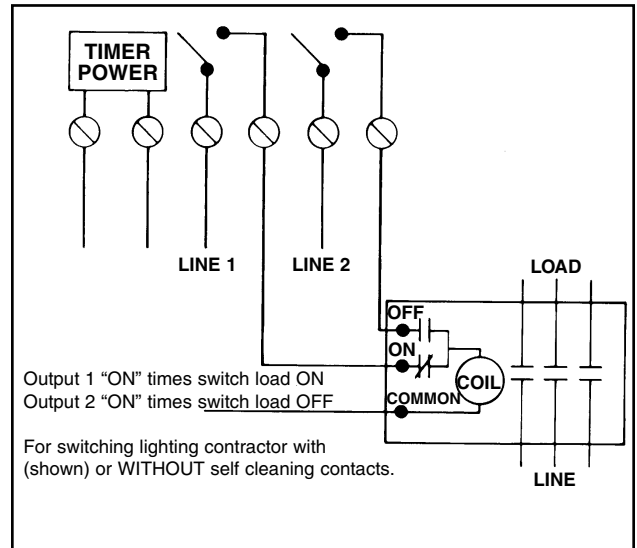

FIG. #5

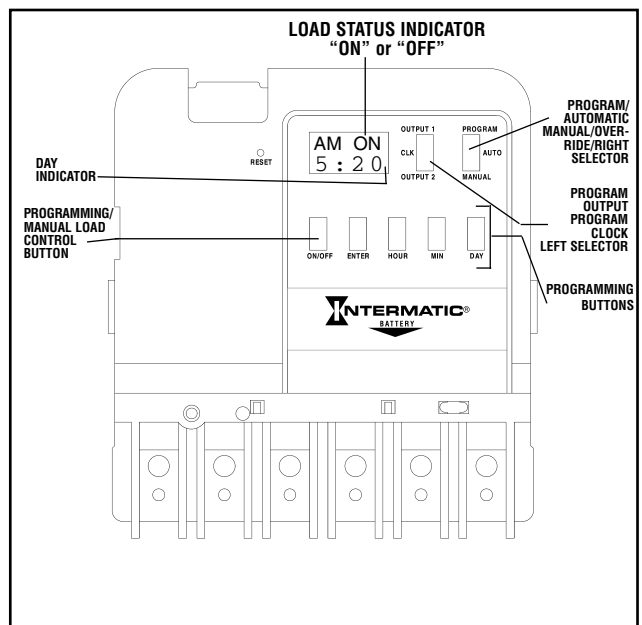

FIG. #6

Event is to occur. Press the ON/OFF button to select an ON or OFF set point. Note that if momentary output has been selected for either OUTPUT 1 or 2 only ON set points will be displayed. Press the ENTER button to enter that set point for the selected day. Note that the ON or OFF indicator stops flashing only after pressing ENTER. If this set point is to occur for other days of the week, simply press the DAY button to select the next day then ENTER. Repeat for any additional days. Note that this allows you to utilize one set point for any or all days of the week. A total of 20 set points are provided allowing up to 140 operations each week (20 set points X 7 days = 140 operations). Repeat this procedure for as many of the 20 set points as required. Attempts to enter additional set points (beyond 20) will cause "F:UL" to appear in the display.

**TO OVERRIDE PROGRAM:** Program can be overridden at any time by selecting the MANUAL position. Program set points will be maintained but will not operate the controlled load(s) automatically.

**TO REVIEW PROGRAM SET POINTS:** Place the right selector in the PROGRAM mode. Place the left selector in OUTPUT 1 or OUTPUT2 mode. The display will show all zeros if there are no set points programmed or will show the first programmed set point and a programmed time with an ON or OFF depending on whether the time which appears is an ON set point or an OFF set

point. Note that only ON set points will appear if the momentary pulse feature has been selected. Pressing the ENTER button will advance the display to the next set point in chronological order. In other words, the next set point on Sunday or the set point on Monday (day 2) will appear. Pressing the ENTER first button after the last set point has been displayed will cause "E: nd" to appear in the display. Further operation of the ENTER button will repeat the review cycle.

**TO ADD OR DELETE SET POINTS:** Press the HOUR and/or MINUTE buttons to change the time displayed to show the new time you wish to add, then press the ENTER pushbutton. To remove a programmed time, press the ON/OFF button two times. When this is done, the set point displayed will be removed and the display will show all dashes.

**TO OPERATE TIMER**  
After programming is complete, move the selector switches to the CLK and AUTO positions. The time switch will follow the scheduled program but will not immediately "catch up" to the presently programmed load condition; the time switch will "catch up" at the next scheduled ON or OFF setpoint. If necessary, press the ON/OFF button to turn the load on or off.

### **Trouble Shooting**

SYMPTOM	POSSIBLE CAUSE(S)	CORRECTIVE ACTION
Time switch has no display.	Battery not properly installed or defective.	Check battery and replace if necessary.
Display shows "L-bA".	Display means "Low Battery".	Replace battery within 30 days.
Display shows "Err 1" message. Display shows "Err 2" message. Display shows "Err 3" message.	Slide switch not fully in its detent position (open circuit). Slide switch shorted circuit. Slide switch illegal position.	Reposition slide switch into detent or "wiggle" until display is corrected. If display does not correct, contact or return to factory for service.
Display shows scrambled or erratic times.	Time switch has not been reset.  Electrical noise is interfering with the operation of the microprocessor.	Press the recessed reset switch and hold for approximately 5 seconds. Electrical noise interference is highly unlikely since the electronic circuitry and the power supply are completely isolated. The installation of surge suppressors (metal oxide varistors-MOVs) across terminals 3/4 & 5/6 will help to reduce electrical noise generated at the switching contacts.
Load does not switch at-programmed time.	PROGRAM/MANUAL/AUTO selector not in AUTO position. Time switch is programmed incorrectly, or program times are assigned to wrong output Power has not been supplied to the load. Note that the Neutral and Line output terminals.	Be sure MANUAL./AUTO is in the AUTO position. Check program - place the OUTPUT Selector in the OUTPUT 1 or OUTPUT 2 mode and press the ENTER button to review all twenty Be sure power is applied to the line terminals in order to power the load. Note that the output contacts are isolated from the timer power(terminals 1 and 2). This allows the timer to switch various loads from 24 volts through 277 volts.

#### **LIMITED ONE YEAR WARRANTY**

If within one (1) year from date of purchase, this product fails due to a defect in material or workmanship, Intermatic Incorporated will repair or replace, at its sole option, the unit free of charge. This warranty applies only to the original purchaser and is not transferable.

The warranty does not apply to: (a) damage caused by accident, abuse, mishandling, dropping, acts of God, or any negligent use; (b) units which have been subject to unauthorized repair, opened, taken apart, or otherwise modified; (c) units not used in accordance with directions; (d) damages exceeding the cost of the product. Some States do not allow a limitation of damages, so the foregoing limitation may not apply to you.

This warranty gives you specific legal rights and you may have other rights that vary from state to state.

**INTERMATIC INCORPORATED WILL NOT BE LIABLE FOR INCIDENTAL OR CONSEQUENTIAL DAMAGES.**

**THIS WARRANTY IS IN LIEU OF ALL OTHER EXPRESS OR IMPLIED WARRANTIES. ALL IMPLIED WARRANTIES, INCLUDING THE WARRANTY OF MERCHANTABILITY AND THE WARRANTY OF FITNESS FOR A PARTICULAR PURPOSE, ARE HEREBY MODIFIED TO EXIST ONLY AS CONTAINED IN THIS LIMITED WARRANTY, AND SHALL BE OF THE SAME DURATION AS THE WARRANTY PERIOD STATED ABOVE.** This warranty service is available by either (a) returning the product to the dealer from whom the unit was purchased, or (b) mailing postage prepaid to the nearest authorized service center listed. Please be sure to wrap the product securely when mailing to avoid damage. This warranty is made by: Intermatic Incorporated/After Sales Service, 7777 Winn Rd., Spring Grove, IL 60081-9698/815-675-7000 <http://www.intermatic.com>

#### **SERVICE CENTER/ SERVICE CENTRE CENTRE DE SERVICE**

INTERMATIC INCORPORATED

After Sales Service

7777 Winn Rd.,

(815) 675-7000

<http://www.intermatic.com>

**INTERMATIC INCORPORATED  
SPRING GROVE, ILLINOIS 60081-9698**