

# EVEREST EFI **PROCHEM**®

Operating Instructions (ENG)

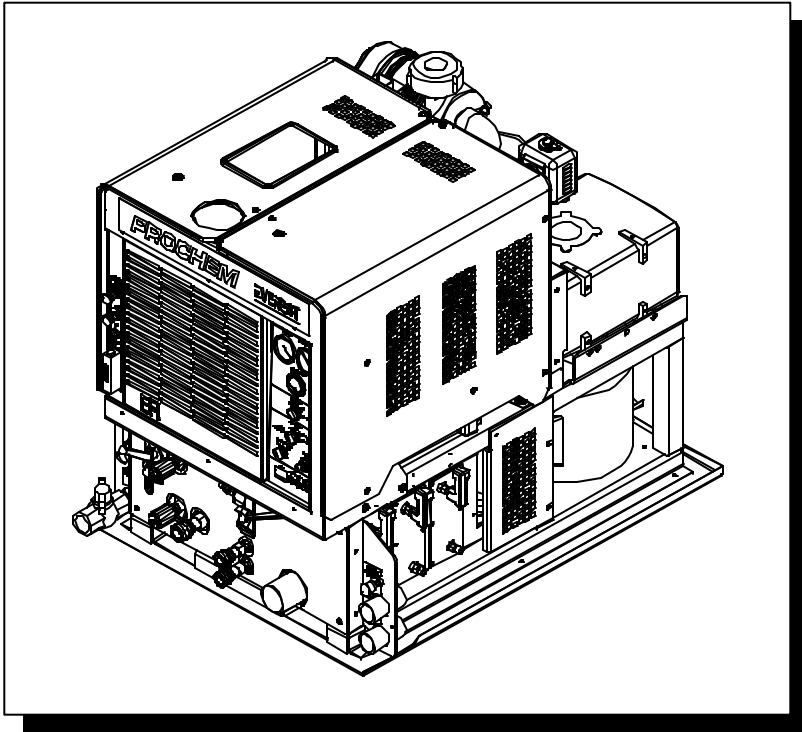

MODELS: **EVEREST EFI LP CTK**  
**EVEREST EFI HP CTK**

---

***Read instructions before operating the machine.***



980212  
01/26/05

<b>MODEL</b> _____
<b>DATE OF PURCHASE</b> _____
<b>SERIAL NUMBER</b> _____
<b>SALES REPRESENTATIVE #</b> _____

<b>YOUR DEALER</b>
<b>NAME:</b> _____
<b>ADDRESS:</b> _____
<b>PHONE NUMBER:</b> _____

**Welcome...**and congratulations on the purchase of your Mobile Cleaning Unit. This instruction manual is a guide for operating and servicing your unit. **Read this manual completely before installing or operating this unit.** This unit offers you personal convenience. All of your instrumentation and controls have been positioned to give you easy access for operation and daily maintenance.

Proper operation and service are essential to the efficient functioning of this unit. When maintained correctly, this unit will have a long, trouble-free life.

The service methods described in this manual are explained in such a manner that servicing may be performed accurately and safely. Proper service varies with the choice of procedure, the skill of the mechanic, and the tools or parts available. Before attempting any repair, make certain that you are thoroughly familiar with this equipment and are equipped with the proper tools. Any questions pertaining to operating or servicing this unit should be directed to your nearest dealer.

***THIS UNIT MUST BE INSTALLED BY THE DEALER FROM WHOM YOU PURCHASED IT IN ACCORDANCE WITH THE PRESCRIBED INSTALLATION PROCEDURES.***

MAKE CERTAIN THAT THE WARRANTY CARD IS FILLED OUT AT THE TIME OF INSTALLATION AND IS RETURNED TO YOUR DEALER.

PROFESSIONAL CHEMICALS CORPORATION  
325 SOUTH PRICE ROAD  
CHANDLER, ARIZONA 85224

Information in this document is subject to change without notice and does not represent a commitment on the part of Professional Chemicals Corporation.

# TABLE OF CONTENTS

Machine Data Log/Overview .....	1
Table of Contents .....	2
Receiving Your Unit .....	4

## HOW TO USE THIS MANUAL

How to use this Manual. ....	1-1
------------------------------	-----

## SAFETY

Safety Instructions .....	2-1
Hazard Intensity Level .....	2-3

## OPERATION & SYSTEMS

Technical Specifications .....	3-1
Installation Requirements .....	3-2
Fuel Requirements .....	3-2
Engine Oil Requirements .....	3-2
Electronic Fuel Injection System .....	3-3
Emission Control Information .....	3-3
Date Stamp Location .....	3-4
Fuel Pump and Filter .....	3-4
Error Codes .....	3-5
Zenith Distributor Locations .....	3-6
Chemicals & Water .....	3-7
Components .....	3-8
Water Pumping and Heat Transfer .....	3-12
Chemical Injection System .....	3-15
Vacuum System .....	3-16
Pre-run Inspections .....	3-17
Priming the Chemical Pump .....	3-18
Waste Pump .....	3-18
Cleaning .....	3-18
Upholstery Cleaning .....	3-19
Shutdown and Daily Maintenance (LP) .....	3-19
High Pressure System .....	3-19
High Pressure Shutdown & Return to Low Pressure .....	3-20
De-flooding Operations .....	3-20
Freezing Protection .....	3-20
Winterizing Your Unit .....	3-21
Removing Anti-freeze from Unit .....	3-22

## MAINTENANCE & SERVICE

### Maintenance

Maintenance Schedule .....	4-1
Key Maintenance Checkpoints .....	4-3
Engine .....	4-4
Vacuum Pump .....	4-5
Water Pump .....	4-6
Vacuum Inlet Filter .....	4-6
Vacuum Relief Valve .....	4-6
Vacuum Drive Belts, Pulleys And Hubs ..	4-6
Water Pump Drive Belt .....	4-7
Float Valve (Water Box) .....	4-7
Waste Tank Strainer Basket .....	4-7
Y-Strainer (Outlet) .....	4-7
Temperature Balance Orifice .....	4-7
Check Valve (Outlet) .....	4-7
Chemical Pump .....	4-7
Nitrogen Accumulator .....	4-8
Pressure Regulator .....	4-8
Vacuum Hoses .....	4-8
Pressure Hoses .....	4-8
Optional Waste Pump-out .....	4-8
Chemical and Simulator Valve .....	4-8
Engine Coolant Replacement .....	4-8
General Service Adjustments	
Check Valve (Solution Outlet) .....	4-9
Chemical Pump .....	4-9
Packing Nut Adjustment (Chemical Metering & Selector Valves) ..	4-10
Pressure Regulator .....	4-10
Troubleshooting .....	4-11

**PARTS LIST**

*Framework* ..... 5-1  
*Side Panel, Right* ..... 5-5  
*Side Panel, Left*..... 5-7  
*Chemical Panel*..... 5-9  
*Control Panel* ..... 5-11  
*Engine* ..... 5-13  
*Engine Coolant*..... 5-19  
*Vacuum Blower*..... 5-21  
*Water Pump-PP*..... 5-23  
*Water Pump-PPHP*..... 5-25  
*Vacuum/Heat Exchanger And Silencer* ..... 5-29  
*Solution Temperature Control Valve* ..... 5-31  
*Heli-Coil Heat Exchanger* ..... 5-33  
*Solution Outlet*..... 5-35  
*Water Box -PP* ..... 5-37  
*Water Box -PPHP* ..... 5-39  
*Pressure Regulator-PP*..... 5-41  
*Pressure Regulator-PPHP*..... 5-43  
*Waste Tank*..... 5-45  
*Hose Accessories* ..... 5-47  
*Battery-Floor Mount*..... 5-49  
*Automatic Pumpout (Optional)* ..... 5-51  
*Wand- Titanium Six Jet (Optional)*..... 5-55  
*Wand - Quad-Jet (Optional)*..... 5-57  
*Wand – Tri-Jet (Optional)* ..... 5-59  
*Stair Tool (Optional)*..... 5-61  
*Upholstery Tool (Optional)*..... 5-63  
*Shelf Assembly (Optional)* ..... 5-65  
*Water Tank, Dual With Demand Pump (Optional)*..... 5-67  
*Water Tank-Demand Pump (Optional)*..... 5-69  
*Hose Reel (Optional)* ..... 5-71  
*Wiring Diagram* ..... 5-73  
*Hose Diagram-PP*..... 5-74  
*Hose Diagram-PPHP*..... 5-75  
*Warranty*..... 5-76

## RECEIVING YOUR UNIT

### ACCEPTANCE OF SHIPMENT

Every part of your cleaning unit was carefully checked, tested, and inspected before it left our manufacturing plant. **Upon receiving the unit, make the following acceptance check:**

1. The unit should not show any outward signs of damage. If damaged, notify the delivering carrier immediately.
2. Check your equipment and packing list. The cleaning unit should arrive equipped with the following items (unless otherwise specified).

***NOTE: Your distributor from whom you purchased this mobile cleaning unit is responsible for the correct installation of this machine. The dealer is also responsible for initial training of your operators and maintenance personnel in the proper operation and maintenance of this unit.***

### EQUIPMENT LIST:

1. Console.
2. Waste tank
3. Hose clamps for vacuum hoses.
4. 150 ft. of 2" vacuum hose.
5. 2 vacuum hose connectors.
6. 150 ft. of 1/4" high pressure hose with quick connects.
7. 50 ft. water supply hose with quick connect.
8. Installation bolting kit.
9. Installation mounting plates.
10. Operation and service manual for engine, water pump, and vacuum pump manuals.
11. Fuel Pump Assembly and Power Cord.

## HOW TO USE THIS MANUAL

This manual contains the following sections:

- HOW TO USE THIS MANUAL
- SAFETY
- INSTALLATION REQUIREMENTS
- SYSTEMS
- OPERATIONS
- MAINTENANCE & SERVICE
- PARTS LIST

The HOW TO USE THIS MANUAL section will tell you how to find important information for ordering correct repair parts.

Parts may be ordered from authorized dealers. When placing an order for parts, the machine model and machine serial number are important. Refer to the MACHINE DATA box which is filled out during the installation of your machine. The MACHINE DATA box is located on the inside of the front cover of this manual.

MODEL _____
DATE OF PURCHASE _____
SERIAL NUMBER _____
SALES REPRESENTATIVE # _____

The model and serial number of your machine is on the side approximately where shown.

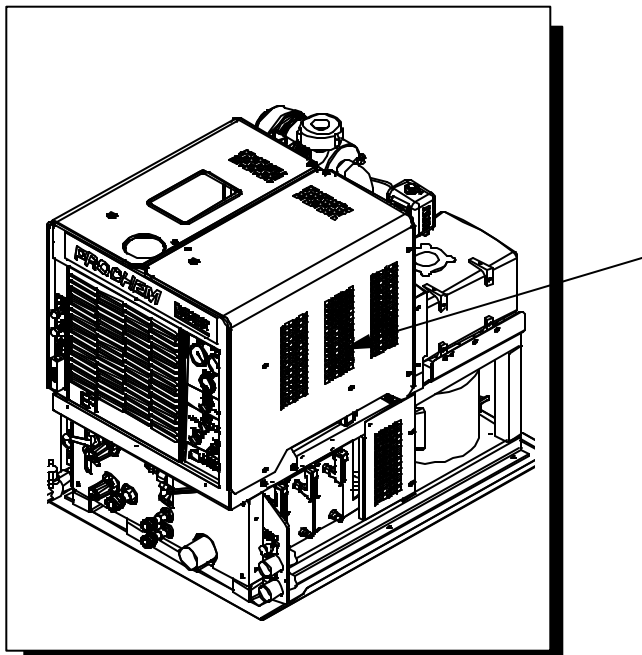

The SAFETY section contains important information regarding hazard or unsafe practices of the machine. Levels of hazards is identified that could result in product or personal injury, or severe injury resulting in death.

The OPERATIONS section is to familiarize the operator with the operation and function of the machine.

The MAINTENANCE section contains preventive maintenance to keep the machine and its components in good working condition. They are listed in this general order:

- Engine
- Vacuum Pump
- Water Pump
- Drive Belts, Pulleys & Hubs
- Chemical Pumps
- Hoses
- Vac/Exhaust Heat Exchanger
- General Service Adjustments
- Troubleshooting

The PARTS LIST section contains assembled parts illustrations and corresponding parts list. The parts lists include a number of columns of information:

- **REF** – column refers to the reference number on the parts illustration.
- **PART NO.** – column lists the part number for the part.
- **DESCRIPTION** – column is a brief description of the part.
- **SERIAL NO. FROM** – column indicates the first machine the part number is applicable to. When the machine design has changed, this column will indicate serial number of applicable machine. The main illustration shows the most current design of the machine. The boxed illustrations show older designs. If column has an asterisk (\*), call manufacturer for serial number.
- **NOTES** – column for information not noted by the other columns.

**NOTE:** If a service or option kit is installed on your machine, be sure to keep the **KIT INSTRUCTIONS** which came with the kit. It contains replacement parts numbers needed for ordering future parts.

**NOTE:** The 98# on the lower left corner of the front cover is the part number for this manual.

# IMPORTANT SAFETY INSTRUCTIONS

When using this machine, basic precautions must always be followed, including the following:

## READ ALL INSTRUCTIONS BEFORE USING THIS MACHINE.

### **WARNING:**

These symbols mean **WARNING** or **CAUTION**. Failure to follow warnings and cautions could result in fatality, personal injury to yourself and/or others, or property damage. Follow these instructions carefully!

### **CAUTION:**

**Read the operator's manual before installing or starting this unit.** Failure to adhere to instructions could result in severe personal injury or could be fatal.

**Operate this unit and equipment only in a well-ventilated area.** Exhaust fumes contain carbon monoxide which is an odorless and deadly poison that can cause severe injury or fatality. **DO NOT** run this unit in an enclosed area. **DO NOT** operate this unit where the exhaust may enter any building doorway, window, vent, or opening of any type.

**Gasoline is extremely flammable and its vapors can explode if ignited.** Store gasoline only in approved containers, in well-ventilated, unoccupied buildings away from sparks or flames. Never carry any gasoline or flammable material in the vehicle. Fumes may accumulate inside the vehicle and ignite, causing an explosion.

**DO NOT** store any type of flammable material in the vehicle.

**This unit must be operated with the vehicle or trailer doors open in order to ensure adequate engine ventilation.**

**DO NOT operate engine if gasoline is spilled.** Avoid creating any ignition source until the gasoline has been cleaned up. Never use gasoline as a cleaning agent.

**DO NOT place hands, feet, hair, or clothing near rotating or moving parts.** Avoid any contact with moving parts! Rotating machinery can cause injury or fatality.

**Never operate this unit without belt guards or heat guards.** The high speed moving parts, such as belts and pulleys, should be avoided while this unit is running. Severe injury, damage, or fatality may result.

**DO NOT service this unit while it is running.** The high-speed mechanical parts as well as high temperature components may result in severe injury or severed limbs.

**Never touch electrical wires or components while the engine is running.** They can be sources of electrical shock.

**Engine components can get extremely hot from operation.** To prevent severe burns, **DO NOT** touch these areas while the engine is running - or immediately after the engine is turned off.

**DO NOT touch the exhaust system while this unit is running.** Severe burns may result.

**Before servicing this unit, allow it to "cool down."** This will prevent burns from occurring.

**Water under high pressure at high temperature can cause burns, severe personal injury, or fatality.** Shut down machine, allow to cool down, and relieve system of all pressure before removing valves, caps, plugs, fittings, filters, and bolts.

**DO NOT leave the vehicle engine running while operating this unit.**

**Dangerous Acid, Explosive Gases!** Batteries contain sulfuric acid. To prevent acid burns, avoid contact with skin, eyes and clothing. Batteries produce explosive hydrogen gas while being charged. To prevent a fire or explosion, charge batteries only in well ventilated areas. Keep sparks, open flames, and other sources of ignition away from the battery at all times. Keep batteries out of the reach of children. Remove all jewelry when servicing batteries.

Before disconnecting the negative (-) ground cable, make sure all switches are OFF. If ON, a spark will occur at the ground cable terminal which could cause an explosion if hydrogen gas or gasoline vapors are present. When disconnecting the battery, **ALWAYS** disconnect the negative (-) terminal **FIRST**.

**DO NOT smoke around the unit.** Gas fumes may accumulate and be ignited. The battery is also extremely flammable. This will prevent possible explosions.

**DO NOT damage the vehicle in any manner during installation.** When routing fuel lines **DO NOT** place the hose in any location where damage may occur to the hose or vehicle. Avoid any contact with moving parts, areas of high temperature, brake lines, fuel lines, muffler, catalytic converter, or sharp objects.

**DO NOT cut or splice any of the vehicle fuel lines during fuel line installation.** This may result in fuel leaks and potentially dangerous conditions. There is no fuel solenoid shut off on this unit. Use only the provided fuel hose for fuel lines. When traversing the vehicle floor with fuel lines, always use a bulkhead adapter. This will prevent leakage and ensure that the hose is not punctured by vehicle vibration abrasion.

**DO NOT exceed your vehicle's weight limit.** The console with waste tank and accessories weighs approximately 1840 lbs. Make certain to account for any additional accessories in your weight and balance calculations. Make certain that the vehicle has the correct axle rating. This will prevent unsafe vehicle driving conditions.

**We require high-back seats on all vehicles in which units are to be installed for head and neck protection.** We recommend using a metal partition between the seats and equipment.

**DO NOT operate this unit without the water supply attached and turned on.** The water pump and other vital components may be seriously damaged if this unit is permitted to operate dry without water.

**DO NOT operate this unit without the filter installed in the waste tank.**

**Keep your vehicle work area clean.** Wands, stair tools, and other accessories must be securely fastened before driving the vehicle.

**All pressure hoses must be rated for 3000 PSI at 250°F.** Thermoplastic hoses do not meet these specifications and should not be used. Severe burns and injury may result if the hoses do not meet these requirements.

**The winterizing loop hose assembly, Part #10-805380, is for winterizing use only.** If used improperly, live steam may escape from this hose, causing it to whip around. Burns or injury may result.

**Make certain that you receive complete training by the distributor from whom you purchased this unit.**

**This unit uses high pressure and temperature. Improper or irresponsible use may result in serious injury.**

**Do not modify this unit in any manner.** Improper modification can cause severe personal injury or fatality.

**CALIFORNIA PROPOSITION 65 WARNING:** Engine exhaust from this product contains chemicals known to the State of California to cause cancer, birth defects, or other reproductive harm.



# HAZARD INTENSITY LEVEL

The following **WARNING LABELS** are found on your cleaning unit . These labels point out important **Warnings** and **Cautions** which should be followed at **all** times. Failure to follow warnings and cautions could result in fatality, personal injury to yourself and/or others, or property damage. Follow these instructions carefully! **DO NOT** remove these labels.

**NOTE:** If at any time the labels become illegible, promptly replace them.

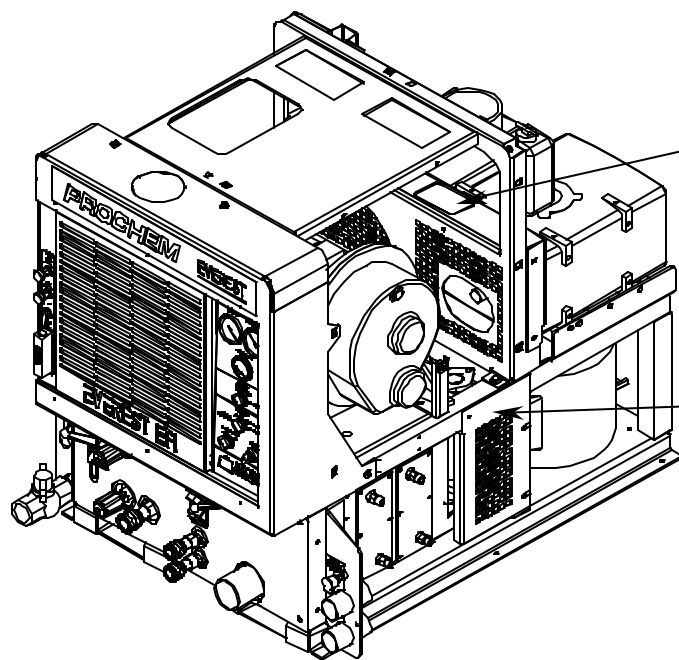
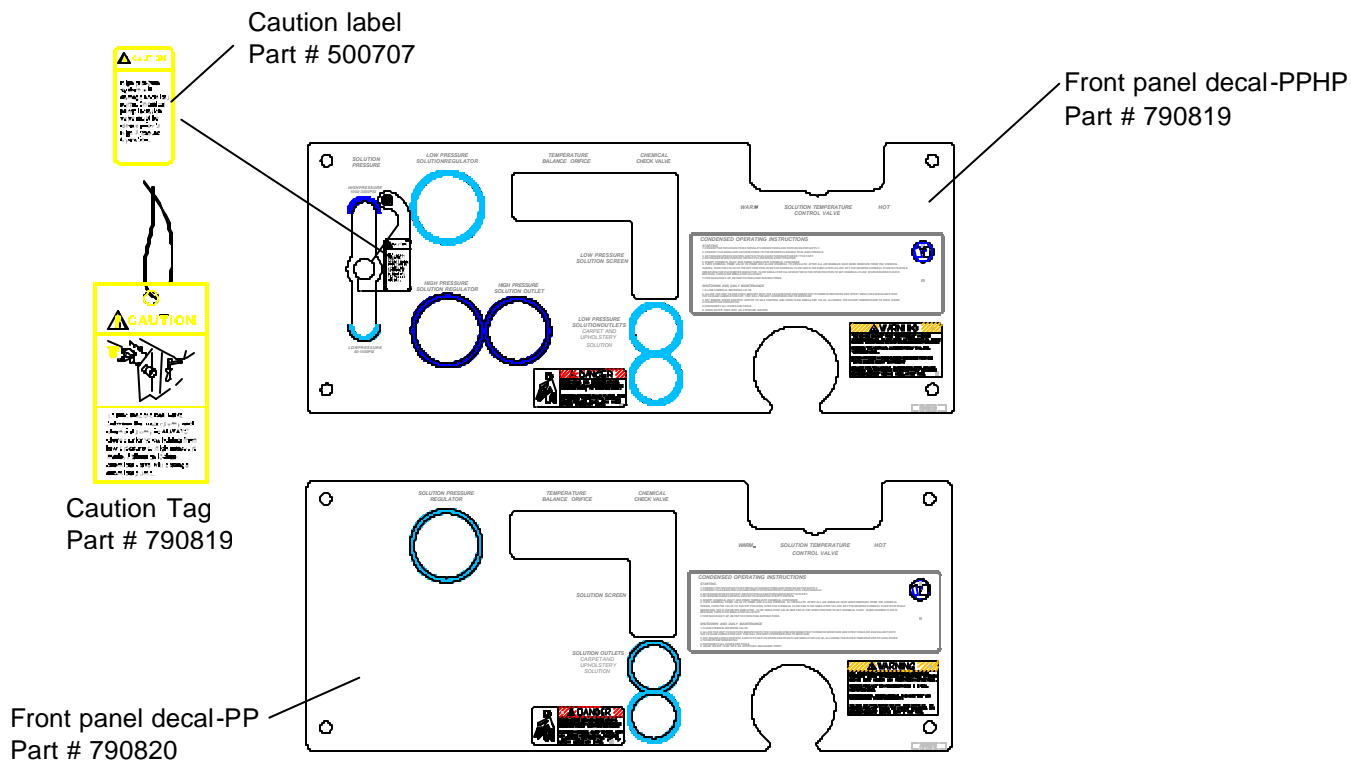

Warning label  
Part # 500769



Caution label  
Part # 500770

**TECHNICAL SPECIFICATIONS**

ITEM	DIMENSION/CAPACITY	
Engine speed	2200 rpm (medium speed) Water Pump ON 900 rpm (idle speed) Water Pump OFF.	
Water pump rpm	1455 rpm	
Vacuum pump rpm	3400 rpm	
Water flow rate	4.5 GPM (maximum)	
Water pump pressure (low pressure)	1000 PSI (maximum)	
Water pump pressure (high pressure)	3000 PSI (maximum)	
Vacuum relief valve	13" Hg	
Waste tank capacity	80 or 100 gallons	
Console weight	860 lbs.	
Console weight (with waste tank & waste tank accessories)	1110 lbs (1840 lbs. If waste tank is full)	
<b>TORQUE VALUES</b>		
Engine hub	480 inch lbs	40 foot/lbs
Vacuum pump hub	192 inch/lbs	16 foot/lbs
Water pump shaft bolt	300 in//lbs	25 foot/lbs

**JET SIZING:**

Recommended **floor tool** tip sizing not exceed a total of “.06”. Using larger jet sizes on your cleaning unit may reduce cleaning temperatures.

Example: Tri-jet wand uses three 9502 jets (95° spray angle w/ .02 orifice).  
 $.02 \times 3 = .06$

When using two floor tools while cleaning with this unit, it is recommended that each tool tip size does not exceed a total of “.045”.

Example: Tri-jet wand uses three 95015 jets (95° spray angle w/ .015 orifice).  
 $.015 \times 3 = .045$ ..... $.06 \times 2 \text{ tools} = .12$

Upholstery tool jet size: 80015  
 Stair tool jet size: 9502



## ELECTRONIC FUEL INJECTION SYSTEM

This unit is equipped with the latest Zenith electronic fuel injection (EFI) technology. The EFI technology provides more effective fuel distribution and improved power management through the use of an electronic “brain” called the electronic control unit (ECU). The ECU also provides improved engine emissions through more effective combustion of the fuel/air mixture. The fuel system, engine set up, and exhaust system are systems approved by the Environmental Protection Agency (EPA). Any alteration or modification to the system must receive approval from the EPA.

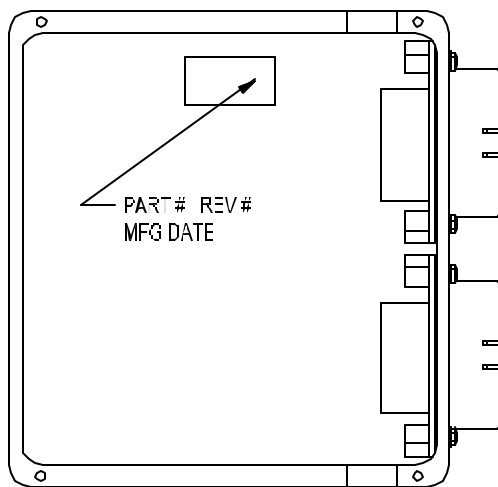

## EMISSION CONTROL INFORMATION

The Zenith Power Products (ZPP) Emission control label is located on the valve head cover of the engine near the oil fill cap.

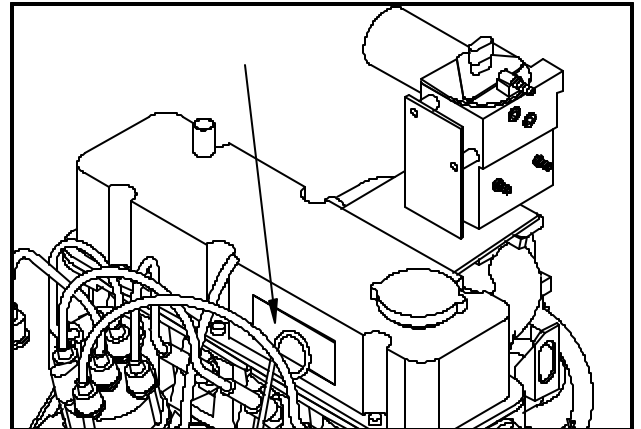

## OPERATIONS

### DATE STAMP LOCATION

When referring to an engine for assistance from your dealer, ProChem, or ZPP please identify your engine by the serial # and date code stamped on the machined surface next to the oil dipstick.

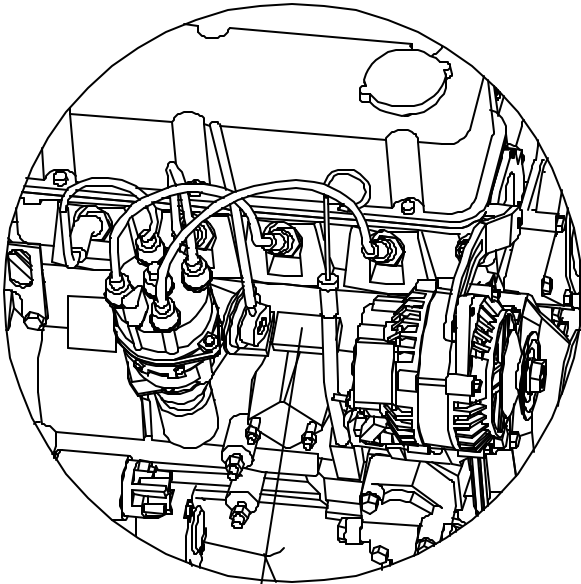

SERIAL NUMBER

### FUEL PUMP AND FILTER

Your Everest EFI console was shipped to the dealer with a specific fuel pump and fuel filter. Ensure that **ONLY** these items are used in the installation of your unit. The EFI system is much more sensitive to unwanted material in the fuel stream. Contamination of the fuel stream may clog the injectors and adversely affect performance. Please be sure to adhere to the filter maintenance schedule located in the Operations Section of this manual.

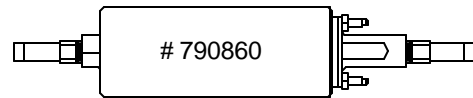

FUEL PUMP

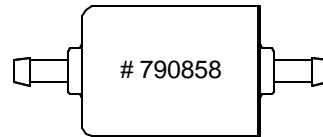

FUEL FILTER

## ERROR CODES

On rare occasions the engine may experience abnormal operation conditions and shut down. Upon shutdown the amber light in the upper right corner of the instrument panel will repeatedly flash an error code to help you determine the root cause of the shutdown. Double-digit numbers are flashed one digit at a time, (i.e. "12" would be shown as "Flash", pause, "Flash", "Flash"). The codes are listed below for your convenience.

	CONDITION	SEQUENCE	RESULT	TROUBLE CODE	TROUBLE FLAG	CODE/FLAG RETAINED IN MEMORY WITH KEY OFF?
1	ENGINE OIL PRESSURE SWITCH INDICATES LOW OIL PRESSURE		OIL PRESSURE SWITCH INDICATES OIL PRESSURE IS LOW FOR 1 COMPLETE SECOND - ENGINE		2	NO
2	ENGINE OVERHEATING DETECTED (COOLANT >= 239 F)	1	RPM LIMITED TO 950 MAXIMUM FOR 60 SECONDS		3	NO
		2	ONCE 60 SECOND TIME LIMIT IS EXCEEDED - ENGINE SHUTDOWN OCCURS		3	NO
3	TRANSMISSION OIL TEMPERATURE SWITCH INDICATES OVERTEMP	1	RPM LIMITED TO 950 MAXIMUM FOR 60 SECONDS		4	NO
		2	ONCE 60 SECOND TIME LIMIT IS EXCEEDED - ENGINE SHUTDOWN OCCURS		4	NO
4	BEGINNING OF DIAGNOSTIC ROUTINE		NO FAULT CONDITION EXISTS - SIGNIFIES BEGINNING OF FLASH CODES	12		YES-ALWAYS PRESENT
5	ENGINE COOLANT SENSOR INDICATES SHORT CIRCUIT OR EXTREME OVERHEATING OF ENGINE (COOLANT TEMP >= 266 F)	1	TROUBLE CODE IS STORED IN MEMORY	14	3	CODE RETAINED IN MEMORY
		2	RPM LIMITED TO 950 MAXIMUM FOR 60 SECONDS	14	3	FLAG CLEARS WHEN IGNITION IS OFF
		3	ONCE 60 SECOND TIME LIMIT IS EXCEEDED - ENGINE SHUTDOWN OCCURS	14	3	FLAG CLEARS WHEN IGNITION IS OFF
6	ENGINE COOLANT SENSOR INDICATES OPEN CIRCUIT		TROUBLE CODE IS STORED IN MEMORY	15		CODE RETAINED IN MEMORY
7	PEDAL POSITION SENSOR OVER VOLTAGE (OVER 4.5 VOLTS)		TROUBLE CODE IS STORED IN MEMORY	21		CODE RETAINED IN MEMORY
8	PEDAL POSITION SENSOR UNDER VOLTAGE (0 VOLTS)		TROUBLE CODE IS STORED IN MEMORY	22		CODE RETAINED IN MEMORY
9	AIR TEMPERATURE SENSOR INDICATES OPEN CIRCUIT		TROUBLE CODE IS STORED IN MEMORY	23		CODE RETAINED IN MEMORY
10	AIR TEMPERATURE SENSOR INDICATES SHORT CIRCUIT		TROUBLE CODE IS STORED IN MEMORY	24		CODE RETAINED IN MEMORY
11	MAP SENSOR CIRCUIT INDICATES HIGH VOLTAGE (4.98)		TROUBLE CODE IS STORED IN MEMORY	33		CODE RETAINED IN MEMORY
12	MAP SENSOR CIRCUIT INDICATES SHORT TO GROUND		TROUBLE CODE IS STORED IN MEMORY	34		CODE RETAINED IN MEMORY
13	OXYGEN SENSOR - LEAN CONDITION DETECTED		TROUBLE CODE IS STORED IN MEMORY	44		CODE RETAINED IN MEMORY
14	OXYGEN SENSOR - RICH CONDITION DETECTED		TROUBLE CODE IS STORED IN MEMORY	45		CODE RETAINED IN MEMORY

# OPERATIONS

## ZENITH DISTRIBUTOR LOCATIONS

- **ITAL ENGINE COMPANY (09046)**  
97 CYPRESS ST. SW  
REYNOLDSBURG, OHIO 43068
- **CULLUM & BROWN, INC. (09045)**  
1607 WABASH  
WICHITA, KS 67214
- **DIESEL ELECTRIC SERVICE & SUPPLY (09116)**  
652 W. 1700 SOUTH  
SALT LAKE CITY, UT 84104
- **POWER EQUIPMENT COMPANY (09117)**  
15225 INDUSTRIAL RD.  
OMAHA, NE 68144
- **ENGINE WORKS, INC. (09178)**  
1345 PARAMOUNT PKWY.  
BATAVIA, IL 60510
- **FRONTIER EQUIPMENT, LTD. (09185)**  
8029 RIVER WAY  
DELTA, BC CANADA V4G IL3
- **GULF ENGINE & EQUIPMENT (09229)**  
2306 ENGINEERS RD.  
BELLE CHASSE, LA 70037
- **HAMILTON ENGINE SALES, INC. (09287)**  
5540 N. E. COLUMBIA BLVD.  
PORTLAND, OR 97218
- **H. G. MAKELIM COMPANY (09480)**  
219 SHAW RD.  
SOUTH SAN FRANCISCO, CA 94080
- **LOFTIN EQUIPMENT COMPANY, INC. (09490)**  
12TH NORTH 45TH AVE.  
PHOENIX, AZ 85043
- **M.G. BRYAN EQUIPMENT COMPANY (09503)**  
4834 READING ST.  
DALLAS, TX 75247
- **NORPRO ISUZU ENGINES, INC. (09505)**  
385 TOWN ST.  
HADDAM, CT 06423
- **SOUTHEAST SERVICE & SUPPLY (09698)**  
1721-E OAKBROOK DR.  
NORCROSS, GA 30093
- **TOTAL POWER LTD**  
6670 EXCEISIOR COURT  
MISSISSAUGA, ON CANADA L5T 2J2
- OH, IN, KY, WV**  
**PA (WESTERN)**  
PHONE: 740/964-0089
- KS, MO**  
PHONE: 316/262-5156  
800/362-3222
- UT**  
PHONE: 801/972-1836
- NE, IA**  
PHONE: 402/330-5100
- IL**  
PHONE: 630/879-7977  
800-832-7217
- BC, AB**  
PHONE: 604/946-5531
- LA, MS**  
PHONE: 504/393-1701
- WA, OR, AK**  
PHONE: 503/288-6714  
800/437-3644
- CA**  
PHONE: 650/873-4757
- AZ**  
PHONE: 602/272-9466
- TX, OK**  
PHONE: 214/631-9787
- CT, MA, VT, NH, ME, RI**  
PHONE: 860/873-0100
- GA**  
PHONE: 770/448-4251  
800/241-4595
- ON**  
PHONE: 905/670-1535

## CHEMICAL REQUIREMENTS

This cleaning unit, due to its chemical injection pump design, can be used with a variety of water-diluted chemical compounds (either acidic or alkaline), depending on the job to be done. However, to obtain optimum results with this unit, we recommend using the PROCHEM line of chemicals. For information on using the cleaning compounds, refer to the PROCHEM chemical manual.

## WATER REQUIREMENTS

Hard water deposits will adversely affect the plumbing and heat exchange systems on this unit. The map below will give you an idea of where areas of high water hardness may occur. However, any water supply obtained from a well is almost always hard water and a water softener will be needed to protect your equipment.

**NOTE: Equipment malfunction or component failure caused by hard water scaling is NOT covered under the warranty.**

If you are operating this unit in an area where the unit will be using water in which the hardness exceeds

3-1/2 grains, we highly recommend a suitable water softener be installed. If using a water softener, it must have a five (5) GPM (or greater) flow capacity without any hose constrictions.

Using a water softener will reduce maintenance and decrease down time caused by hard water scaling. It will also allow cleaning chemicals to be more effective in lower concentrations.

If you require a water softener, PROCHEM has a model to meet your needs. Please contact your nearest distributor for information, price, and availability.





# COMPONENTS

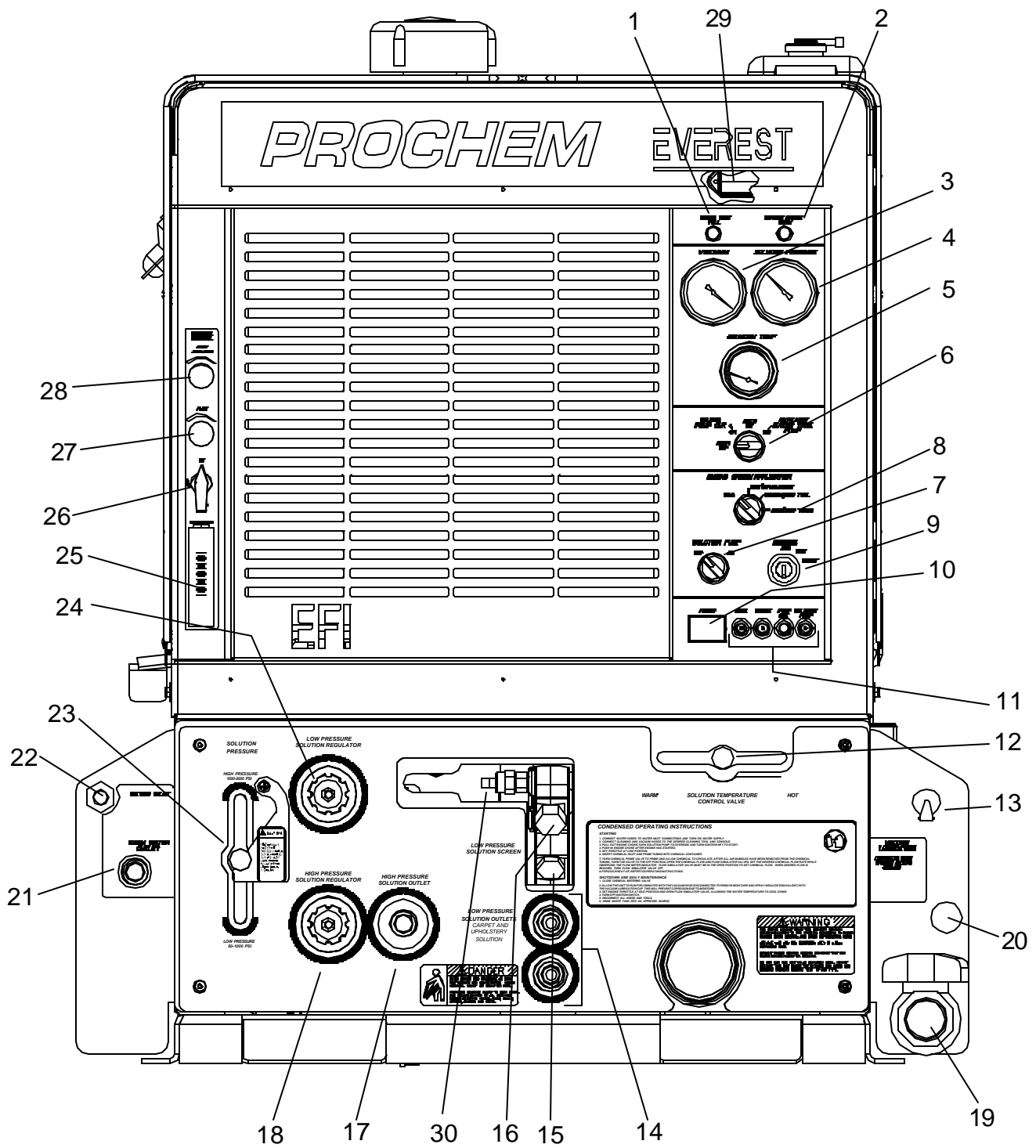

## 1. WASTE TANK FULL INDICATOR LIGHT

This indicator light is activated when the waste tank is full. When lit the unit will shutdown protecting the equipment from damage. This also indicates that the waste tank must be emptied before the unit can be brought back in service.

**NOTE: Never dispose of waste water in storm drains, water ways or on ground areas. Always dispose of waste in accordance with local state and federal laws.**

## 2. SERVICE ENGINE SOON

This light, when flashing, signals a problem with the unit. When this occurs, troubleshooting is required.

## 3. VACUUM GAUGE

This gauge indicates in inches of mercury how much vacuum the system is producing at any given time.

## 4. SOLUTION PRESSURE GAUGE

This gauge registers the amount of pressure in the system.

## 5. SOLUTION TEMPERATURE GAUGE

This gauge measures the temperature of the cleaning solution as it exits the machine.

## 6. WASTE PUMPOUT AND AUXILIARY WATER PUMP SWITCH

This four-position switch is for activating the waste pumpout device. It also serves to activate the fresh water transfer pump. For turning on pumps, rotate clockwise. For turning off pumps, rotate counter clockwise.

## 7. SOLUTION PUMP SWITCH

This switch serves to energize the magnetic clutch to turn the water pump on or off. Turn clockwise for activating the pump and counter clockwise for deactivating the pump.

## 8. ENGINE SPEED CONTROL

This serves to set the engine speed and operating parameters. The 'Low', 'Medium' and 'High' settings are set for upholstery cleaning, single wand cleaning, and dual wand cleaning respectively.

## 9. KEY SWITCH

The key switch controls the power for the machine. To turn the machine on, rotate the key clockwise until the starter engages the engine. When machine is running let off the switch and engine will continue to run. To turn power off, rotate key counter clockwise to stop position, engine will then stop.

## 10. HOUR METER

The hour meter records the number of hours the unit has run. This serves as a time recorder for servicing the machine.

## 11. CIRCUIT BREAKERS

These serve to protect the circuits from electrical spike and over loads and protects wires from damage and fire.

## 12. SOLUTION TEMPERATURE CONTROL VALVE

This valve enables additional heat exchangers to contribute more heat to the system if necessary. By moving the lever to the right it adds more heat, by moving to the left it removes heat.

## 13. OIL CUP

The oil cup allows lubricant spray to reach the vacuum blower.

## 14. SOLUTION OUTLETS

The solution outlets are the connecting point for the high pressure cleaning hoses. These outlets are quick disconnects that allow hoses to be plugged into the unit.

# COMPONENTS

## 15. SOLUTION SCREEN

The solution screen is located on the front of the machine. The function of this screen is to trap foreign particles from exiting the machine and plugging the orifices of the cleaning tools. This screen is part of the machine maintenance cleaning.

## 16. CHEMICAL CHECK VALVE

The chemical check valve allows chemicals to enter the system and travel in a singular direction to the wand. The chemical check valve prevents chemicals from traveling up-stream into the solution system of the unit.

## 17. HIGH PRESSURE SOLUTION OUTLET

The high pressure solution outlet is the connecting point for the high pressure hose. This outlet is a quick disconnect that allows pressure washing hoses to be plugged into the unit. (HP unit only)

## 18. HIGH PRESSURE REGULATOR

The regulating valve controls the amount of pressure in the pressure washing circuit. By turning the handle clockwise, it has the effect of increasing the pressure. Turning it clockwise has the effect of lowering the pressure. (HP unit only)

## 19. WASTE OUTLET

This valve allows the waste tank to be emptied. Turning clockwise opens the valve.

**NOTE: This valve must be closed during operation.**

## 20. WASTE PUMPOUT

This auxiliary pump serves to empty the waste collection tank automatically. A float located inside the tank automatically turns off and on when the solution level reaches certain points.

## 21. WARM WATER OUTLET

The warm water outlet allows the cleaning technician to drain hot water from the water box for mixing chemical.



**Water from this valve is hot.**

## 22. WATER INLET

This quick connect allows the water supply hose to be connected to the unit.

## 23. PRESSURE SELECTOR VALVE

This selector valve allows the technician to switch from high pressure to low pressure. By moving the handle to the up position, the high pressure circuit is activated allowing the unit to be used as a pressure washer. By positioning the valve handle to the down position, the low pressure circuit is activated allowing the unit to be used for carpet cleaning. (HP unit only)

## 24. LOW PRESSURE REGULATOR

This pressure regulating valve allows the low pressure circuit to be adjusted by turning the handle clockwise the pressure will increase, by turning counter clockwise the pressure will decrease.

## 25. FLOW METER

The flow meter is a gauge to indicate how much liquid chemical is being introduced in the water system. The quantity can be increased by turning the chemical flow knob counter clockwise.

## 26. CHEMICAL PRIME CONTROL VALVE

This valve allows the chemical to circulate through the chemical system with little or no restriction. It also purges out air that may be trapped in the lines and cavities of the chemical pump. By turning the valve clockwise the injection system is enabled.

## 27. CHEMICAL METERING VALVE

The chemical metering valve regulates the amount of chemical that is injected into the system. Clockwise rotation of the knob closes the valve. Counter clockwise rotation opens the valve, allowing more chemical to enter the system.

## 28. FLOW SIMULATOR VALVE

This valve allows solution to move through the machine and chemical to be injected simulating the cleaning process. This allows the operator to set the chemical flow level without connecting tools to the machine. It is also useful in troubleshooting. The valve is turned off by rotating the knob clockwise and opened by turning the knob counter clockwise.

## 29. PANEL LIGHT

This light is useful if the machine is used in a poorly lit area or night use. It is helpful in reading the instruments and gauges.

## 30. TEMPERATURE BALANCE ORIFICE

The temperature balance orifice helps to balance and stabilize the solution temperature within the system.

## **OPERATIONS**

### **WATER PUMPING AND HEAT TRANSFER SYSTEM**

Cold water enters the console through the water inlet. When the water box is full the valve will automatically shut off.

Water then flows from the water box, through a strainer, into the water pump where it is pumped to the pressure regulator manifold where the pressure regulator provides and maintains the desired pressure setting.

The pressure regulator manifold includes a nitrogen charged accumulator which helps reduce pressure spikes from the pump.

A certain amount of water is by-passed from the pressure regulator due to over pumping capacity of the water pump. Water that is not called for in the cleaning process is channeled through a heat exchanger box into the first heater core from the front of the unit. This bypass water may circulate several times through the bypass heat exchanger allowing the water to be pre-warmed.

The next stage of heating and water flow is to the helicoil, when water is called for in the cleaning process it flows to the helicoil under pressure. Heat from the engine coolant is exchanged to the cleaning solution through a series of spiraled copper tubing. This allows the engine coolant to travel in a counter rotating direction to the cleaning water during the exchange process creating a very efficient transfer of heat out of the engine and into the cleaning solution.

The third stage of plumbing and heat exchange takes place in the 2nd heater core located in the heater box. These hot engine/vacuum exhaust gases are forced through heater core #2 creating the third stage of heat transfer to the cleaning solution.

Finally, the hot solution passes to the outlet manifold where cleaning chemicals are injected from the chemical pulse pump. This manifold serves as a temperature sensing point and a connecting point for the high-pressure hoses. Also a check valve is located in this outlet manifold prohibiting chemicals from backing up into the system.

The cleaning solution then passes through high-pressure hoses and is distributed by the cleaning tool to a surface that is being cleaned, completing the water pumping and heating cycle of the cleaning unit.

SINGLE SYSTEM WATER FLOW DIAGRAM LOW PRESSURE (WARM)

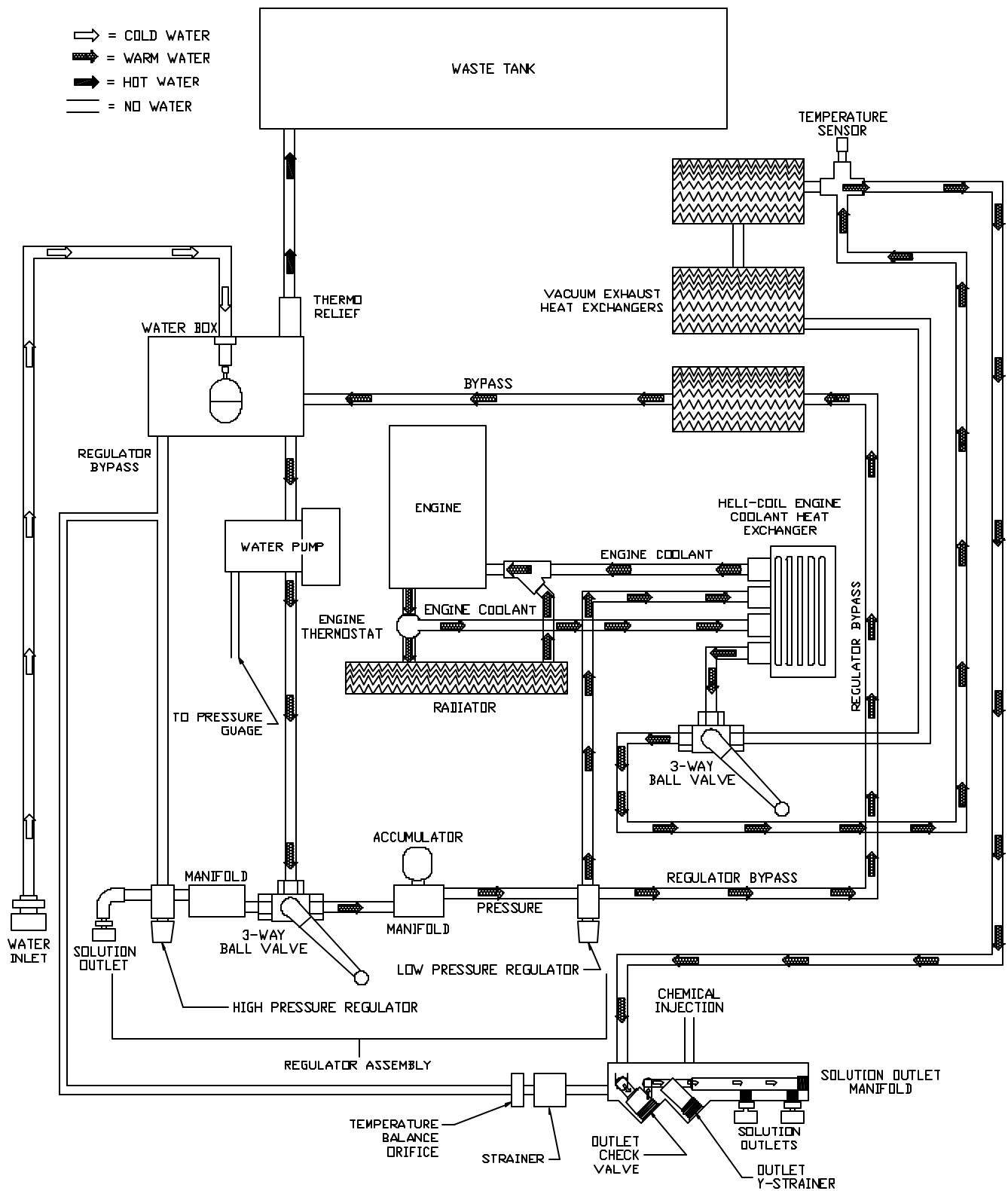

# OPERATIONS

## SINGLE SYSTEM WATER FLOW DIAGRAM LOW PRESSURE (HOT)

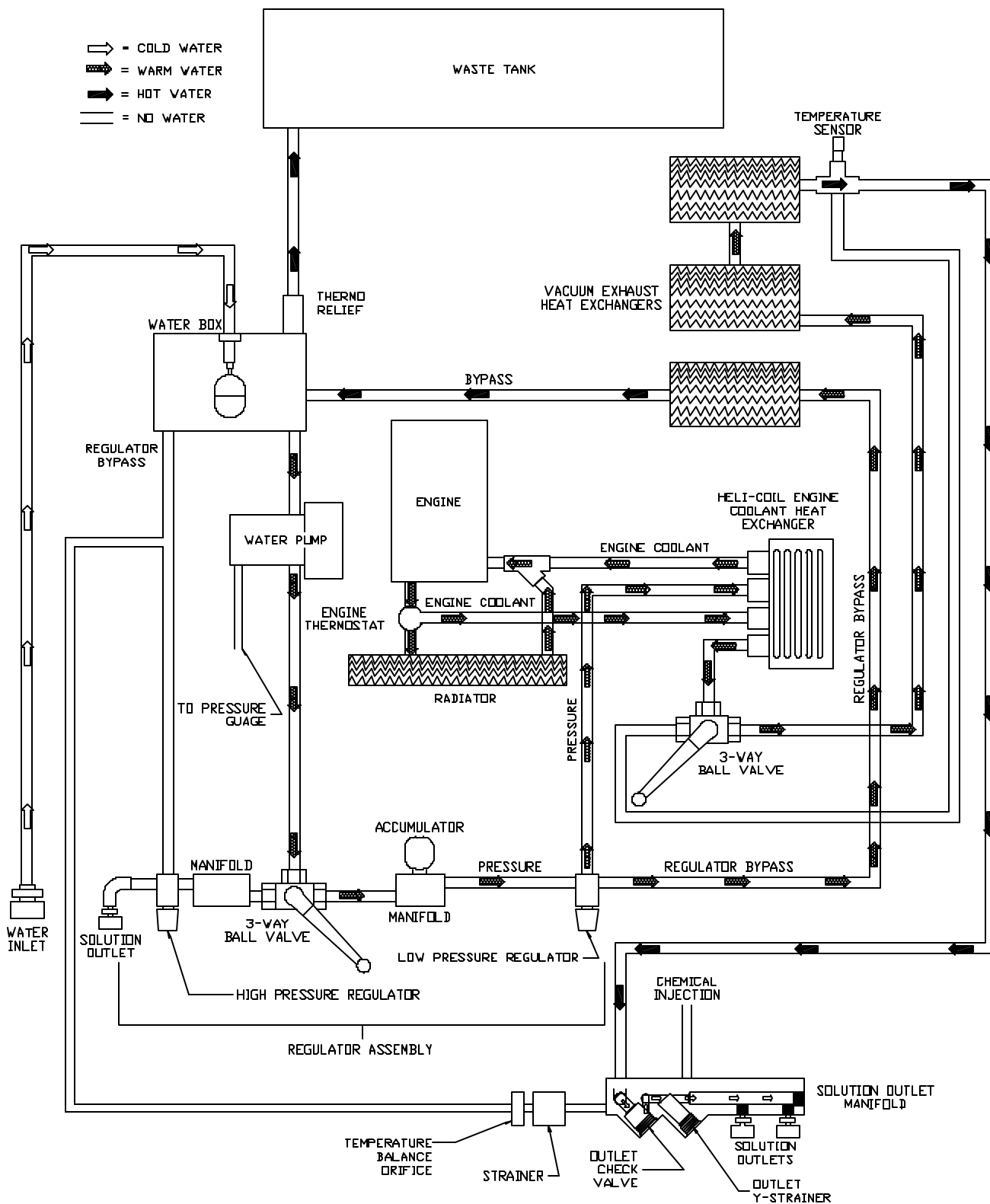

## CHEMICAL INJECTION SYSTEM

The chemical injection system is unique in that it utilizes the pressure spikes generated by the high-pressure water pump to move chemical into the main pressure stream. The high pressure spikes move the diaphragm in the chemical pulse pump forcing small amounts of liquid chemical to be moved in a single direction of flow with the aid of two check valves.

The chemical is picked up from the container and fed through the flow meter to the chemical pulse pump where it is pressurized.

After reaching the chemical pulse pump the chemicals can either go into a bypass loop to purge air from the system or the chemical can be directed by the chemical selector valve to the metering valve. The metering valve creates an orifice allowing the correct amount of chemical to enter the outlet manifold. The outlet manifold assembly is complete with a check valve that will not allow the chemicals to travel upstream into the plumbing system of the unit.

The chemicals are then mixed with hot pressurized water that make up a solution for the cleaning application.

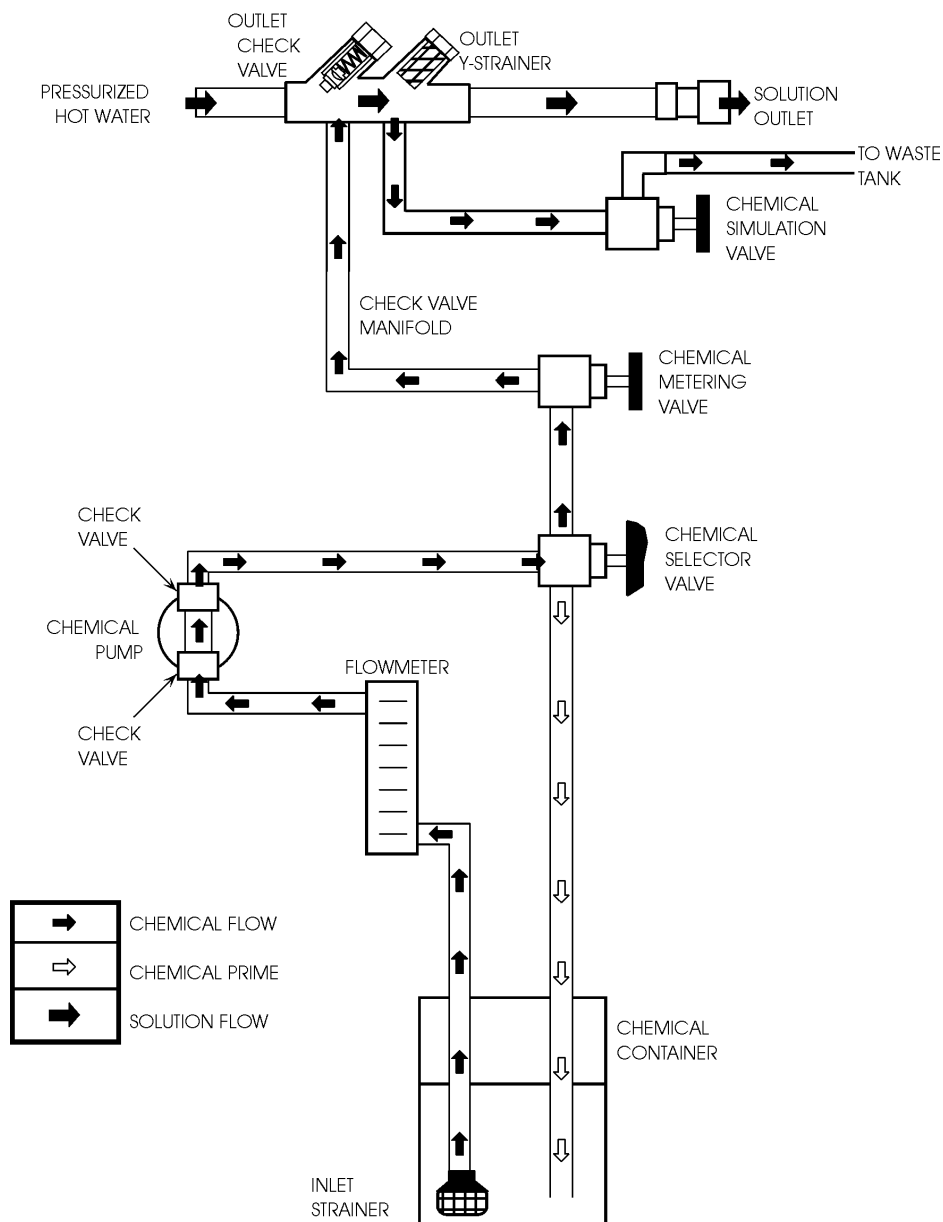



# OPERATIONS

## VACUUM SYSTEM

The engine turning an air pump generates vacuum. The air is channeled in one side of the vacuum pump, compressed and discharged on the opposite side, creating airflow.

The movement of air is used to do the work necessary for the extraction process. A vacuum nozzle applied to the carpet surface removes moisture, dirt and spent chemicals. These elements are conveyed back to a separating tank utilizing hoses and the force of air. Particles of moisture and dirt are separated in the vacuum tank using a series of changes in direction and velocity. The air is then filtered and rushes into the vacuum pump.

The vacuum pump compresses and heats the incoming air. The hot discharged air is forced downstream into a silencer for noise abatement. After exiting the silencer, this hot air is mixed with hot gases from the engine. This mixture of hot gases are then forced through 3 radiators serving as heat collectors. Heat from the engine and vacuum pump is then transferred into the plumbing system raising the water temperature for better cleaning.

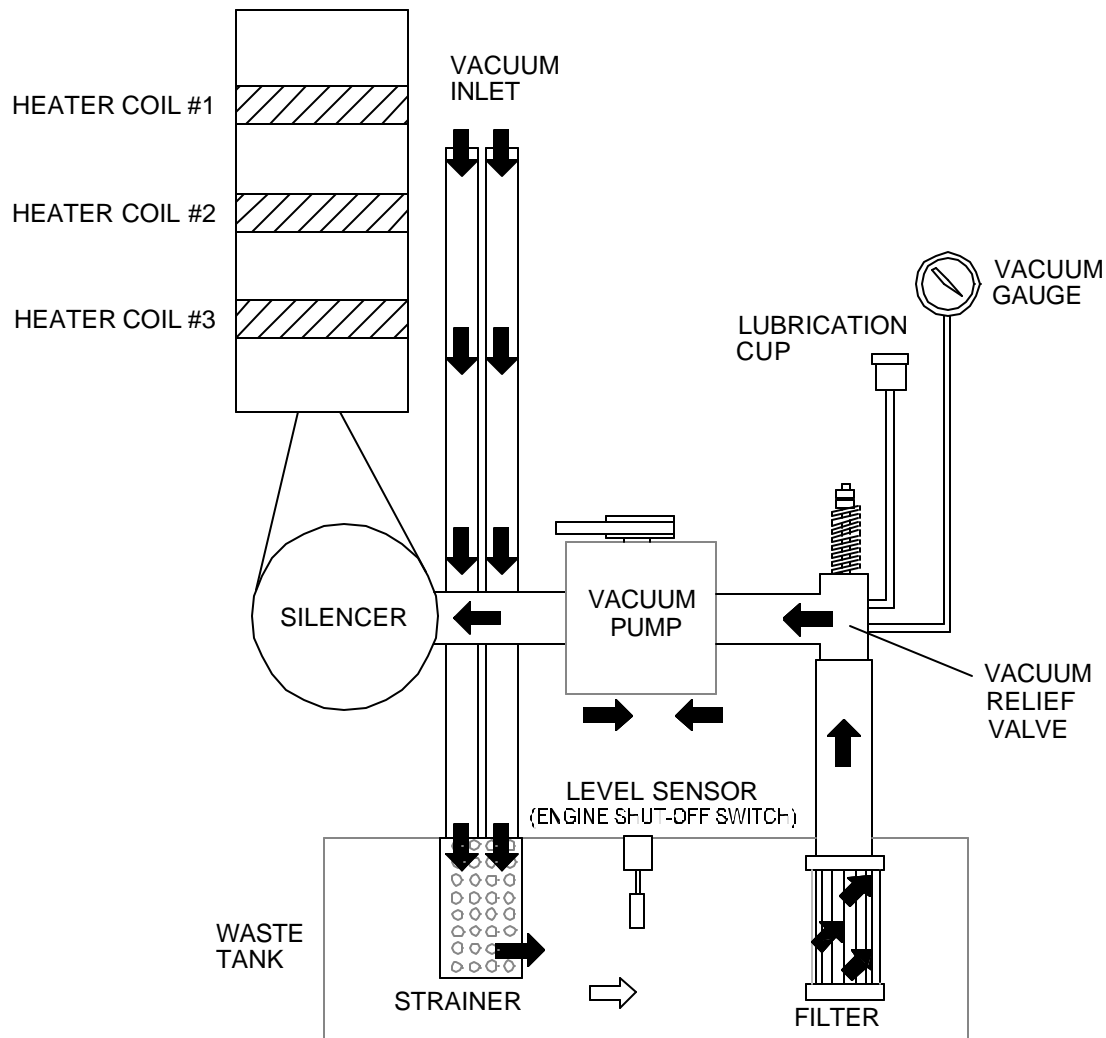

## PRE-RUN INSPECTION

*NOTE: Operation of this unit is simple. However, only trained personnel should proceed.*

### **⚠ WARNING:**

Operate this unit and equipment only in a well-ventilated area. Exhaust fumes contain carbon monoxide which is an odorless and deadly poison that can cause severe injury or fatality. **DO NOT** operate this unit where the exhaust may enter any building doorway, window, vent, or opening of any type. Do not operate this unit while the exhaust discharge is directed at plants or animals.

## CHECK FOR ADEQUATE FUEL

Check the fuel tank to be certain there is adequate fuel to complete the job. This unit uses approximately .95 to 1.18 gallons of fuel per hour, depending on the speed setting.

## REMOVE TOOLS FROM VEHICLE

Remove any **tools** or **hoses** from the van which you will require.

## WATER SUPPLY CONNECTION

*NOTE: Before connecting your water hose to the supply faucet, flush out the faucet until the water is free of any debris. Flush out any debris which may be in your water inlet hose.*

1. Connect the **water supply hose** to the **water inlet** quick-connect at the left front of the console. Connect the hose to the water supply faucet.

*NOTE: Never use your waste pump outlet hose as a water inlet hose. Use only clean hoses for water inlet.*

2. Turn the **water supply faucet** on. The water will fill the **water box**.

## PRESSURE HOSE

Before starting the unit, connect the **pressure hose(s)** to the **outlet connection(s)** at the front of the unit. Connect the **cleaning tool(s)** to the **pressure hose(s)**.

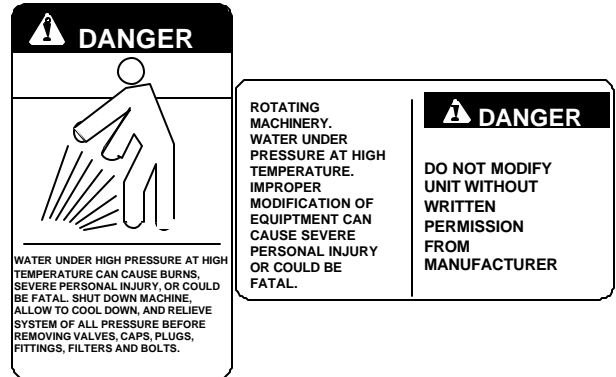

## VACUUM HOSE

Connect the **vacuum hose(s)** to the **vacuum inlet** connection(s) at the front of the unit. Connect the other end of the **vacuum hose(s)** to the **cleaning tool(s)**.

# OPERATIONS

## PRIMING THE CHEMICAL PUMP

1. Connect water hose to water inlet connection and turn on water supply.
2. Connect cleaning and vacuum hoses to the desired cleaning tool and console.
3. Insert chemical inlet and prime tubing into chemical container.
4. Turn ignition key to start.
5. Set throttle to low speed.
6. Fill chemical container and inspect chemical filter.
7. Turn chemical prime valve to prime and allow chemical to circulate. After all air bubbles have been removed from chemical tubing, turn the valve to the horizontal (off) position and open the chemical metering valve, and the simulation valve. Set the desired chemical flow rate while observing the flow meter indicator. Simulator valve must be in the open position to set chemical flow. When desired flow is reached turn simulator valve off.
8. Set throttle to maximum position with vacuum ports blocked off for quick unit heat up.

## WASTE PUMP (OPTIONAL)

1. If your unit is equipped with an automatic waste pump, connect one end of a garden hose to the pump-out connection on the console and the other end to an appropriate waste disposal.
2. Turn the pump-out switch on the control panel to the ON position. Turn the toggle switch on the pump unit to "ON". The waste pump will operate automatically throughout the cleaning operation.

We recommend that you use a 3/4" I.D. water hose as a waste pump outlet hose. DO NOT use a hose smaller than 5/8" I.D.

NEVER use your automatic waste pump outlet hose as a water inlet hose.

## WARNING:

**NEVER dispose of waste in storm drains, water ways, or on ground areas. Always dispose of waste in accordance with Local, State, and Federal laws.**

Your unit should be in the correct throttle position for your cleaning operation or extracting. A float switch located inside the waste tank will automatically shut down the unit when it reaches its full capacity. When this occurs, empty the waste tank before continuing.

## CLEANING

Observe the following guidelines, while cleaning:

1. Before proceeding make sure the nozzles are functioning properly.
  - a. To check, hold the wand about one foot above the surface to be cleaned and open the wand valve. A full spray should be observed from the cleaning nozzles.
  - b. If the nozzles are not showing a full spray pattern, adjust nozzles for proper pattern, clean, or replace nozzles, if required.
2. Normally chemical is applied on the push stroke of the wand when cleaning and vacuuming is done on the pull stroke. For heavily soiled carpets the wand may be used in a scrubbing manner, apply chemical in both push and pull strokes. Always finish up an area with a vacuum stroke.
3. When cleaning, keep the working opening (mouth) flat on the surface being cleaned. Keep the wand moving when the valve is open.
4. The unit will automatically shut-down when the waste tank is full. This will prevent water being drawn into the vacuum pump. If shut-down occurs, empty the waste tank before proceeding.

## UPHOLSTERY CLEANING

Upholstery tool, part #78513

1. Set engine speed control to “Low/Upholstery” setting to minimize excess heat.
2. Use one (1) “80015” spray tip in tool.

## SHUTDOWN AND DAILY MAINTENANCE (LOW PRESSURE)

1. Close chemical metering valve.
2. Allow the unit to run for 2 minutes with the vacuum hose disconnected to remove moisture. Spray WD40 (or equivalent) into the vacuum lubrication cup. This will prevent corrosion due to moisture.
3. Set engine speed control to idle position and allow the water temperature to cool down, unitizing the simulator valve in the open position to bleed off residual hot water left in the system.
4. Turn off ignition switch.
5. Disconnect all hoses and tools.
6. Drain waste tank.

## HIGH PRESSURE (3000 PSI) SYSTEM OPERATION (OPTIONAL)

### CAUTION:

The high-pressure water system can produce water pressures in excess of 3000psi. Water at these pressures will cause severe injury. DO NOT direct any discharges at persons. If contact with a person does occur and penetration of the skin does seem possible, contact medical personnel immediately. This machine is to be used by trained cleaning professionals only. Ensure all operators are trained in the operation of this equipment. Keep cleaning area clear of all persons and objects.

Ensure that proper Personal Protective Equipment (PPE) is used during the operation of this equipment. Failure to use proper PPE could result in injury. Ensure required ventilation and/or breathing apparatuses are used with a chemical injection system. Check with your chemical vendor for proper safety requirements.

## OPERATION

The “HP” units are equipped with a water pump and water delivery system that can support pressure-washing operations up to 4.5 gallons per minute at 3000 PSI. This system is normally used for high-pressure washing and hard surface cleaning.

1. Move the temperature selection valve from the “hot” position to the “warm” position.
2. Allow water temperature to cool to below 160 deg F.
3. Close ball valve located between the chemical pump and the water pump.

### CAUTION:

**Failure to close this valve will result in severe damage to the chemical pump diaphragms.**

4. Connect hose and either pressure washer gun or hard surface cleaning tool to high pressure disconnect.
5. Move the pressure selection valve from the “low pressure” position to the “high pressure” position.
6. Adjust high-pressure regulator to desired operational pressure.

## OPERATIONS

### HIGH PRESSURE SHUTDOWN & RETURN TO LOW PRESSURE SYSTEM

1. Adjust High Pressure regulator to set pressure at 400 psi.
2. Bleed off excessive pressure build-up by operating pressure washer gun for 5 seconds.
3. Move solution selector control valve from "High Pressure" operations to "Low Pressure" operations.
4. Squeeze pressure washer gun trigger again to remove any residual pressure
5. Disconnect high pressure gun and hose from high pressure disconnect.
6. Operate under normal low pressure instruction or follow normal shutdown procedures.

Pro-Chem recommends the use of the **Pro-Chem chemical injector (P/N 61-951538)** for use in combination with any chemical/detergent additives.

Pro-Chem also recommends the use of Pro-Chem high-pressure spray wands. Pro-Chem offers a **dual barrel wand (P/N 60-950505)**. Contact your Pro-Chem dealer for recommendations in your particular application.

The operation of the high-pressure system also requires a high-pressure hose capable of handling the increased pressure loads of the high-pressure system. NEVER use your low-pressure system hoses with the high-pressure system. Pro-Chem offers a special **high pressure hose, P/N 10-805513**, rated for pressure washer activities. Only use Pro-Chem approved hoses and fittings. Ensure that your hoses and fittings are rated for your operational pressures.

### DE-FLOODING OPERATIONS

De-flooding operations involve removal of water from carpet and flooring. This differs from normal cleaning operations in that no water or solution is required. An automatic waste pump-out is highly recommended for all de-flooding operations due to the large amount of water removal often required.

1. Move the temperature selection valve from the "hot" position to the "warm" position.
2. Ensure that the system is operating in low-pressure mode (HP units only). Adjust low-pressure regulator to set pressure at 100 psi. If not hooked up to a water source, leave solution pump turned off.
3. Allow solution temperature to cool below 160 deg F.
4. Begin de-flooding operation.

### FREEZING PROTECTION

#### CAUTION:

If the unit is exposed to freezing weather the water in the unit may freeze, causing **SERIOUS DAMAGE** to the unit. To avoid this, the following is recommended during the cold weather season.

When the unit is not in use, always park it in a heated building.

While in operation, avoid long shutdowns as the unit provides heat while running. Shut it down just prior to leaving for the next job.

If a heated building is not available, we recommend that you winterize the unit with anti-freeze. At present, it is only possible to winterize units, which do not have an auxiliary water tank. Units with auxiliary water tanks must be stored in a heated building when not in use.

## WINTERIZING YOUR UNIT

1. Shut off the water supply. Disconnect the **water inlet hose** from the front of your console.
2. Connect all **pressure hoses and tools** that may have water in them.
3. Start the unit and turn water pump on. Open the tool valve until water pressure drops and water stops flowing.
4. Fill the water box with approximately two gallons of 100% glycol base anti-freeze.
5. Start the unit.
6. Open the tool valve until anti-freeze begins to come out of the tool. Recover **ALL** anti-freeze that comes out of the tools into an approved container. We strongly recommend that you recycle and re-use the anti-freeze.

Repeat this procedure with all the remaining tools. After all tools and pressure hoses have been filled with anti-freeze, disconnect and store them.

7. Turn the **solution pump switch** OFF. Attach the **winterizing loop hose** with attachment, Part #10-805380, to the bottom solution outlet connection and the water inlet connection. Turn the **solution pump switch** ON.

Allow the unit to run for approximately 3 minutes with the winterizing loop hose attached.

8. Prime the chemical system with 50/50 anti-freeze/water mix. Insert the chemical inlet and prime discharge tubes into the anti-freeze container. Turn the chemical valve to PRIME until anti-freeze begins to flow out of the prime hose.
9. Now turn the chemical valve and flow simulator valves to the open position, making certain that the flow meter indicates flow and that all anti-freeze drains out of the chemical hose into an approved container, after 30 seconds, turn off both valves.

## HIGH PRESSURE

Turn solution pressure valve to high pressure and key the high pressure wand until anti-freeze begins to come out of the wand. Recover all anti-freeze into an approved container. We strongly recommend that you recycle and re-use the anti-freeze.

After completing these procedures, shut the unit down. The unit is now winterized.

## OPERATIONS

### REMOVING ANTI-FREEZE FROM THE UNIT

1. Connect one end of the **winterizing loop hose** to the bottom solution outlet connection. Place the other end of the loop hose, without the attachment, into an approved container.
2. Start the unit. Allow the anti-freeze to flow into the container until flow stops.
3. Fill the water box with fresh water and repeat step #2.
4. Connect the **water inlet hose** to the water inlet connection on the console. Turn the water supply on.
5. Connect all **solution hoses and any tools** which require purging of anti-freeze to the solution outlet connection(s).
6. Open the tool valves and drain the anti-freeze into an approved container until the flow is clear and all anti-freeze is purged from the tools and hoses.

7. Place the chemical prime hose into the approved container. Submerge the chemical inlet hose in water. Turn the **chemical valve** to the PRIME position until clear water comes through the prime hose, and then remove the prime hose from the container.

Turn the **chemical valve** to the ON (CHEMICAL) position. This will allow water to flow into the other side of the system.

Once all of the anti-freeze is removed, the unit is ready to use.

Eventually, the anti-freeze in your storage container will become diluted with water. If the anti-freeze level drops below 50% of the total, dispose of it and start with fresh 100% anti-freeze.



**When disposing of used anti-freeze, observe local laws and regulations. Do not drain onto the ground or into storm drainage systems.**

**NOTES:**



# MAINTENANCE

## SERVICE SCHEDULE

<b>Engine</b>	Daily	Check engine oil level. *** Fill to proper level
<b>Engine</b>	Daily	Check coolant level in overflow bottle
<b>Vacuum Pump</b>	Daily	Spray WD-40 in lubrication cup at front of console for 5 sec.
<b>Water Pump</b>	Daily	Check oil level.** Fill to proper level
<b>Solution Inlet Tube Strainer</b>	Daily	Check strainer for blockage, remove any debris
<b>Vacuum Inlet Filter (In Waste Tank)</b>	Daily	Clean filter, inspect, replace if damaged
<b>Vacuum Hoses</b>	Daily	Wash out with clean water
<b>Automatic Waste Pump</b>	Daily	Inspect and remove any debris or sediment
<b>Chemical Filter</b>	Daily	Inspect daily
<b>Vacuum Pump</b>	Weekly*	Check oil level. Fill to proper level
<b>Water Box Float Valve</b>	Weekly	Check for proper seating and shut-off
<b>Water Pump Inlet Filter</b>	Weekly*	Check for debris and clean
<b>Temperature Balance Orifice</b>	Weekly	Remove, clean and check
<b>Battery</b>	Weekly*	Check for proper fluid level. Fill with distilled water only
<b>Solution Outlet Y-Strainer</b>	Bi-Weekly*	Inspect and remove any debris or blockage
<b>High Pressure Hoses</b>	100 hrs	Inspect for damage or impending damage
<b>Pressure Regulators</b>	100 hrs	Lubricate o-rings
<b>Engine</b>	100 hrs	Change engine oil***
<b>Engine</b>	100 hrs	Change oil filter***
<b>Engine</b>	100 hrs	Check fan belt tightness
<b>Battery</b>	100 hrs*	Clean battery terminals
<b>Float Valve Seal</b>	200 hrs.	Replace seal
<b>Engine</b>	200 hrs	Check radiator hoses and clamp tightness
<b>Fuel Pump</b>	200 hrs	Check hose connections and wire connections
<b>Flow Simulator And Chemical Valves</b>	200 hrs	Inspect and/or adjust packing nuts
<b>Engine</b>	250 hrs	Service air cleaner elements*
<b>Engine</b>	250 hrs	Check spark plugs for carbon deposits and proper gap
<b>Intake &amp; Exhaust Valve Clearances</b>	250hrs/ 1500 hrs	Check operating temperature
<b>Cylinder Head Bolts &amp; Manifold Nuts</b>	250 hrs/ 2000 hrs	Retighten
<b>Ignition Timing</b>	250 hrs	Inspect
<b>PCV Valve/hoses</b>	750 hrs	Inspect
<b>I.C. Ignition Distributor</b>		

# MAINTENANCE

## SERVICE SCHEDULE

<b>Vacuum Exhaust Heat Exchanger</b>	500 hrs	Inspect cores and remove debris.
<b>Water Pump</b>	500 hrs	Change oil**
<b>Pulley Set Screws &amp; Hub Cap Screws, Water Pump Clutch Shaft Bolts</b>	500 hrs	Check for proper torque valves. Re-torque, if required****
<b>Drive Pulley</b>	500 hrs	Inspect, clean and check for pulley groove wear****
<b>Drive Pulley</b>	500 hrs	Check pulley alignment****
<b>Drive Belts</b>	500 hrs	Inspect and clean****
<b>Drive Belts</b>	500 hrs	Check belt tension****
<b>Chemical Pump &amp; Check Valves</b>	500 hrs	Replace diaphragm and check valves.
<b>Heater Core</b>	500 hrs	Clean and inspect.
<b>Engine</b>	1000 hrs	Replace spark plugs.
<b>Check Valve (Solution Outlet)</b>	1000 hrs	Inspect, clean, and repair, if needed.
<b>Vacuum Pump</b>	1500 hrs	Drain, flush, and replace oil *****
<b>Fuel Filter</b>	1500 hrs	Replace
<b>Engine</b>	Yearly	Flush radiator and change engine coolant.
<b>Engine</b>	Yearly*	Replace air cleaner elements.
<b>Nitrogen Accumulator</b>	Yearly*	Replace Accumulator.
<b>Waste Tank Filters/Strainers</b>	Yearly	Check for damage and blockage. Replace if needed.
<b>Engine</b>	2 years	Replace radiator hoses and hose clamps.
<b>Engine</b>	3 years	Replace ignition wires.

\* Or as often as required

\*\* Change water pump crankcase oil after the first 50 hours

\*\*\*Change engine crankcase oil and filter after the first 50 hours

\*\*\*\*Perform drive belt, pulley and hub maintenance after the first 25 hours of operation, and then again at 100 hours

\*\*\*\*\*If using AEON PD synthetic lubricant, 4500 hours or every 2 years, whichever comes first

## **MAINTENANCE**

### **KEY CHECKPOINTS**

*Note: Initiation of a planned preventative maintenance program will assure that your unit has optimum performance, a long operating life, and a minimal amount of "down" time.*

### **ENGINE COOLANT SYSTEM (RADIATOR) MAINTENANCE**

Your engine radiator coolant system is an important part of the power plant operation. In addition, this heat exchange system is used to provide heat for cleaning operations is also highly dependent on the engine coolant system. Follow the recommended coolant system maintenance in the Maintenance Schedule in this manual and your Nissan A-15 engine owner's manual. Refer any additional questions to your dealer.

### **EXTERNAL FUEL PUMP MAINTENANCE**

The power plant for unit receives fuel from the main gas tank of your van/truck. An external fuel pump that provides this fuel is located on the underside of the van/truck. Loose fittings and hose connections will cause your unit to perform poorly. Follow the recommended fuel pump maintenance in the Maintenance Schedule in this manual. Refer any additional questions to your dealer.

### **SOLUTION SUPPLY SYSTEM MAINTENANCE**

The chemical supply system pulls chemicals from your chemical bottle utilizing a pump that works off the water pump pulsing. Any clogged filters or loose connections will result in a chemical supply system malfunction or a malfunction at the cleaning tool. Maintenance of the solution outlet check valve and strainer are vital to effective cleaning operation and minimal unit downtime. Additionally, the hoses related to supplying water and chemical to the outlet manifold are under high pressures and experience thermal expansion and contraction. Periodic inspections of these hoses for tears, cracks, and failing connectors are necessary to avoid unwanted leaks. To keep your solution supply system functioning properly, follow the chemical pump and solution outlet maintenance in the Maintenance Schedule in this manual. Refer any additional questions to your dealer.

### **HEAT EXCHANGER SYSTEM MAINTENANCE**

The heat exchange system in your unit transfers energy between the unwanted heat of the power plant and the solution supply system of the unit. The heat transfer of this system is highly dependent on the surface area contact in the heat exchanger cores located in the heat exchanger box. This surface area amount is adversely minimized when the supplied water is not softened to recommended levels. Hard water will result in scaling on the inside walls of the heat exchanger tubes. It is recommended that you use a dealer approved water softener to avoid premature heat exchanger core failure. Contact your local dealer for advice on the water hardness levels in your area.

Additionally, the heat exchanger tubes are very sensitive to freezing conditions. As the water freezes during cold conditions, it expands in the heat exchanger tubes and causes damage. Refer to the Freeze Protection instructions section in this manual. Refer any additional questions to your dealer.

### **VACUUM PUMP MAINTENANCE**

The total function of the unit is based around the performance of the vacuum pump. Heat transfer used to raise the temperature of the solution is gained from the air drawn by the vacuum pump and solution is removed from the carpet with the vacuum suction of the vacuum pump. General maintenance actions for the vacuum pump as listed in this manual are vital to prolonged vacuum pump operations. Daily lubrication of the pump is required to avoid seizure of the system. Also, waste tank filters and strainers must be maintained to prevent unwanted debris from entering the vacuum pump.

## **WARNING:**

**DO NOT** service this unit while it is running. The high-speed mechanical parts as well as high temperature components may result in severe injury, severed limbs, or fatality.

**NOTE:** Use the hour meter as a guide for coordinating the maintenance schedule.

## ENGINE

1. Check the engine oil level **daily**, when in use. Make certain that proper oil level is maintained. **NEVER** overfill.
2. Change the break-in oil after the first **50 hours** of operation. Thereafter, change oil every **100 hours** of operation. **USE ONLY NISSAN BRAND OIL FILTERS. USING ANY OTHER TYPE OIL FILTER WILL VOID YOUR ENGINE WARRANTY.**

**Oil Recommendation.** Use high-quality detergent oil of at least API (American Petroleum Institute) service class SF or SG. The recommended SAE viscosity grade for summer is **20W-50**, and **20W-40** winter.

**NOTE:** Using less than service class SF or SG oil or extending oil change intervals longer than recommended can cause engine damage.

3. Re-torque the manifold and exhaust tube nuts, cylinder head bolts, and carburetor attaching nuts after the **first 250 hours** of use.
4. Check the spark plugs every **250 hours**. Clean if necessary. Replace the spark plugs every **1000 hours**. **NOTE:** Never sandblast spark plugs. Spark plugs should be cleaned by scraping or wire brushing.

Clean the air cleaner element every **250 hours**. Replace the element every **2400 hours**

5. Check the coolant level in the radiator overflow container **daily**. If no coolant is seen, remove the cap and add coolant. Change the coolant with a 70:30 coolant to water ratio every **1000 hours or 2 years**.
6. Replace the in-line gas filter under the vehicle **yearly**.

**NOTE:** For additional engine service information, obtain a "Nissan A-15 Service and Repair Manual" from any authorized Nissan Service Center. If service or repair is required, contact an authorized Nissan Service Center. You will need to provide the serial number of the engine.

# MAINTENANCE

## VACUUM PUMP

Refer to the Vacuum Pump Operation and Service Manual for specific instructions.

**Lubrication:** We recommend that you use AEON PD Synthetic Blower Lubricant in the gear end of the vacuum pump for all operating temperatures. AEON PD is formulated especially for positive displacement blower service to provide maximum blower protection at any temperature. One filling of AEON PD will last several times longer than a premium mineral oil.

**NOTE: AEON PD (Part# 05-008039) is the oil which PROCHEM puts in the vacuum pump at the factory. Topping off or adding petroleum oil to synthetic oil is NOT recommended.**

*If not using AEON PD synthetic blower lubricant, use oils with rust and oxidation inhibitors, anti-foam additives and the viscosity's listed on the chart on the next page.*

1. Check the oil level **daily** to assure the proper level. **PROPER LEVEL** cannot be overemphasized. Too little oil will ruin bearings and gears. Too much oil will cause overheating. Use the illustration as a guide when adding oil.

2. To prevent rust from building up inside the vacuum pump (if moisture exists) we have provided a lubrication cup on the front of the unit.

First run the unit at least **1 minute** to remove any moisture from the vacuum pump. Next, fill the lubrication cup with WD-40, or a similar lubricant, for **5 seconds** while the unit is running and the vacuum inlets are sealed. Do this at the end of **each working day**.

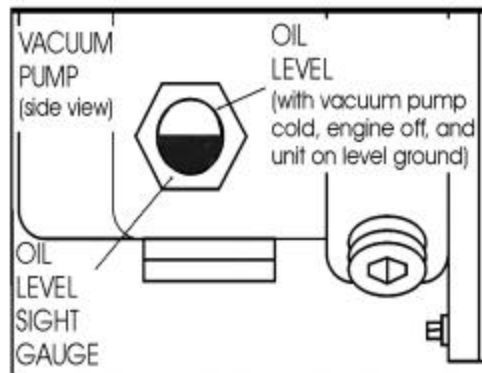

3. Drain, flush and replace oil every 1500 hours or **yearly, whichever comes first**. Change oil more frequently if inspection so indicates. With AEON PD synthetic lubricant, perform the oil change maintenance **every 4500 hours or every 2 years, whichever comes first**.

## WATER PUMP

Refer to the Water Pump Operation and Service Manual for specific instructions.

1. Check the crankcase oil level **daily** to assure the proper level. Use the illustration as a guide when checking the oil level. If the level has dropped, check for the source of leakage and repair.
2. Use the provided dipstick. Remove red filler cap and insert dipstick. Oil level should be between marks on the dipstick or use a mirror and refer to the illustration.

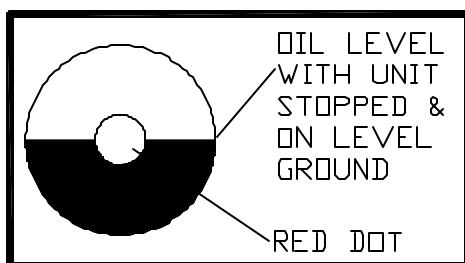

3. Change the crankcase oil with Cat Pump Crankcase Oil, Part #05-008016, after the **first 50 hours** of operation. Drain and refill the crankcase oil with Cat Pump Crankcase Oil **every 500 hours** thereafter.
4. Other Cat approved oil equivalents are: Mobil DTE 16, Amoco Rykow 68, and Shell Tellus T68.

## VACUUM INLET FILTER (IN WASTE TANK)

1. The vacuum filter in the waste tank should be removed and cleaned **daily**. If this is done, the filter will last for a long period of time.

## VACUUM RELIEF VALVE

While the unit is running at full RPM, block the air flow at the vacuum inlet connection and read the vacuum gauge. If adjustment is required, shut the unit down and adjust the vacuum relief valve locking nut tension. Start your unit and read the vacuum gauge. Repeat this process until the relief valve opens at 13" Hg.

## VACUUM PUMP DRIVE BELTS

To tighten the vacuum pump belts:

1. Loosen the four screws which hold the vacuum pump spacers in place on the bottom side of the adjusting plate.
2. Loosen the 6 bolts at the vacuum muffler outlet to heat exchanger box and loosen the bolt at the back of the machine connecting the muffler bracket to the frame.
3. Turn the adjusting bolts until the proper belt tension is achieved (1/2" deflection in the center of the belt, halfway between the pulleys).

4. Retighten all bolts previously loosened at the vacuum muffler.

**NOTE: When adjusting belt tension, make certain that the engine shaft and vacuum pump shaft remain parallel, and the belt tension is equal throughout the belt width.**

5. After adjusting, re-tighten the four screws which hold the vacuum pump spacers in position. Check belt alignment with straight-edge.

### CAUTION:

**Make certain that when you re-torque these screws, that you use a clockwise pattern and continue until proper torque is achieved.**

TORQUE VALUES		
COMPONENT	INCH/LBS	FOOT/LBS
Engine hub	480	40
Vacuum pump hub	300	25

6. Check for pulley groove wear, clean belts and pulley grooves, check for worn belts, proper belt tension, and pulley alignment after the **first 25 hours** and then again at **100 hours**. Check for belt ride in the groove.

## MAINTENANCE

### WATER PUMP DRIVE BELT

To tighten the water pump belt:

1. Loosen the nuts which hold the water pump mount to base.
2. Turn the belt tension adjusting bolt until the proper belt tension is achieved. (1/2" deflection in the center of the belt, halfway between the pulleys).
3. While checking the alignment, tighten the nuts which hold the water pump mount to base.

### WATER PUMP CLUTCH



After removing or replacing water pump clutch, make certain that bolt is re-torqued to the proper value.

Torque Value		
Component	Inch pounds	Foot pounds
Water pump shaft bolt	192	16

### FLOAT VALVE (WATER BOX)

The float valve should only be adjusted if the water box is overflowing or the water level in the box is lower than 5-1/2".

1. If the box is overflowing, remove, and check the float valve for debris or damage.

**NOTE:** If the float ball has any water inside it must be replaced.



**When replacing float ball, DO NOT over-tighten, as the rod can puncture the ball. Make sure to tighten the nuts on the rod.**

2. Disassemble the valve and check the piston and seat for damage, replace if needed. See the "Illustrated Parts Listing" for a parts break-down.

### WASTE TANK STRAINER BASKET

The strainer basket located inside the waste tank should be removed and cleaned whenever it is full of debris. This should be done at the end of each job.

### Y-STRAINER (OUTLET)

Inspect the Y-strainer **after the first week** of running the unit by unscrewing the screen and remove any accumulated debris. Inspect the strainer again every **2 weeks**.

The Y-strainer should then be inspected **every month**. However, if the Y-strainer has a frequent build-up of debris it should be inspected and cleaned more often.

### TEMPERATURE BALANCE ORIFICE

Inspect the Temperature Balance Orifice every week. Be sure to drain the water box below 1/2 full. Clean as necessary. The orifice needs to be kept clean. Cleaning in this way will be dependent on the water hardness you are using.

### CHECK VALVE (OUTLET)

Inspect the check valve when rebuilding the chemical pump or as needed. Remove and disassemble the check valve. Check the Teflon seat for debris or abnormal wear. Clean or replace seat if needed.

**NOTE:** Improper seating of the check valve poppet, damaged spring, or o-rings will cause poor operation of the chemical system.

For the procedure, see the "General Service Adjustments" section in this manual for details.

### CHEMICAL PUMP

Rebuild the chemical pump **every 500 hours**. This involves changing the diaphragm and check valves.

For the procedure, see the "Chemical Pump" section in this manual for details.

**NOTE:** *Inspect chemical filter daily.*

## NITROGEN ACCUMULATOR

The nitrogen accumulator is pressurized to 250 PSI and must be replaced periodically. The accumulator cannot be repaired or recharged. We recommend replacement every 1000 hours of use or yearly, whichever comes first.

## PRESSURE REGULATOR

Lubricate the o-rings **every 50 hours**. Use o-ring lubricant Part #05-008035.

For the procedure, see the "General Service Adjustments" section in this manual for details.

## VACUUM HOSES

To assure maximum hose life, we recommend that the hoses be washed out with clean water at the end of each **working day**.

## PRESSURE HOSES

Inspect your pressure hoses for wear after the **first 100 hours** of use. Inspect **every 25 hours thereafter**. If hoses show any signs of damage or impending rupture, **replace the hose**.



**DO NOT attempt to repair pressure hoses!**  
Repairing pressure hoses may result in severe burns and serious injury!

**All pressure hoses must be rated for 3000 PSI at 250°F. Thermoplastic hoses do not meet these specifications and should not be used.**

## OPTIONAL WASTE PUMP-OUT

**At the end of each work day**, make certain that you remove any debris or sediment which may be inside the waste pump by pumping fresh water through the pump.

## CHEMICAL AND SIMULATOR VALVE

Examine the packing nut on the chemical prime selector valve, flow simulator valve, and chemical metering valve **every 200 hours**.

Keeping these valve packings properly adjusted will eliminate possible leakage from the valve stems and add to overall valve life.

For the procedure, see the "General Service Adjustments" section in this manual for details.

## ENGINE COOLANT REPLACEMENT

Annually the coolant in the Prochem machine should be replaced. This coolant is an integral part of the heating system and needs to be maintained as any other working part of the system. We recommend that this procedure be accomplished by the following steps.

### DRAINING COOLANT:

1. Add 7/16" hose or a 1/4" plastic hose into the radiator drain petcock. Turn counter clockwise to open and drain coolant. After draining approximately 1/2 gallon, open bleed petcock in heli-coil to assure that heli-coil drains also. Allow the coolant to completely drain.

**NOTE: Be sure that used coolant is collected in a proper container and disposed of in accordance with local laws.**

2. After draining is complete, close both the radiator and heli-coil petcocks. Draining is complete.

### REPLACING COOLANT:

1. Fill radiator with 70/30 anti-freeze water mix.
2. Start unit and run on low speed.
3. As the unit warms up, maintain a full radiator with a 70/30 mix.
4. Open petcock slightly on heli-coil to allow any trapped air to escape. When coolant runs out of heli-coil, close petcock.
5. Fill radiator with 70/30 coolant mix.
6. Re-install radiator cap.
7. Shutdown unit.

Check radiator overflow bottle. Add coolant to proper "cold" level.



## MAINTENANCE

### CHECK VALVE (SOLUTION OUTLET)

Inspect the check valve whenever doing service on the chemical pump or if flow problems occur in the chemical system:

1. Remove the check valve. Be sure the small o-ring for the seat comes out with the check valve.
2. Remove the seat, using a 5/16" Allen wrench.
3. Check the Teflon seat for debris or wear. Clean or replace Teflon seat if needed.
4. Clean the poppet and spring, inspect for wear or damage, and replace as needed.
5. Re-assemble the check valve. Start the seat by hand, tighten using a 5/16" Allen wrench. **DO NOT** over-tighten seat.

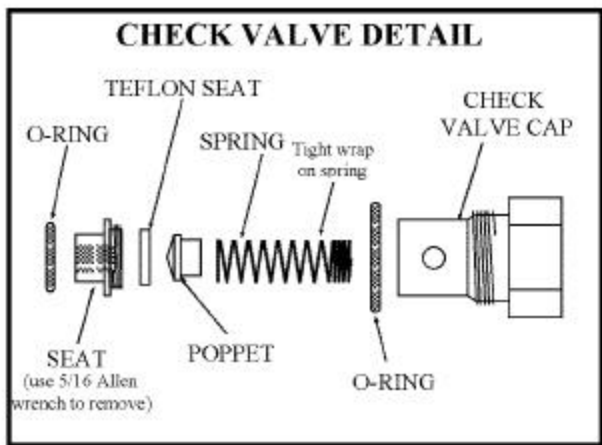

**NOTE: Improper seating of the check valve poppet, damaged spring or o-rings will cause poor operation of the chemical system.**

6. Lubricate the o-rings with o-ring lubricant Part #05-008035 and reinstall.

### CHEMICAL PUMP

The only repairs which the chemical pump may require is the replacement of the diaphragm or check valves. To replace the diaphragm, unscrew the cover from the body. When replacing the diaphragm, lubricate the outer edges of the diaphragm with o-ring lubricant Part #05-008035 and reassemble. To replace the check valves, unscrew the check valve caps. Replace the check valves and reassemble, using new o-rings.

**DO NOT** attempt to re-use o-rings once the check valves have been removed. See the "Illustrated Parts Listing" for a parts break-down on the chemical pump.

## PACKING NUT ADJUSTMENT FOR CHEMICAL METERING, FLOW SIMULATOR AND CHEMICAL SELECTOR VALVES

Examine the packing nut on the chemical metering, flow simulator, and chemical selector valves for proper tension every **200 hours**. When turning the knob, there should be a small amount of resistance. If not, slightly tighten the packing nut. **DO NOT** over-tighten. Keeping the valve packings properly adjusted will eliminate possible leakage from the valve stems and add to overall valve life.

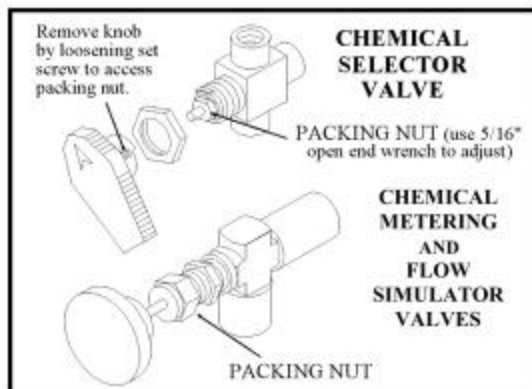

## PRESSURE REGULATORS

The pressure regulators hold water pressure at a preset point and bypass excess water back to the water box.

### LOW PRESSURE REGULATOR

To adjust:

1. With your unit running, close the cleaning tool. Check the pressure gauge. Open the tool valve. We recommend setting the pressure regulator so that the pressure gauge reads 350 PSI with the tool valve **open**.

When the tool valve is opened, there is an approximate drop of 100 PSI in pressure. **If there is a pressure drop greater than 100 PSI, it may be necessary to lubricate the o-rings in the pressure regulator.**

2. If the pressure regulator requires adjustment, turn the adjusting knob (while observing the pressure gauge on the control panel) until the desired pressure is obtained.

### HIGH PRESSURE REGULATOR

To adjust:

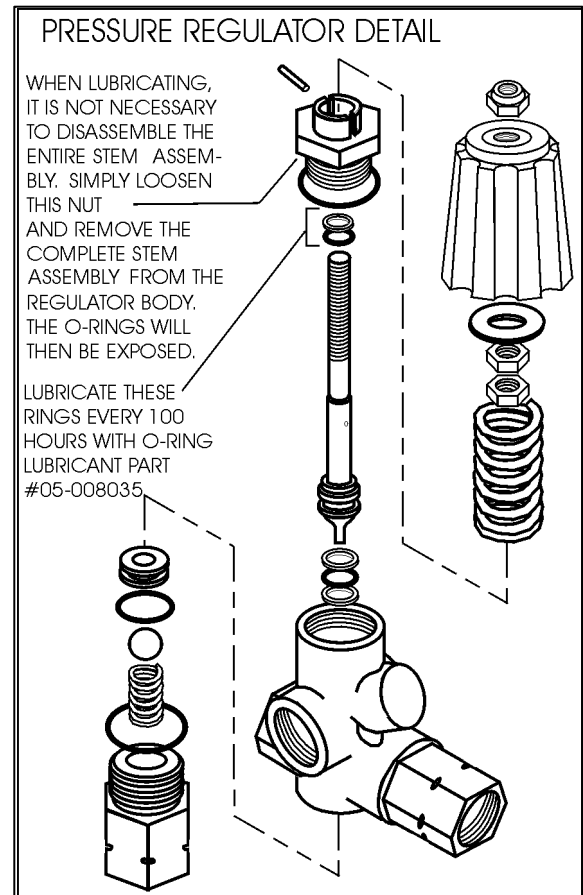

Set the high pressure regulator to desired pressure, up to 3000 PSI. Adjust as necessary to meet your cleaning needs.

Wiring Harness:

1. If you find it necessary to disconnect the Amp connectors joining the harness to the ECU, be sure to apply dielectric grease gel (p/n ) to the female Amp connector prior to re-connection.

## TROUBLESHOOTING

PROBLEM	CAUSE	SOLUTION
<p>Loss of water pump pressure.</p> <p>With the cleaning tool open, the water pressure gauge reads below the normal operating pressure.</p>	Water supply is turned off or the float valve is stuck or improperly adjusted.	Turn the water supply on or up. Check for kinks in the water supply hose. Examine the float valve and adjust or replace.
	Water pump inlet supply line is plugged or drawing air.	Examine the water inlet filter inside the water box. Remove accumulated debris and replace if required. Check for suction leaks and loose clamps or fittings. Tighten any loose fittings or clamps. Replace any ruptured hose(s).
	Orifice improperly installed or Improper engine speed	Using a tachometer, check the engine speed. Full throttle engine speed is 2200 RPM. Idle engine speed is 900 RPM.
	Pressure regulator o-rings are dry.	Lubricate o-rings, using o-ring lubricant Part #05-008035.
	Pressure regulator has worn o-rings	Check o-rings. If necessary, replace.
	Pressure regulator is dirty, stuck open, or improperly adjusted.	Clean or repair regulator. Adjust to working pressure. Lubricate o-rings, using o-ring lubricant Part #05-008035.
	Low pump volume. (Measure the amount of water being returned to the water box from the pressure regulator. It should fill a gallon container about every 17 seconds).	Examine the check valves, plunger cups, and cylinder head on the water pump. Repair, whenever required (refer to the water pump service manual).
	Defective water pressure gauge.	Replace gauge
	Orifice (spray nozzle) in the cleaning tool is worn, defective, or wrong size.	Replace Nozzle or change nozzle size.
	Debris clogging water lines or water inlet disconnect.	Clean or replace as needed.
<p>Loss of solution volume at cleaning tool orifice.</p> <p>Water gauge reads normal.</p>	Belts loose or broken	Re-tension or replace as needed.
	Plugged orifice and/or screen in the cleaning tool.	Unplug or replace orifice and/or screen
	Internal block between the pressure regulator manifold and the outlet Y-strainer, or the Y-strainer screen is clogged	Inspect all lines, remove accumulated debris which is blocking proper flow. Replace any defective hoses. Remove, inspect, and clean the Y-strainer screen. De-scale unit and install a water softener, if necessary.
	Outlet check valve is plugged	Examine the check valve, remove any debris
	Defective quick-connect on one or more of the high pressure hoses.	Replace defective quick-connects(s) on high pressure hoses(s).
	Cleaning tool valve is malfunctioning.	Repair or replace valve.
	Hose inner lining is constricted.	Remove restriction or replace hose.
<p>Uneven Temperature Fluctuation</p>	Orifice Damaged or left out.	Inspect and correct.
	Clogged Temperature Balance Orifice.	Maintain Orifice Assembly.

## TROUBLESHOOTING

PROBLEM	CAUSE	SOLUTION
<p>Loss of vacuum</p> <p>While cleaning, the vacuum is not up to specification. Engine RPM is normal.</p>	Waste tank filter or strainer basket is plugged.	Examine the tubing between the vacuum relief valve and the vacuum gauge and remove any blockage.
	Vacuum gauge is giving an improper reading.	Inspect hose(s), repair or replace.
	Vacuum hose(s) is damaged, causing a suction leak.	Inspect the gasket. Repair seal or replace Re-position lid(s).
	Waste tank gaskets not sealing properly, not positioned properly	Unplug vacuum hose or inlet plumbing.
	Plugged vacuum hose or vacuum plumbing between vacuum inlet and strainer basket.	Clean or replace filter. Clean strainer basket.
	Loose vacuum pump drive belts.	Tighten the drive belts
	Waste tank drain valve is damaged or left open, causing a vacuum leak.	Drain the waste tank. Close drain valve, if open. Remove the dump valve and, after inspecting, replace the defective components.
	Vacuum relief valve requires adjustment or has a vacuum leak due to damaged diaphragm.	Re-adjust the vacuum relief valve. If the vacuum does not increase, remove and inspect the relief valve diaphragm. If damaged, replace
	Vacuum exhaust heat exchangers are plugged with lint.	Remove and clean.
	Vacuum pump is worn out.	Replace the vacuum pump.
<p>Loss of chemical</p> <p>With the cleaning tool valve open, no chemical</p>	Chemical pump is improperly primed.	Refer to chemical pump priming instructions.
	The strainer at the inlet end of the chemical inlet line is clogged	Unclog the strainer. If damaged, replace.
	Suction leak in the inlet line leading into the chemical pump.	Inspect inlet lines and flow meter for damage and replace, if required.
	Chemical pump check valve(s) is clogged	Remove any debris from the chemical check valve(s). Replace chemical check valve(s) or seals, if necessary.
	Chemical prime/on-off valve or chemical metering valve is defective.	Replace valve(s).
	Chemical pump diaphragm is ruptured.	Disassemble the chemical pump and replace the damaged diaphragm.
	Defective cylinder in the water pump.	Measure the pump volume. If the pump volume is less than normal, refer to "Loss of Pump Volume" in the Troubleshooting section in this manual.
<p>Chemical flow meter indicates flow with the tool valve closed</p>	External leak in chemical piping	Tighten fittings. Re-apply thread sealant where required. If any fittings are damaged, replace.
	Outlet check valve is full of debris or damaged, not allowing it to close properly	Close the chemical valve on the instrument panel. If the flow meter does not indicate flow, remove debris or replace check valve, if necessary.
	Chemical pump diaphragm is ruptured	Close the chemical valve on the instrument panel. If the flow meter still indicates flow, replace the chemical pump diaphragm.
	Internal leak in chemical valve causing continual flow through prime tube returning to container.	Tighten valve packing nut (see "General Service Adjustments" section in this manual). Replace valve, if necessary.

## TROUBLESHOOTING

PROBLEM	CAUSE	SOLUTION
Water pump does not engage	Solution pump circuit breaker has been tripped	Check the solution pump circuit breaker on the control panel. Press the circuit breaker reset button.
	Defective electrical connection in the console wiring or defective switch.	Examine switch, electrical connections, and wiring. Repair any defective connections. If there is power going to the switch but not going out, replace the defective switch.
	Water pump has not been activated	Turn solution pump switch to on.
	Defective water pump clutch. NOTE: The clutch may be manually set by inserting two 1/4-20 x 1/2 bolts. Line up the holes on the clutch and insert the bolts. To disengage the pump, remove the bolts.	If there is power in the switch, but not power at the clutch, replace the defective wire. If there is power at the clutch, replace the defective switch.
	Loose or broken water pump belts.	Tighten or replace belts.
Engine will not start  The engine does not turn over	Main circuit breaker on the control panel has been tripped.	After inspecting the unit to determine the cause of the tripped circuit breaker, press the reset button.
	Loose or corroded battery.	Clean, tighten, or replace the battery terminals.
	Dead battery.	Recharge or replace battery.
	Defective ignition switch.	Test ignition switch for power going into the switch. If there is power going in but NO power going out, replace the switch.
	Defective starter motor.	Test the starter motor. If necessary replace.
	Vacuum pump seized.	Refer to Sutorbilt Service & Repair Manual.
Starter turns over engine, but will not start	Waste tank is full.	Empty the waste tank.
	Engine temperature has exceeded 240°F, triggering the high temperature switch to shut the unit down.	Determine the cause of overheating before restarting the unit. See "Excessive Heating" in the "Troubleshooting" section of this manual.
	Defective fuel pump.	Replace the fuel pump.
	Loose or broken wires leading to waste tank float switch.	Repair or replace any broken electrical connections.
	Defective float switch in the waste tank.	Check switch for proper operation, replace as necessary.
	Oil pressure switch (located on engine), high temperature switch (located on engine).	Test these components. If any are defective, replace. Consult the Nissan Engine Operation and Maintenance Manual.

## TROUBLESHOOTING

PROBLEM	CAUSE	SOLUTION
Starter turns over engine, but will not start	Engine is malfunctioning	Refer to Nissan Engine Operation and Maintenance Manual.
Engine stops running While doing normal cleaning, the engine stops running	Engine is out of gasoline	Add gasoline to the fuel tank.
	Waste tank is full	Empty waste tank.
	Main or engine circuit breaker on the control panel has been tripped.	After inspecting the unit to determine the cause of the tripped circuit breaker, press the reset button.
	Engine coolant temperture has exceeded 240°F, triggering the high temperature switch to shut the unit down.	Determine the cause of the overheating before restarting the unit. Refer to the Nissan Engine Operation and Maintenance Manual.
	Defective fuel pump.	Replace fuel pump.
	Defective float switch inside the waste tank.	Check switch for proper operaton. Replace as necessary.
	Defective 240°F engine coolant high-temperature shudown switch.	Test switch. If necessary, replace.
	Oil pressure switch on engine has shut down, due to insufficient oil pressure.	Refer to the Nissan Engine Operation and Maintenance Manual. <b>DO NOT</b> restart the engine until the cause is determined and corrected.
	No ignition in the engine or engine is malfunctioning.	Refer to the Nissan Engine Operation and Maintenance Manual.
Excessive heating	Flow restriction caused by hard water scaling.	Descale unit, repair or replace damaged plumbing components as neces sary. Install water softener.
	Not enough water flow.	Check jet size of tool.
Heat exchanger leaks  <b>NOTE:</b> The exhaust heat exchanger will produce water condensation discharge at times during normal operation. <b>DO NOT</b> confuse this with a leak.	Engine/vacuum exhaust heat exchangers are damaged from frozen water.	Inspect heat exchangers for leaks. Visually inspect for damage. Pressure check after removing from the unit. (Maximum test pressure 1200 PSI).
Loss of temperature  The heat output of the unit is LESS than normal.	Temperature relief valve on water box is stuck open.	Clean temperature relief valve and test. Replace, if necessary.
Automatic waste pump is malfunctioning or not operating normally  <b>NOTE:</b> When replacing either the pump or float switch, use new electrical connectors and heat shrink. Inspect connection for watertight seal.	Defective waste pump float switch.	Replace float switch.
	Broken diaphragm.	Replace diaphragm.
	Weak battery.	Charge or replace battery if needed. Check charging station.
	Pump-out circuit breaker on control panel has been tripped.	After inspecting waste pump to determine the cause of the tripped circuit breaker, press the reset button.

# FRAMEWORK

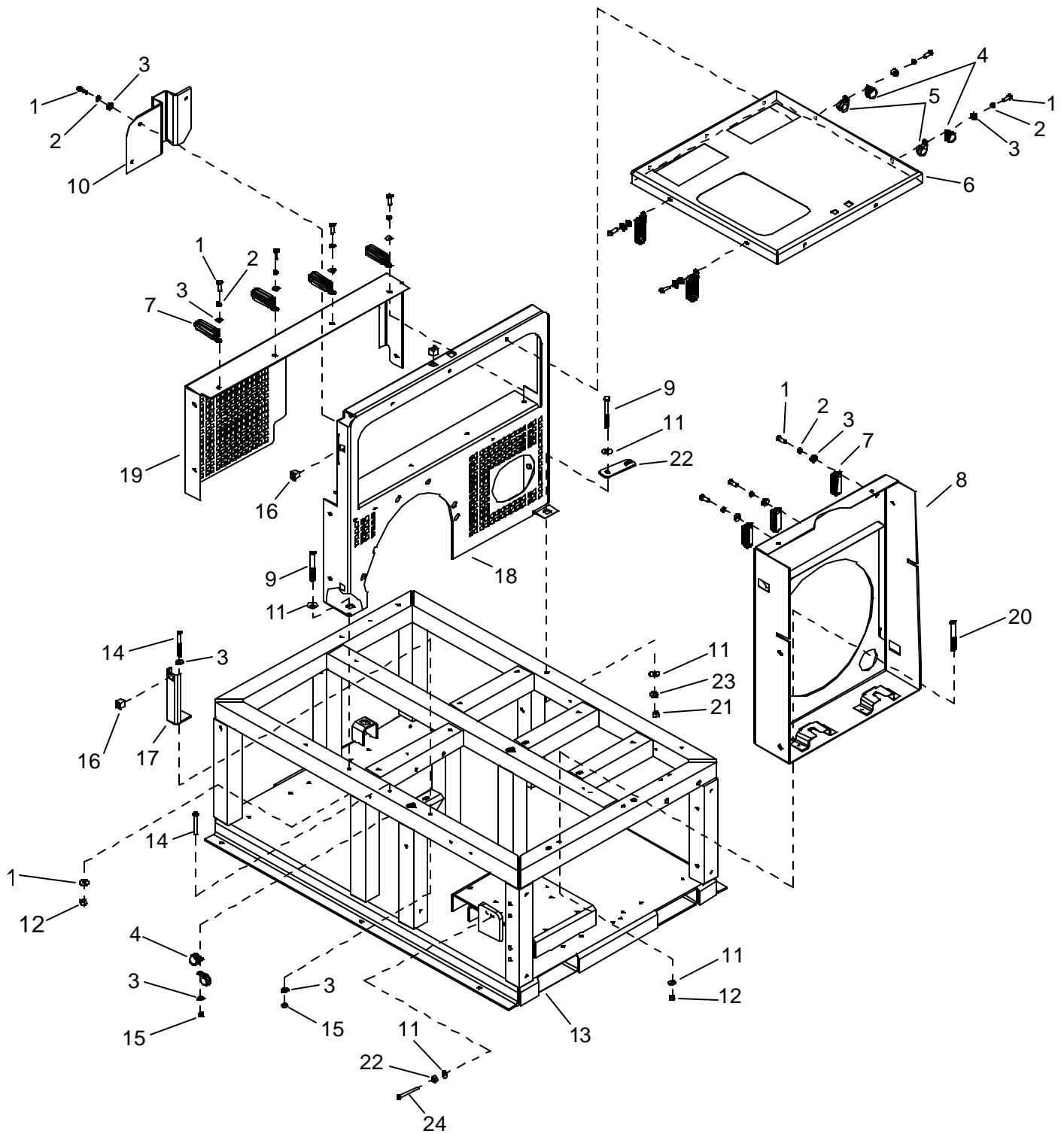

## FRAMEWORK

REF	PART NO.	QTY	DESCRIPTION	SERIAL NO. FROM	NOTES:
1	00-000078	22	SCR, 1/4-20 X 1" HXHD GRD8		
2	87162	22	WASHER, 1/4 SPLIT LOCK PLTD		
3	02-000066	24	FLATWASHER, 1/4		
4	03-000149	2	CLAMP, CABLE 1-1/4 ID 5/16 BLT		
5	80887	2	CLAMP, 7/8 DIA "P" CUSHIONED		
6	790763	1	PNL, CNTR HOOD BRKT, ZEEMS		
7	03-000266	9	CLMP, FUEL LINE 5/16 X 1/4B		
8	790764	1	ASSY, RAD BRKT		
9	70069	2	SCR, 3/8-16 X 3 HHCS GR5		
10	790767	1	ASSEMBLY, 04 FUEL PICKUP TUBE		
11	87171	5	WASHER, 3/8 FLAT		
12	57119	6	NUT, 3/8-16 HEX NYLOCK		
13	790793	1	ASSY, FRAME, EVRST/PEAK/ULTRA		
14	00-000286	2	SCR, CAP 1/4-20 X 2.75 HXHD		
15	57047	2	NUT, 1/4-20 HEX NYLOCK		
16	01-000259	9	RECPT, SNAPIN 1/4 TURNFAST		
17	790135	1	BRKT, LEFT HOOD		
18	790762	1	PNL, REAR ENGINE/HOOD MTG		
19	790010	1	PNL, BELT GUARD, REAR		
20	70824	2	SCR, 3/8-16 X 2.75 CARRIAGE PL		
21	57111	2	NUT, 3/8 HEX		
22	790811	1	PLT, CAT SUPPORT		
23	87163	1	WASHER, 3/8 SPLIT LOCK		



# FRAMEWORK

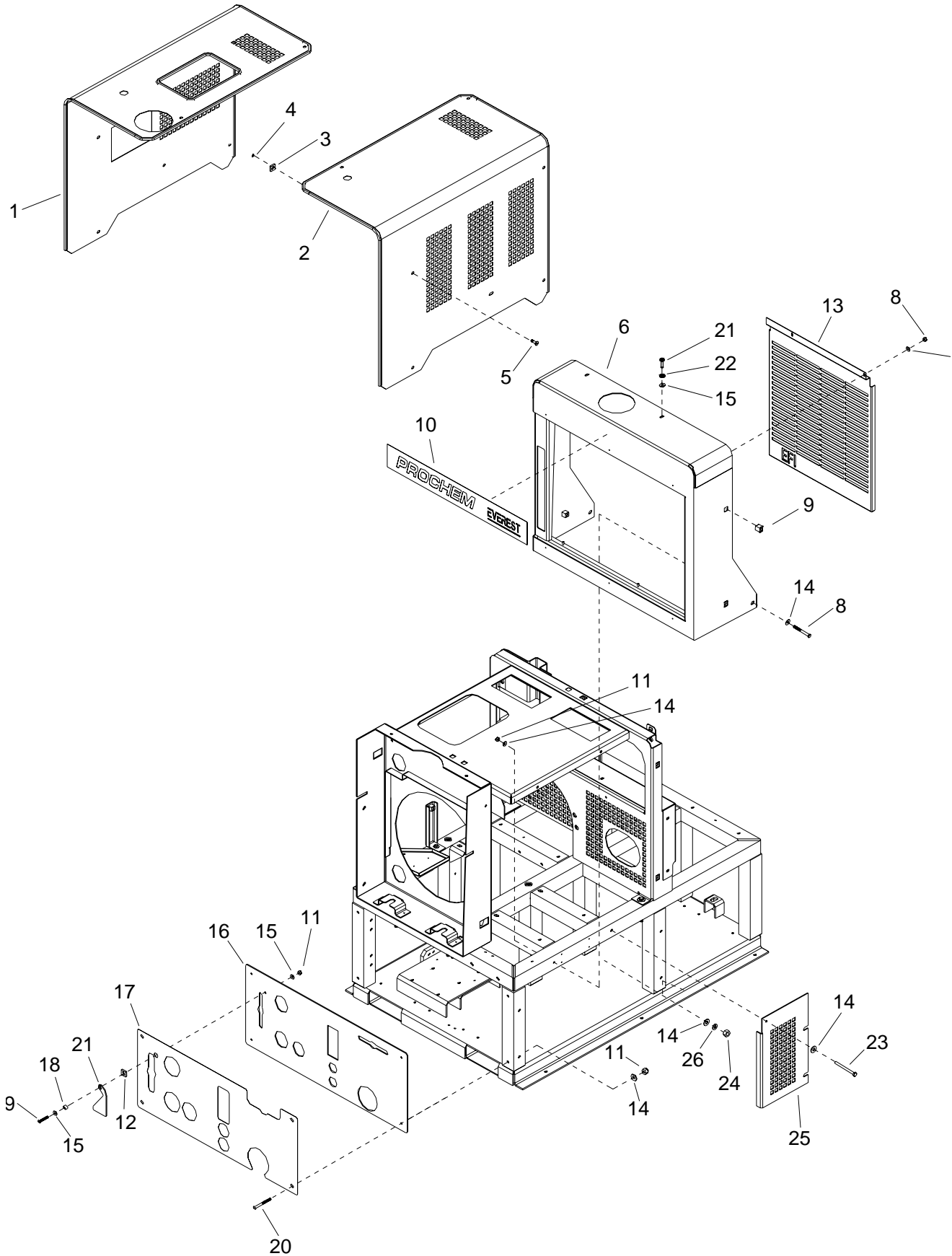

## FRAMEWORK

REF	PART NO.	QTY	DESCRIPTION	SERIAL NO. FROM	NOTES:
1	790817	1	ASSY, LEFT HOOD EFI		
2	790818	1	ASSY, RIGHT HOOD, EFI		
3	58-700023	16	PAD, 1/4 TURN FAST, .188 THK		
4	02-000268	16	SPLITRING, RETAIN, 1/4 TUR		
5	00-000272	16	STUD, 1/4 TURN FAST #85 OV		
6	790766	1	PNL, FR HD ASS, EVRST EFI		
7	87139	2	WASHER, 3/16 FLAT		
8	57090	2	NUT, 10-32 HEX NYLOCK SS		
9	01-000259	10	RECPT, SNAPIN 1/4 TURNFAST		
10A	500697	1	LABEL, FT HOOD		LP ONLY
10B	500698	1	LABEL, FT HOOD HP		HP ONLY
11	57047	5	NUT, 1/4-20 HEX NYLOCK		
12	58-700023	1	PAD, 1/4 TURN VIBR		
13	790883	1	PNL, GRILLE, EVEREST, EFI		
14	02-000066	4	FLATWASHER, 1/4		
15	87172	4	WASHER, 1/4 ID FLAT BLK		
16A	790867	1	PNL, LOWER FRONT, EFI LP		LP ONLY
16B	790866	1	PNL, LOWER FRONT EFI HP		HP ONLY
17A	790820	1	DEC, LWR FR PNL, LP EFI		LP ONLY
17B	790819	1	DEC, LWR FR PNL, HP EFI		HP ONLY
18	73698	1	SPACER, 0.50 X 0.28ID X 0.38L NYL		
19	70489	1	SCR, 1/4-20 X 1.0 BH BLK PLATE		
20	790465	4	SCR, 1/4-20 X 2.75 BHCS BLK		
21	790551	1	PLT, HIGH PRESSURE LCK		HP ONLY
22	80887	2	CLAMP, 7/8" DIA "P" CUSHIONED		
23	00-000286	1	SCR, CAP 1/4-20 X 2.75 HXHD		
24	57006	1	NUT, 1/4-20 HEX		
25	790804	1	GUARD, CATALYST ZEEMS		
26	87162	1	WASHER, 1/4 SPLIT LOCK PLTD		

# SIDE PANEL, RIGHT

TO VACUUM RELIEF VALVE

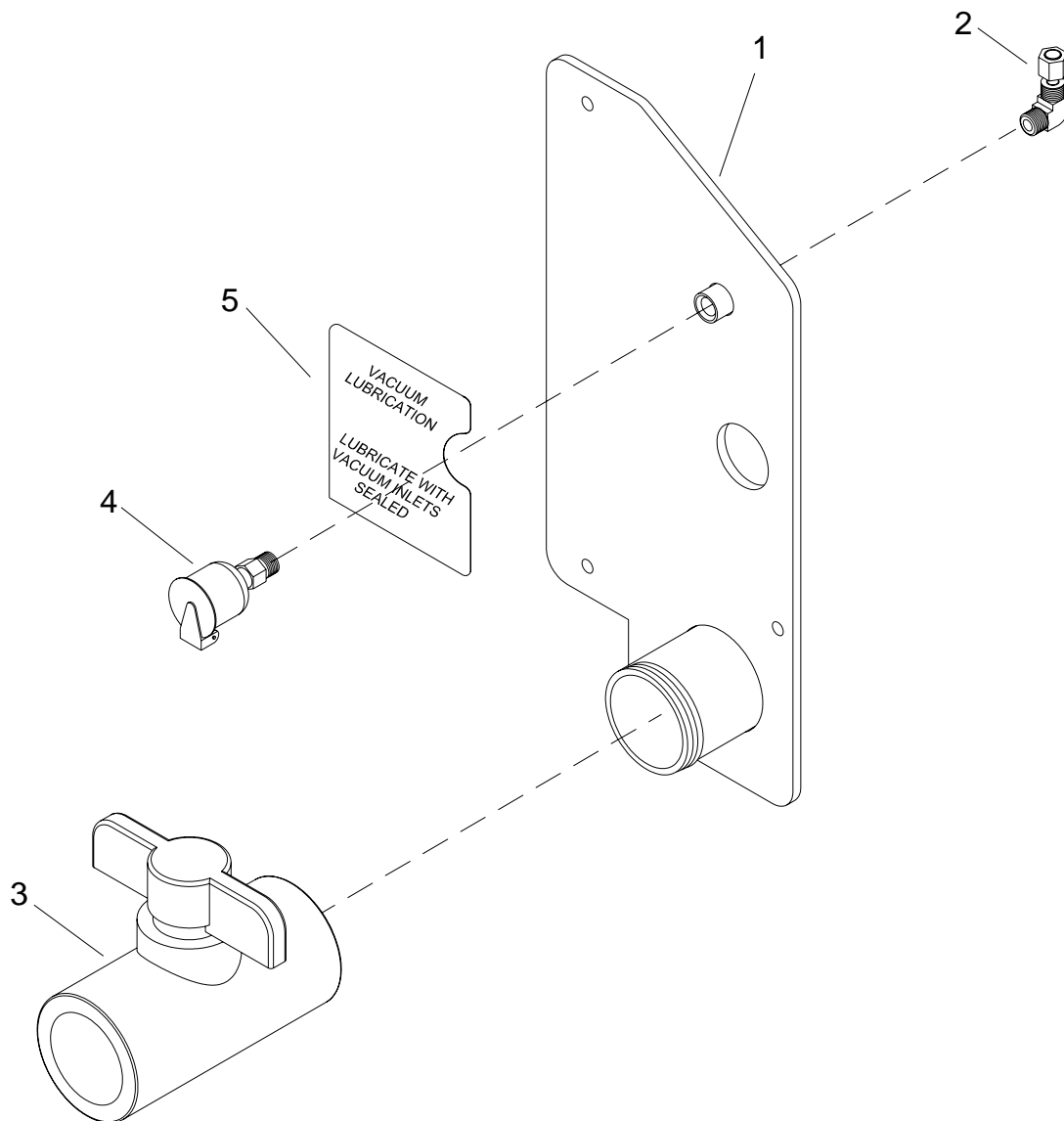

**SIDE PANEL, RIGHT**

REF	PART NO.	QTY	DESCRIPTION	SERIAL NO. FROM	NOTES:
1	05233	1	ASSY, RIGHT WING, CTK		
2	12-800099	1	ELL, 1/8P X 1/4 POLY BR		
3	11-800102	1	NIP, 3/8 HX BR		
4	19-800075	1	CUP. OIL FILL 1/8P		
5	500870	1	LABEL, RIGHT WING CTK		

# SIDE PANE, LEFT

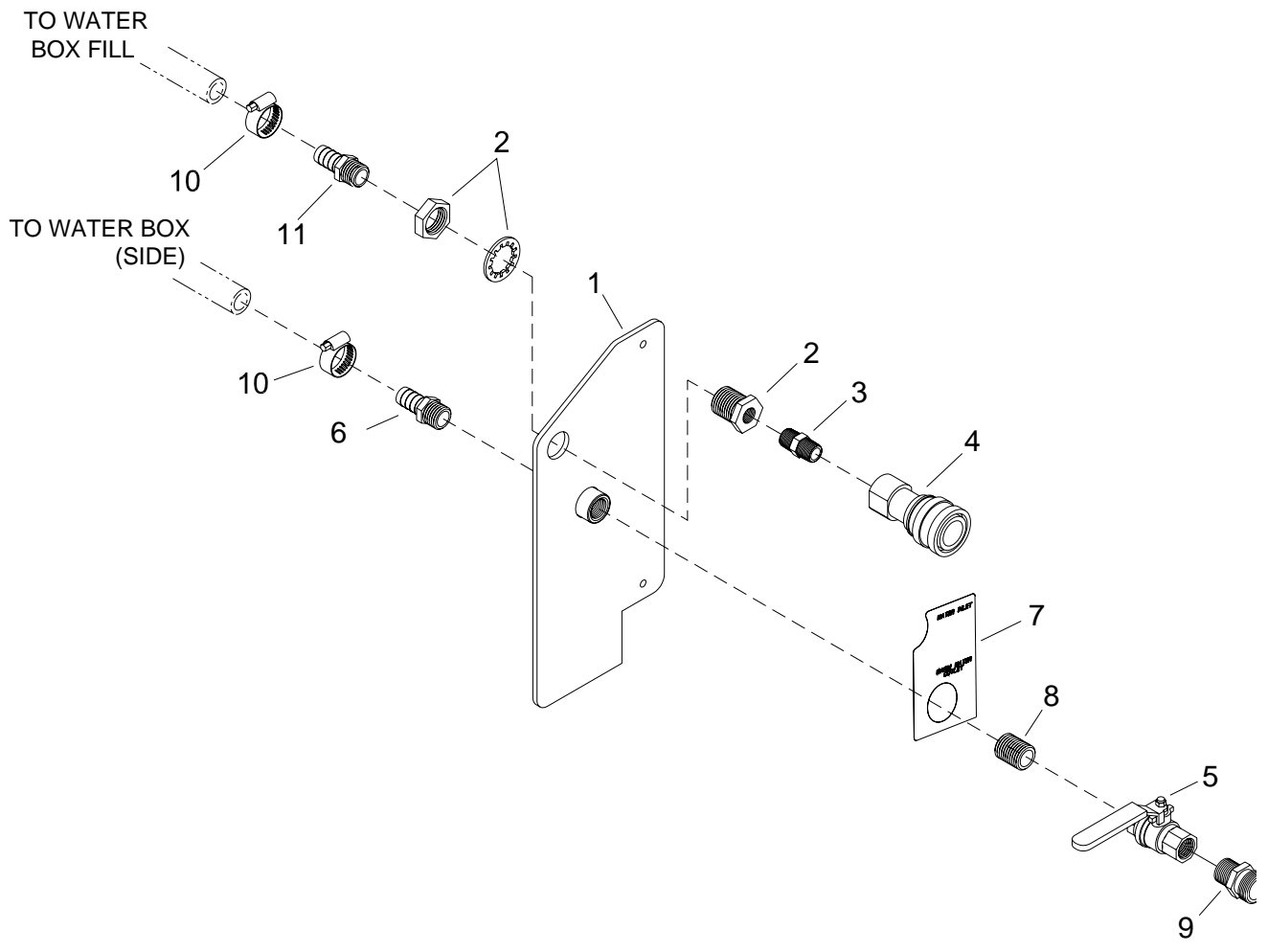

**SIDE PANEL, LEFT**

REF	PART NO.	QTY	DESCRIPTION	SERIAL NO. FROM	NOTES:
1	05234	1	ASSY, LEFT WING, CTK		
2	11-800437	1	ADPT, 3/8 BLKHD		
3	11-800102	1	NIP, 3/8 HX BR		
4	13-806008	1	DSC, 3/8F X 3/8FP		
5	15-808008	1	VLV, BALL 1/2FP BS		
6	12-800269	1	FTTG, BRB 1/2P X 5/8H BR		
7	500871	1	LABEL, LEFT WIND CTK		
8	11-800300	1	NIP, 1/2 X CL		
9	790506	1	ADAPTER, HOSE 1/2M X MGT		
10	03-000176	1	CLAMP, HOSE #16		
11	12-800345	1	FTTG, BRB 3/8P X 5/8H BR		

# CHEMICAL CONTROL PANEL

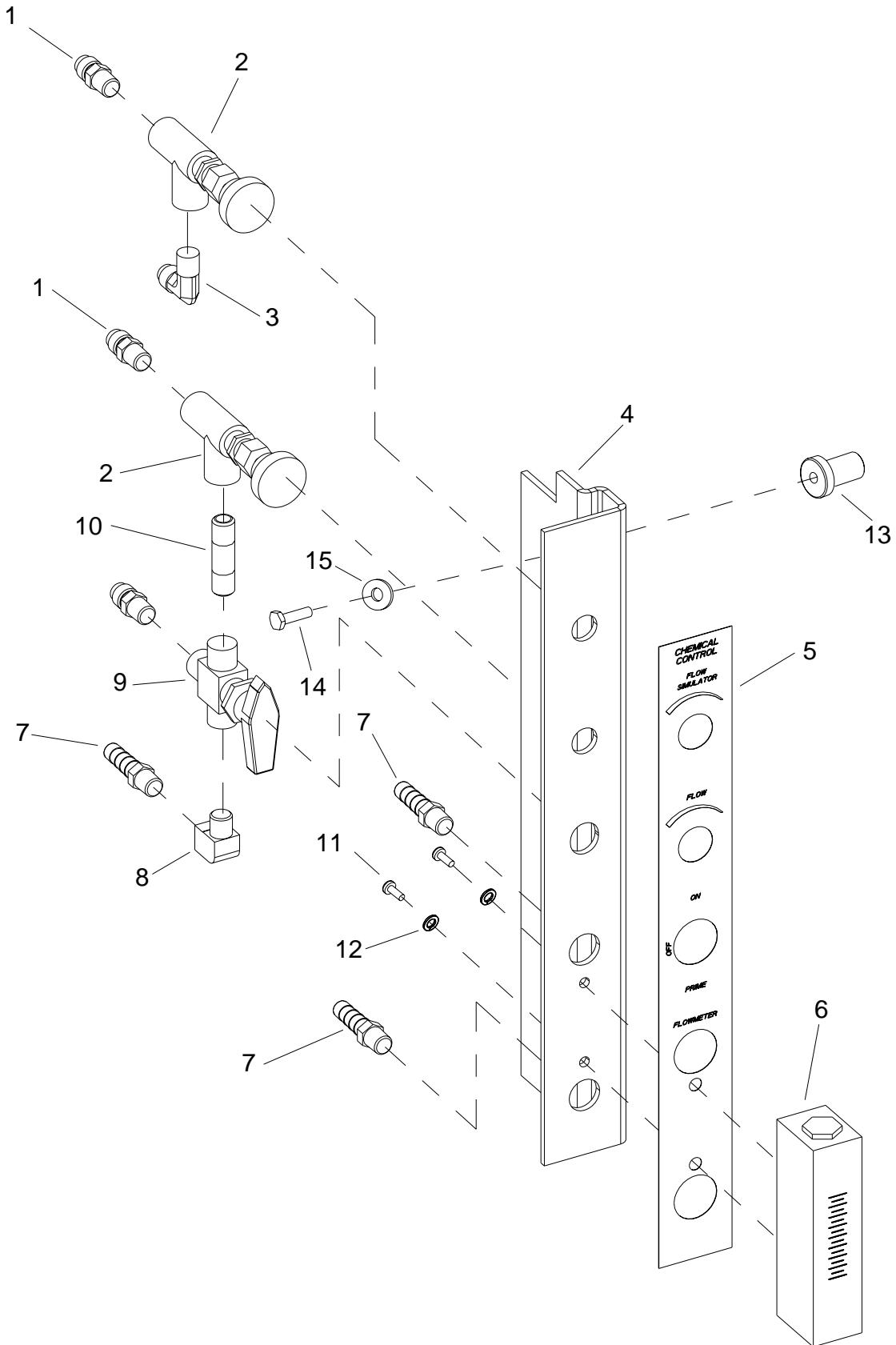

## CHEMICAL CONTROL PANEL

REF	PART NO.	QTY	DESCRIPTION	SERIAL NO. FROM	NOTES:
-	61384	-	ASSY, CHEM CONTRL PNL		COMPLETE
1	12-800065	3	CONN, 1/8P X 1/4T		
2	15-808106	2	VALVE, METER 1/8FP		
3	12-800040	1	ELL, 1/8P X 1/4T BR		
4	61397	1	PNL, CHEMICAL CONTROL		
5	500692	1	LABEL, CHEM CNTRL PN		
6	18-808513	1	FLOWMETER 1/8 FP		
7	12-800093	3	FTG, BRB 1/8P X 5/16H		
8	11-800014	1	ELL, STREET 1/8 BR		
9	15-808022	1	VALVE, 3-WAY BALL 1/8FP		
10	56032	1	NIPPLE, 1/8 CLOSE		
11	70162	2	SCR, 10-32 X 3/8 PPHMS SS		
12	87165	2	WASHER, #10 SPLIT LOCK		
13	790464	2	NUT, WELL 1/4-20 HD		
14	00-000078	2	SCR, 1/4-20 X 1" HXHD GRD8		
15	02-000066	2	FLATWASHER, 1/4		



# CONTROL PANEL-PP-PHP

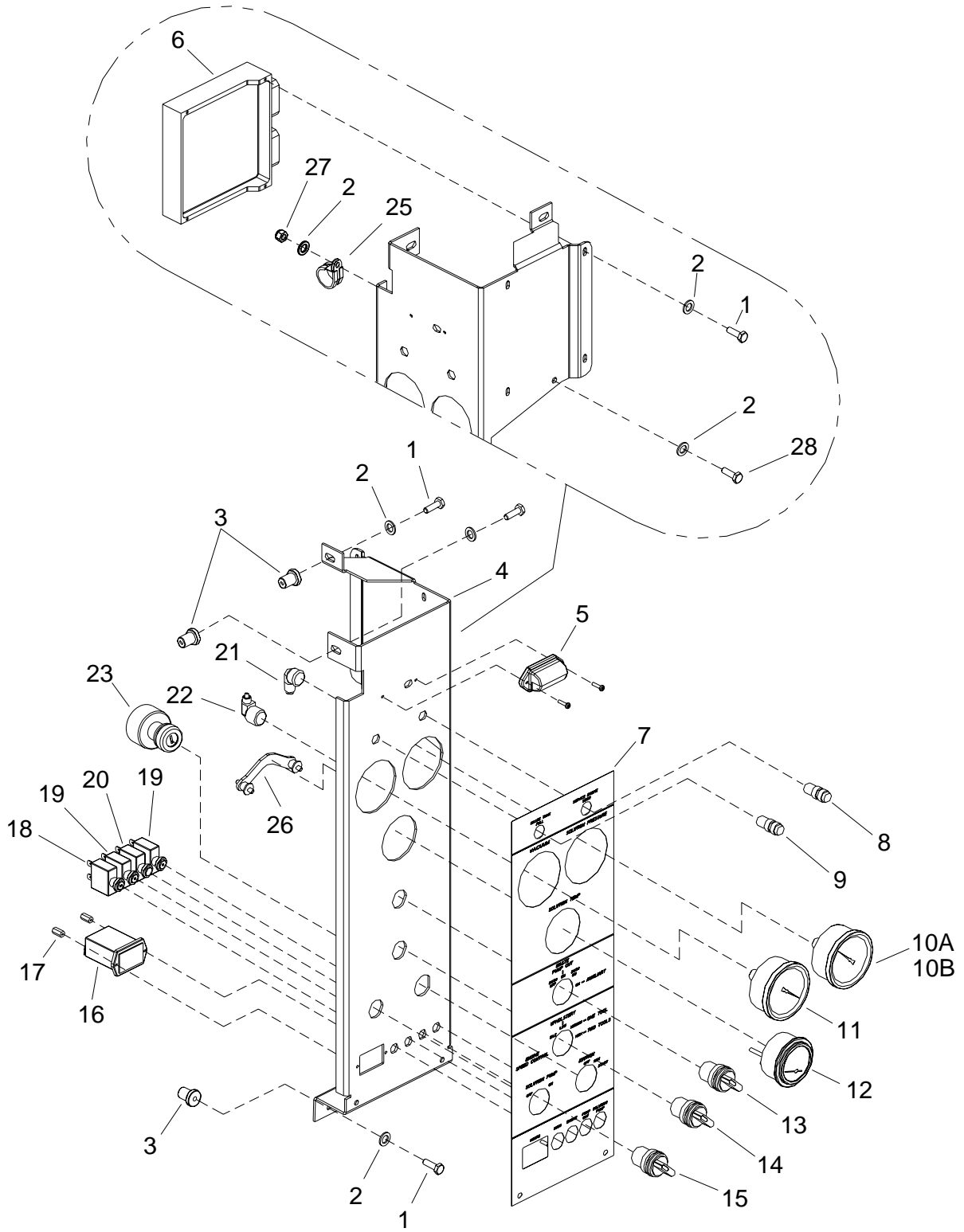

## CONTROL PANEL-PP-PPHP

REF	PART NO.	QTY	DESCRIPTION	SERIAL NO. FROM	NOTES:
-	790796	1	ASSY, INS PNL EVEREST EFI, LP		LP COMPLETE
-	790795	-	ASSY, INS PNL EVEREST EFI HP		HP COMPLETE
1	00-000078	2	SCR, 1/4-20 X 1" HXHD GRD8		
2	02-000066	4	FLATWASHER, 1/4		
3	790464	4	NUT, WELL 1/4-20 HD		
4	790768	1	PNL, INSTRUMENT, ZEEMS		
5	34-903026	1	LT, INST		
6	790788	1	ECU, NISSAN, A15, EFI		
7	790799	1	LBL, INS PANEL, ZEEMS		
8	790787	1	LIGHT, WARN, AMBER, IDEC		
9	51387	1	LIGHT, WARNING, IDEC AP2M		
10A	36225	1	GAUGE, 0-1500 PSI		LP ONLY
10B	36226	1	GAUGE, 0-4000 PSI		HP ONLY
11	36227	1	GAUGE, VACUUM 30" HG		
12	36229	1	GAUGE, TEMP, DATCON		
13	730202	1	SWITCH, 4-WAY		
14	790777	1	SWITCH, 4-WAY, SPEED CNTRL		
15	32-900205	1	SW, RTRY NON-ILLUM TM		
16	54092	1	METER, 0-60VDC HOUR		
17	73811	2	STANDOFF, 6-32 X 1/2 HEX NYL		
18	140625	1	BRKR, CIRCUIT 30A		
19	140624	2	BRKR, CIRCUIT, 15A		
20	33-900163	1	BREAKER, CIRC 20A		
21	12-800035	1	ELL, 1/4FP X 1/4T BR		
22	12-800101	1	ELL, 1/4FP X 1/4 POLY BR		
23	32-900201	1	SW, START W/KEY 3 POS TM		
24	57047	1	NUT, 1/4-20 HEX NYLOCK		
25	81270	1	CLAMP, 3/4 DIA CUSHION .406DIA		
26	140702	1	BRKT, WIKA MOUNTING		
27	57047	1	NUT, 1/4-20 HEX NYLOCK		
28	70270	1	SCR, 1/4-20 X 3/4 HHCS PLTD		

# ENGINE

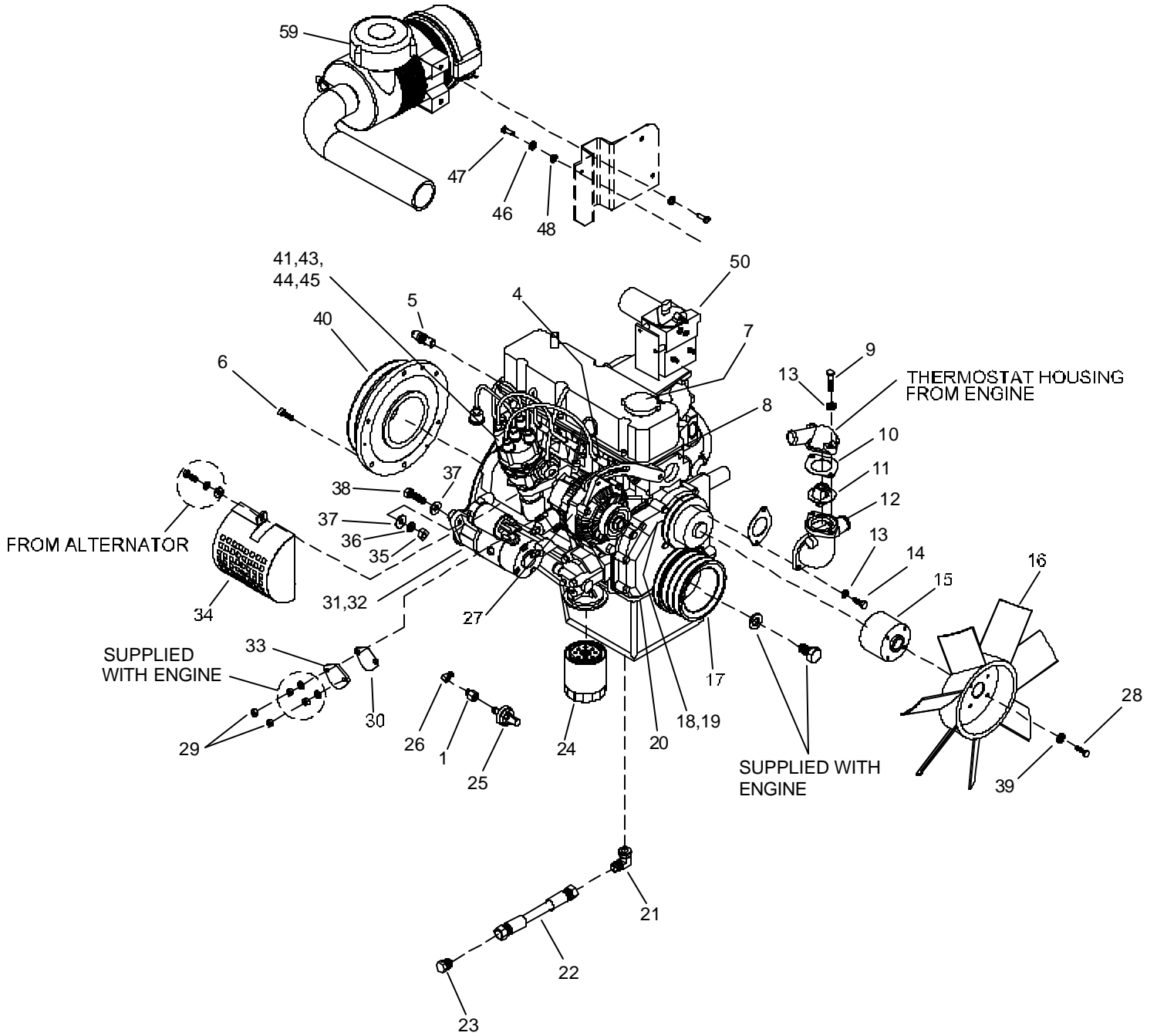

# ENGINE

REF	PART NO.	QTY	DESCRIPTION	SERIAL NO. FROM	NOTES:
	790798	-	ENG, A-15, ZEEMS		COMPLETE
1	04080	1	ADAPTER, #2 BSPT X 1/8 FNPT BR		
2	790586	1	HOSEBARB, #2 MBSPT X 5/16		
3	09-805632	1	HOSE FUEL 5/16 X 10"		
4	42-902148	4	NIS PLG, SPRTK#22401-M7714		
5	730299	1	ENGINE COOLANT SENSOR		
6	00-000428	6	SCR, CAP 8MM X 1.25 MM X 25MM		
7	42-902253	1	NIS BOLT, FAN#08120-64062		
8	42-902137	1	NIS BSKT, VLV CVR#13270-H		
9	70302	2	SCR, 5/16-18 X 1HHCS GR5PLT		
10	43-807067	2	GSKT, THERM-NIS A12		
11	35-900202	1	TERM, 195 DEG		
12	52-502020	1	ADPT, COOLNT OUTL		
13	87083	6	WASHER, 5/16 SPLIT LOCK PLTD		
14	70549	2	SCR, M8 X 25 HHCS GR8 PLTD		
15	790507	1	SPACER, FAN		
16	42-902155	1	NIS FAN#21060-N8560		
17	790826	1	PULLEY, 3 BELT EFI		
18	42-902349	1	NIS PMP, WTR#21010-K7700		
19	42-902350	1	NIS GSKT, WTR PMP#21014-H		
20	42-902134	1	NIS SET, PAN GSKT#11132-H		
21	12-800177	1	ELL, #6BSTX1/2T ZNC PL		
22	10-805315	1	HOSE, HP 3/8X13" (1/2FT BS)		
23	12-800062	1	PLUG, 1/2T		
24	42-902139	1	NIS FLT, OIL#15208-55Y00		
25	730296	1	SW, OIL PRESS		
26	31090	1	ELBOW, #2 BSPT 90DEG ST BRASS		
27	42-902188	1	NIS ALT (50AMP) #23100-H7711		
28	70763	4	SCR, M6 X 40 MMPLTD		
29	57054	2	NUT, M8		
30	42-902152	1	NIS GSKT, FUEL PMP D24076		
31	730298	1	NIS START#23300-K4915		
32	42-902147	1	NIS, SOLEN, START#23343-B5		
33	50-501915	1	PL, FUEL PMP CVR		
34	56-501740	1	CVR, ALT		
35	57114	2	NUT, 7/16-14 HEX		
36	87176	2	WASHER, 7/16 SPLIT LOCK PLTD		
37	87171	4	WASHER, .531 ID X 1.25 X 1 FLT PLT		
38	00-000222	2	SCR, CAP 7/16-14 X 1.5 HX		
39	87085	4	WASHER, M6 SPLIT LOCK DIN127B		
40	52-502072	1	PULLEY, ENGINE A15 (BLOWER DR)		
41	42-902352	1	NIS UNIT, TRANS#22020-G5110		
42	42-902272	1	NIS ROTOR#22157-05M02		
43	42-902153	1	NIS SEAL, DISTR. CAP#22185-23615		
44	42-902271	1	NIS CAP, DISTR#2216278A10		
45	42-902196	1	NIS DIST#22100-G5110		
46	87162	2	WASHER, 1/4 SPLIT LOCK PLTD		
47	00-000078	3	SCR, 1/4-20 X 1" HXHD GRD8		
48	02-000066	3	FLATWASHER, 1/4		
49	790780	1	ASMBLY, FLTR, AIR, ZEEMS		
50	78566	1	THROTTLE BODY ASSY, W/O ECU		
51	790300	1	SENSOR, AIR EMPEATURE		NOT SHOWN
52	730301	1	SENSOR, MAP		NOT SHOWN
53	35273	1	GASKET KIT, MANIFOLD		NOT SHOWN
54	790779	1	FLT, AIR, ELMNT, ZEEMS		NOT SHOWN (FOR ITEM 50)

# ENGINE

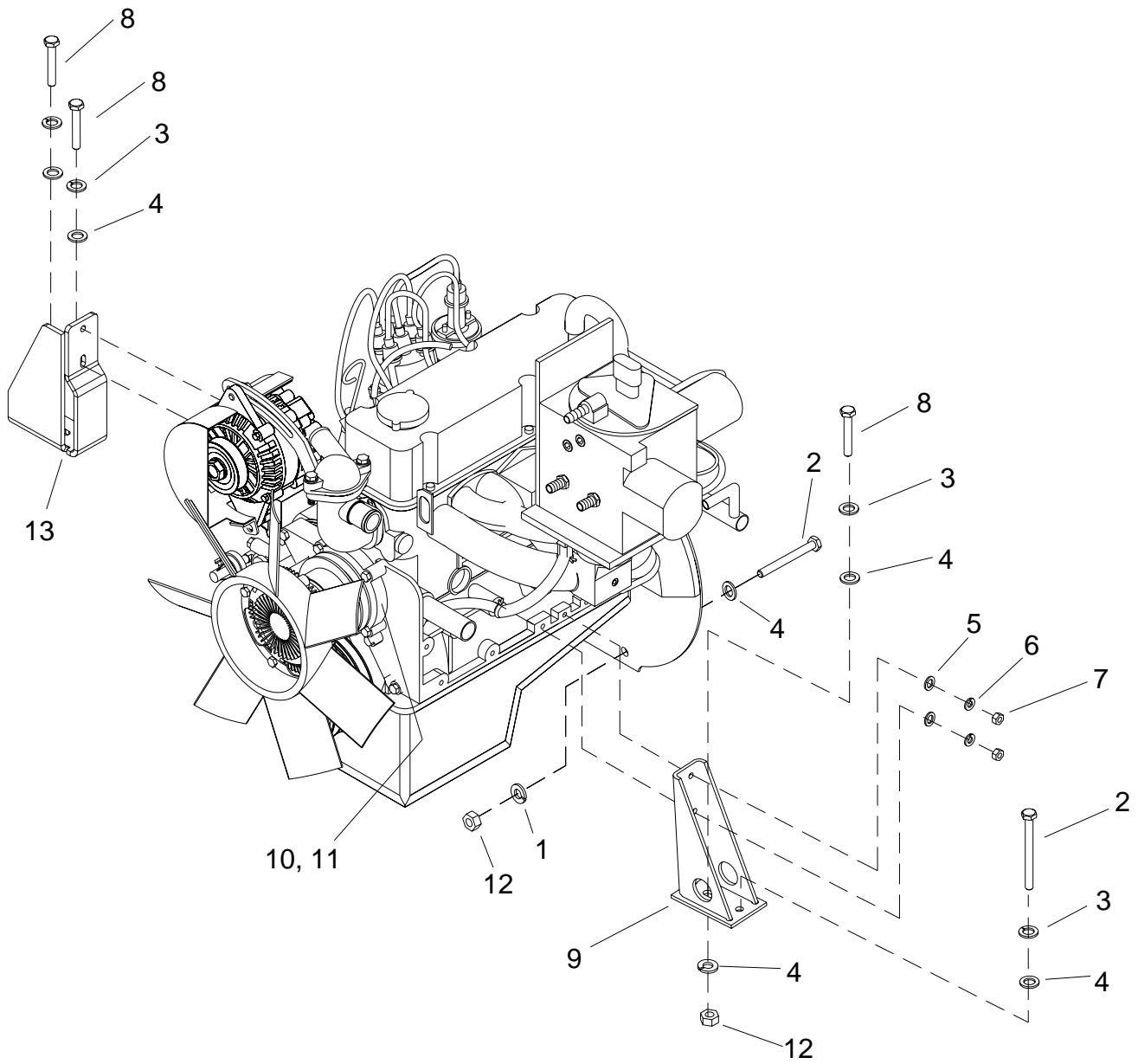

**ENGINE**

REF	PART NO.	QTY	DESCRIPTION	SERIAL NO. FROM	NOTES:
1	87168	8	WASHER, M10 SPLIT LOCK PLTD		
2	70069	3	SCR, 3/8-16 X 3 HHCS GR5		
3	87163	4	WASHER, 3/8 SPLIT LOCK PLTD		
4	87171	10	WASHER, 3/8 FLAT		
5	02-000143	4	WASHER, 5/16 FLAT PLTD		
6	87083	4	WASHER 5/16 SPLIT LOCK PLTD		
7	57054	4	NUT, M8		
8	70377	3	SCR, 3/8-16 X 1.25 HHCS SS		
9	790408	2	MOUNT, ENGINE		
10	42-902345	1	NIS PMP, WTR#21010-K7700		
11	42-602350	1	NIS GSKT, WTR PMP #2104-H		
12	57119	4	NUT, 3/8-16 HEX NYLOCK		
13	790912	1	MT, LEFT ENGINE		

# ENGINE

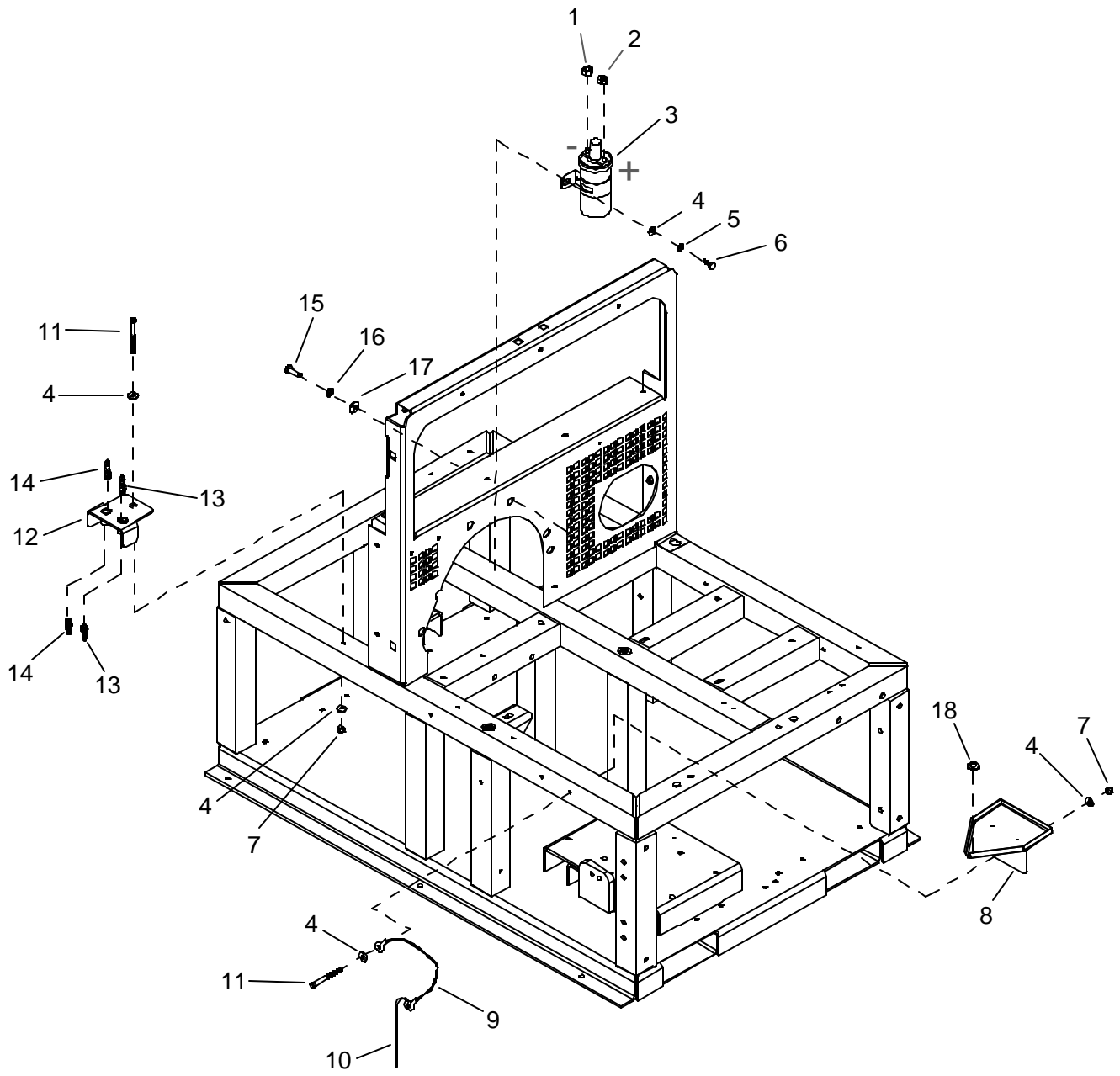

**ENGINE**

REF	PART NO.	QTY	DESCRIPTION	SERIAL NO. FROM	NOTES:
1	57086	1	NUT, M5		
2	57053	1	NUT, M6 HEX ZINC PLATED		
3	42-902144	1	NIS COIL#22433-52A60		
4	02-000066	7	FLATWASHER, 1/4		
5	87162	2	WASHER, 1/4 SPLIT LOCK PLTD		
6	70270	2	SCR, 1/4-20 X 3/4 HHCS PLTD		
7	57047	3	NUT, 1/4-20 HEX NYLOCK		
8	43-807504	1	GROM, 1/4IDX3/8OD		
9	64-950383	1	CABL, RETAIN VAC PLG 800		
10	790487	1	DIPSTICK, CAT PUMP OIL 5CP		
11	00-000286	3	SCR, CAP 1/4-20 X 2.75 HXHD		
12	790806	1	BRKT, FUEL ZEEMS		
13	12-800092	2	FTTG, BRB 1/4 X 5/16H BR		
14	40014	2	HOSEBARB, 1/4MPT X 3/8 DL		
15	70549	4	SCR, M8 X 25 HHCS GR8 PLTD		
16	87083	4	WASHER, M10 X 30 PLTD		
17	02-000143	4	WASHER, 5/16 FLAT PLTD		
18	790115	1	BRKT, OIL DRAINS		



# COOLANT SYSTEM

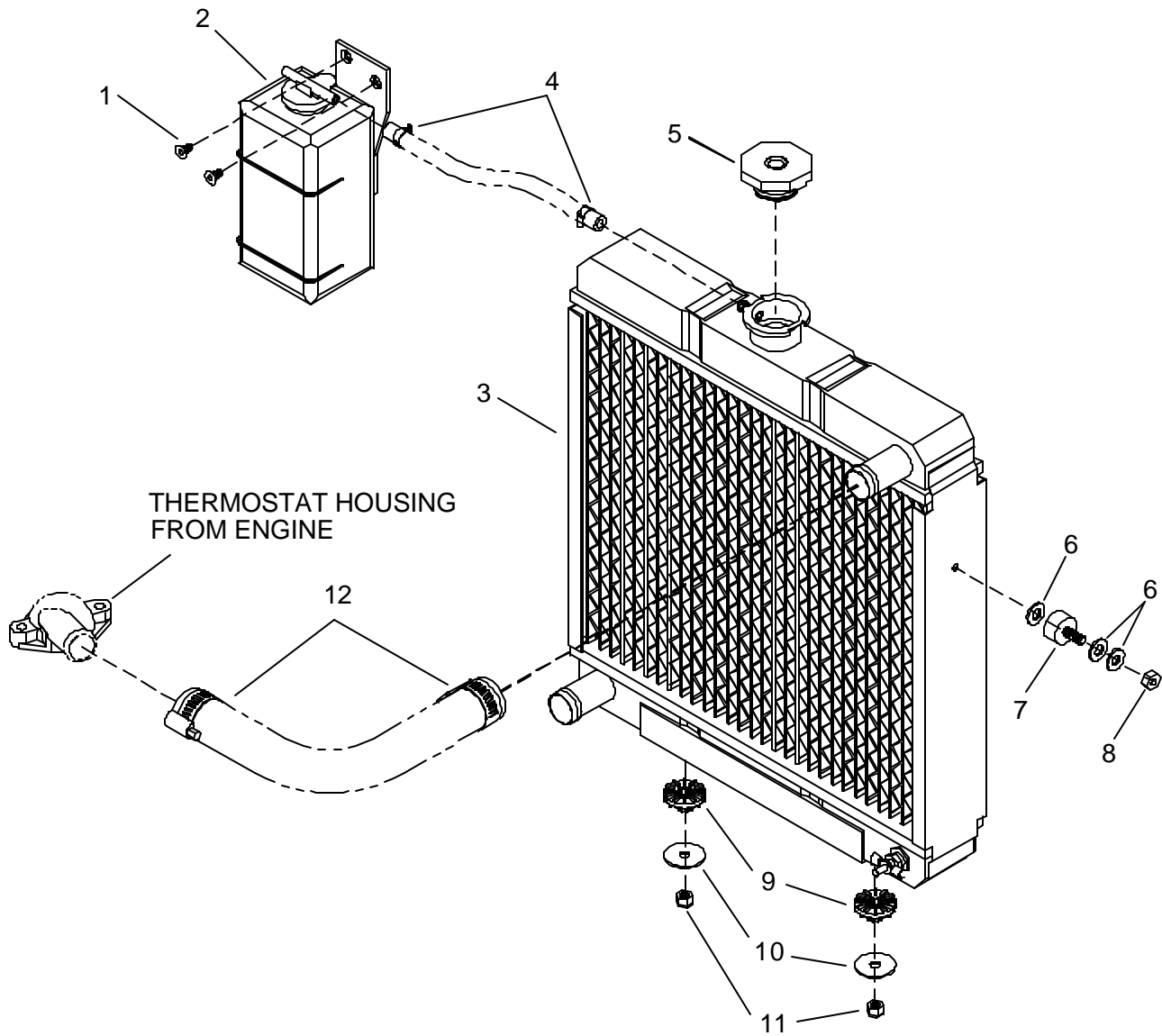

## COOLANT SYSTEM

REF	PART NO.	QTY	DESCRIPTION	SERIAL NO. FROM	NOTES:
1	00-000216	2	SCR, CAP 1/4-20 X 1/2 FLTSO		
2	140642	1	KBT BTL, OVRFL #19059-70		
3	790429	1	RADIATOR		
4	03-000065	2	CLAMP, HOSE #4 SST		
5	49-802010	1	CAP, RAD, STANT AGX2643-01		
6	02-000143	6	FLATWASHER, 5/16		
7	52-502038	2	MT, RAD		
8	57113	2	NUT, 5/16-18 HEX NYLOCK		
9	04-000296	2	FLEX, FINGER (BUSH)		
10	50-501761	2	WASHER, RAD		
11	57285	2	NUT, 5/16-18 NYLOCK THIN SS		
12	03-000248	2	CLMP, HOSE #16 1-1/2 MIN 1-3/4		

# VACUUM BLOWER

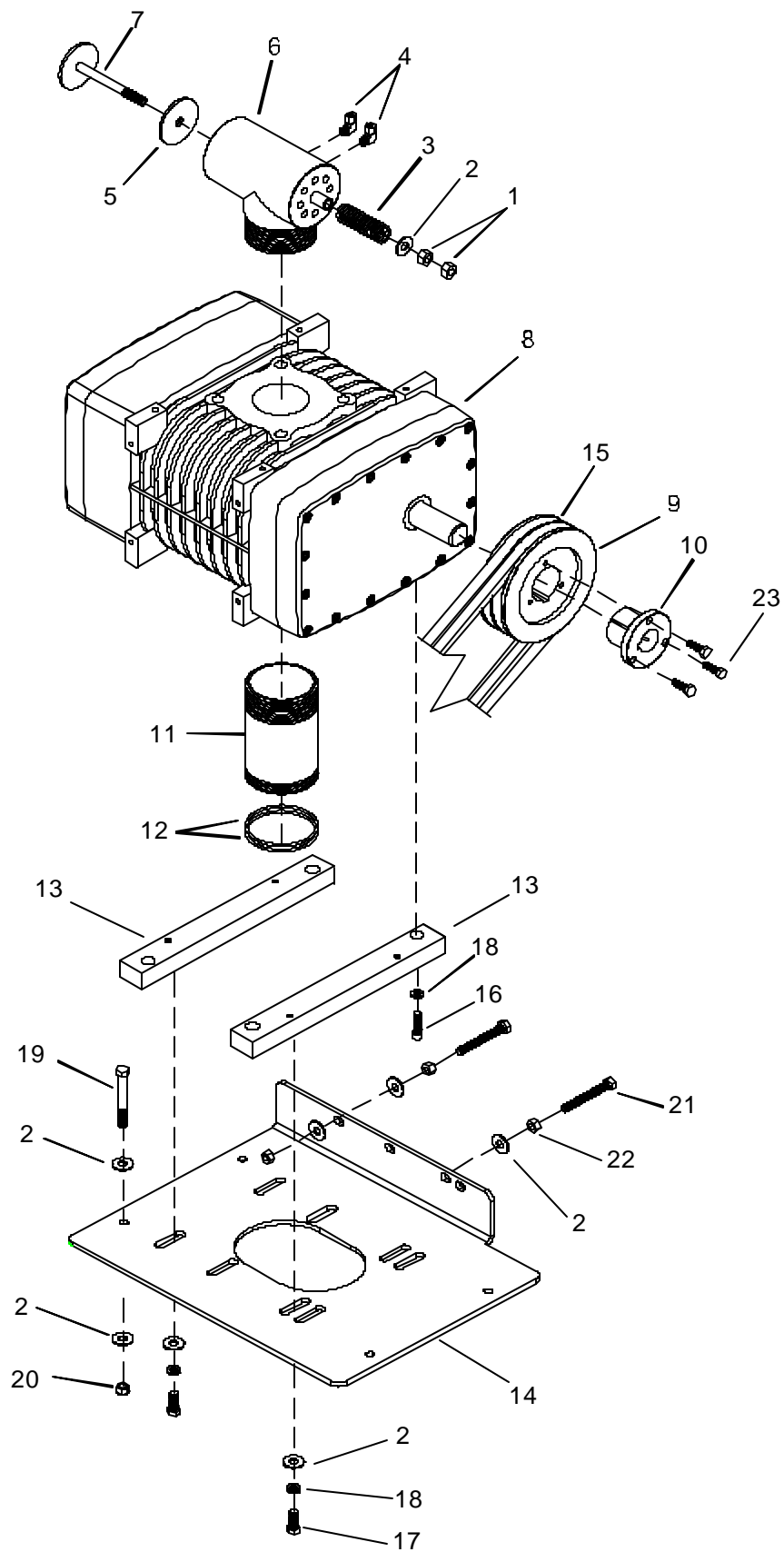

## VACUUM BLOWER

REF	PART NO.	QTY	DESCRIPTION	SERIAL NO. FROM	NOTES:
1	57114	2	NUT, 7/16-14 HEX		
2	87171	16	WASHER, 3/8 FLAT		
3	04-000091	1	SPRING, VAC REL VLV		
4	12-800099	2	ELL, 1/8P X 1/4 POLY BR		
5	43-807106	1	DIAPH, VAC REL VLV		
6	05239	1	VAC RELIEF W/ADAPTER		
7	56-501994	1	STM-VAC REL VLV		
8	140611	1	BLWR, TRI-FLOW		
9	790842	1	PULLEY, BLOWER 2TB52		
10	790444	1	HUB, P1 X 1-1/4		
11	52-502071	1	NIPPLE, VAC OUTL TRI-FLOW		
12	43-810104	2	O-RING, 3-1/4 X 3-1/2 OD		
13	790443	2	SPACER, BLOWER		
14	790442	1	PLT, BLOWER ADJUST		
15	44-802319	2	BELT, BX46 GOODYEAR MATCH		
16	790467	4	SCR, 5/16-18 X 1.25 SHCS		
17	70377	4	SCR, 3/8-16 X 1.25 HHCS BR5PLT		
18	87163	8	WASHER, 3/8 SPLIT LOCK		
19	70069	4	SCR, 3-8-16 X 3 HHCS BR5		
20	57119	4	NUT, 3/8-16 HEX NYLOCK		
21	00-000336	2	SCR, CAP 3/8-16 X 3 ALL THD		
22	57111	3	NUT, 3/8-16 HEX		
23	00-000340	3	SCR, MACH 5/16-18 X 1" GR 8		

# WATER PUMP-PP

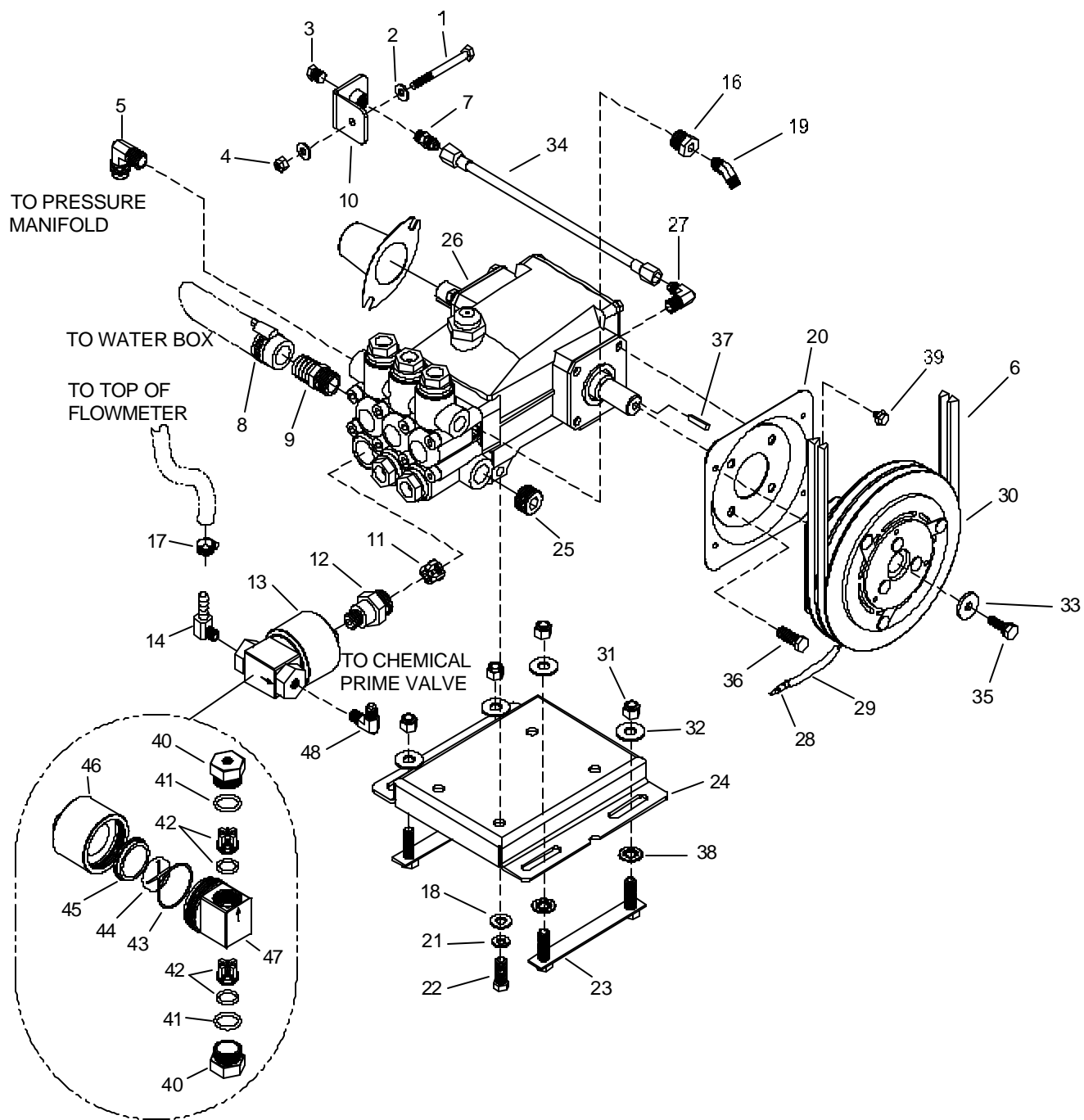

## WATER PUMP-PP

REF	PART NO.	QTY	DESCRIPTION	SERIAL NO. FROM	NOTES:
1	00-000286	1	SCR, CAP 1/4-20 X 2.75 HXHD		
2	02-000066	1	FLATWASHER, 1/4		
3	11-800101	1	PLUG, 1/8P		
4	87245	1	NUT, 1/4-20 HEX NYLOCK SS		
5	12-800225	1	ELL, 3/8P X 1/2T SST		
6	790446	2	BELT, NAPA A41		
7	12-800065	1	CONN, 1/8P X 1/4T		
8	03-000113	2	CLAMP, HOSE #12 SST		
9	12-800278	1	FTTG, BRB 1/2P X 3/4H BR		
10	790434	1	BRKT, 1/8 ALUM COUPLER		
11	52-809123	1	RETAIN, VALVE SPRING		
12	790317	1	ADAPTER, CEHM PMP (5CP3120)		
13	41-809158	1	PUMP, CHEM (O-RING) SS		
14	790605	1	EL, 90DEG 1/8 X 5/16HB		
15	OPEN				
16	11-800118	1	BUSH, 3/8X1/8 BR		
17	03-000065	2	CLAMP, HOSE #4 SST		
18	02-000143	4	WASHER, 5/16 FLAT PLTD		
19	12-800261	1	ELL, 1/8P X 1/4T 45 DEG		
20	140646	1	BRKT, CLTCH, WTR PMP, 2 GRV		
21	87083	4	WASHER, 5/16 SPLIT LOCK PLTD		
22	70262	4	SCR, M8 X 20 HHMS PLTD		
23	790436	2	STRAP, WTR PMP HOLDDOWN		
24	790900	1	PNL, WTR PMP BRKT, EFI		
25	11-800069	1	PLUG, 1/2 SOCHD BR		
26	790435	1	PUMP, WATER 5CP CAT		
27	12-800031	1	ELL, 1/4P X 1/4T BR		
28	31-900185	1	CONN, BULLET M (.156)		
29	51372	1	LOOM, 1/4, HIGH TEMP 10"		
30	790398	1	CLUTCH, ELEC WTR PMP		
31	57119	4	NUT, 3/8-16 HEX NYLOCK		
32	87171	4	WASHER, 3/8 FLAT		
33	87240	1	WASHER, .328ID X 1.00 OD X .119, ZNC		
34	10-805288	1	HOSE, 3/16 X 17"		
35	140644	1	BLT, 5/16-18 X 1, SOC, ZNC		
36	70807	4	BLT, 8MM X 14MM, SER FLNG, PH		
37	48098	1	KEY, .25 X .25 X 1, CAT WTR PMP		
38	57302	4	NUT, 3/8 PUSH PLATE		
39	140645	4	SCR, 1/4-20 X 3/8, SER FLNG		
40	16-808237	2	CAP, CHK VALVE CHM. PUMP		
41	43-810079	2	O-RING, 7/8 ID X 1-1/16OD		
42	42-809265	2	CHECK VALVE, CHEM PUMP		
43	43-810105	1	O-RING, 1-5/8OD X 1-3/4 OD/40D VITON		
44	42-809264	1	DISK, CHEM PUMP		
45	42-809047	1	DIAPHRAGM, CHEM PUMP		
46	52-502053	1	CVR, CHEM PUMP		
47	52-502052	1	BDY, CHEM PMP		
48	12-800040	1	ELL, 1/8P X 1/4T BR		

# WATER PUMP-PPHP

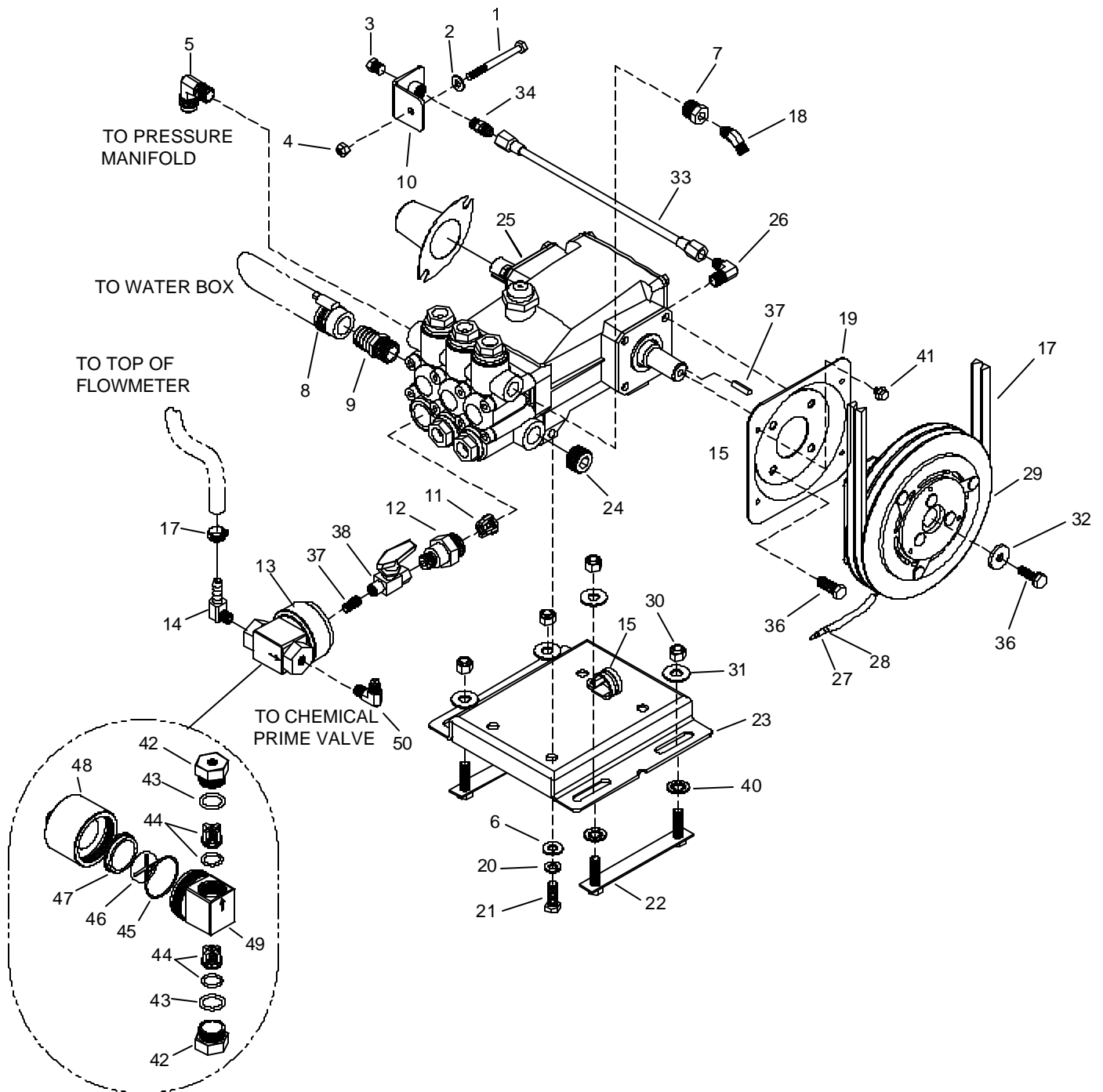

## WATER PUMP-PPHP

REF	PART NO.	QTY	DESCRIPTION	SERIAL NO. FROM	NOTES:
1	00-000286	1	SCR, CAP 1/4-20 X 2.75 HXHD		
2	02-000066	1	FLATWASHER, 1/4		
3	11-800101	1	PLUG, 1/8P		
4	57145	1	NUT, 1/4-20 HEX NYLOCK SS		
5	12-800446	1	ELL, 3/8P X 1/2T SST		
6	02-000143	4	WASHER, 5/16 FLAT PLTD		
7	11-800118	1	BUSH, 3/8X1/8 BR		
8	03-000113	2	CLAMP, HOSE #12 SST		
9	12-800278	1	FTTG, BRB 1/2P X 3/4H BR		
10	790434	1	BRKT, 1/8 ALUM COUPLER		
11	52-809123	1	RETAIN, VALVE SPRING		
12	790317	1	ADAPTER, CHEM PMP (5CP3120)		
13	41-809158	1	PUMP, CHEM SS		
14	790605	1	EL, 90DEG 1/8 X 5/16HB		
15	03-000249	1	CLMP, CABL 1/4ID 3/8BLT		
16	03-000065	2	CLAMP, HOSE #4 SST		
17	790446	2	BELT, NAPA A41		
18	12-800261	1	ELL, 1/8P X 1/4T 45 DEG		
19	140646	4	BRKT, CLTCH, WTR PMP, 2GRV		
20	87083	4	WASHER, M20 ID X MM		
21	70262	4	SCR, M8 X 20 HHMS PLTD		
22	790436	2	STRAP, WTR PMP HOLDDOWN		
23	790900	1	PNL, WTR PMP BRKT, EFI		
24	11-800069	1	PLUG, 1/2 SOCHD BR		
25	790435	1	PUMP, WATER 5CP CAT		
26	12-800031	1	ELL, 1/4P X 1/4T BR		
27	31-900185	1	CONN, BULLET M (.156)		
28	51372	1	LOOM, 1/4, HIGH TEMP 10"		
29	790398	1	CLUTCH, ELEC WTR PMP		
30	57119	4	NUT, 3/8-16 HEX NYLOCK		
31	87171	4	WASHER, 3/8 FLAT		
32	87240	1	WASHER, .328ID X 1.00 OD X .119, ZNC		
33	10-805288	1	HOSE, 3/16 X 17"		
34	12-800065	1	CONN, 1/8P X 1/4T		
35	70807	4	BLT, 8MM X 14MM, SER FLNG, PH		
36	140644	1	BLT, 5/16-18 X 1, SOC, ZNC		
37	48098	1	KEY, .25 X .25 X 1, CAT WTR PMP		
38	15-808169	1	VALVE, BALL 6000 PSI		
39	11-800369	1	NIP, 1/4 X CL SST		
40	57302	4	NUT, 3/8 PUSH PLATE		
41	140645	4	SCR, 1/4-20 X 3/8, SER FLNG		
42	16-808237	2	CAP, CHK VALVE CHEM. PUMP		
43	43-810079	2	O-RING, 7/8 ID X 1-1/16 OD		
44	42-809265	2	CHECK VALVE, CHEM PUMP		
45	43-810105	1	O-RING, 1-5/8ID X 1-3/4OD VITON		
46	42-809264	1	DISK, CHEM PUMP		
47	42-809047	1	DIAPHRAGM, CHEM PUMP		
48	52-502053	1	CVR, CHEM PMP		
49	52-502052	1	BDY, CHEM PMP		
50	12-800040	1	ELL, 1/8P X 1/4T BR		



# WATER PUMP-PP-PPHP

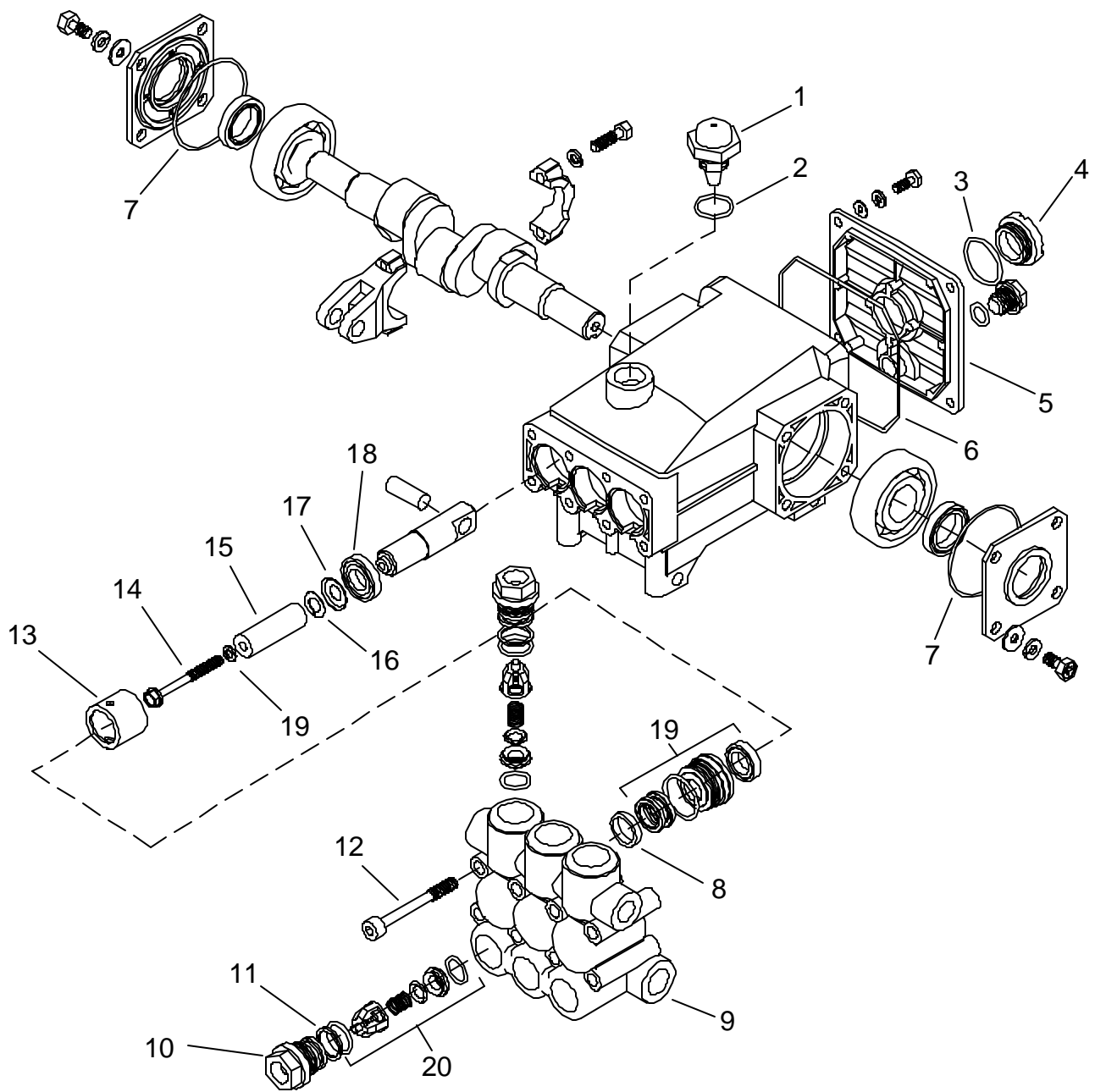

**WATER PUMP-PP-PPHP**

REF	PART NO.	QTY	DESCRIPTION	SERIAL NO. FROM	NOTES:
1	42-809393	1	CAT#46798 CAP, OIL FILTER		
2	42-809239	1	O-RING, OIL CUP FILL CAP		
3	43-807063	1	GASKET, OIL GAUGE		
4	42-902380	1	GAUGE, OIL LEVEL		
5	42-809392	1	CAT#46940 CVR, CRANKCASE		
6	42-809391	1	CAT#14044 O-RING, CRANKCASE		
7	42-809394	1	O-RING, BEARING CVR		
8	42-809388	1	CAT#46618 ADAPT, MALE		
9	42-809387	1	CAT#46886 MNFLD, HEAD 5CP		
10	42-809320	1	CAT#45900 PLG, VLV 5CP		
11	42-809386	1	CAT#48365 RNG, BK-UP VLV		
12	42-809385	4	CAT#87872 BLT, MNFLD HEAD		
13	42-809384	1	CAT#46749 RETAIN, SEAL 5C		
14	42-809383	1	CAT#48201 RETAIN, PLNGR		
15	42-809382	1	CAT#46884 PLNGR 5CP		
16	42-809249	1	WASHER, KEYHOLE M18		
17	42-809381	1	SLINGER, BARRIER		
18	42-809380	1	CAT#46838 SEAL, OIL CRANK		
19	790508	1	KIT, PISTON SEAL HI TEMP		
20	42-809397	1	CAT#46886 MNFLD, HEAD 5CP		
-	05-008016	1	OIL, CAT-WTR PMP		

# VAC/HEAT EXCHANGER WITH SILENCER

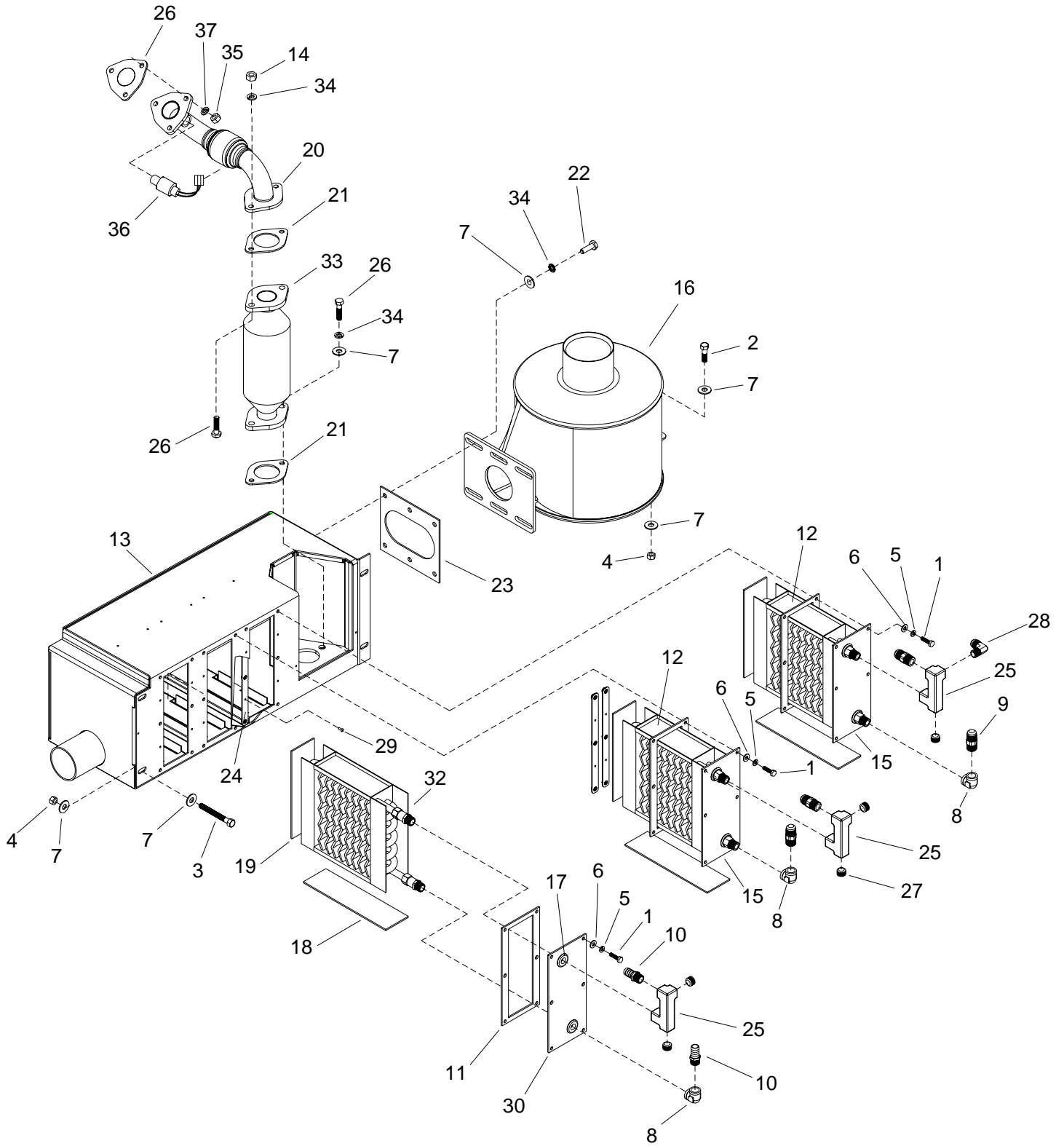

## VAC/HEAT EXCHANGER WITH SILENCER

REF	PART NO.	QTY	DESCRIPTION	SERIAL NO. FROM	NOTES:
1	00-000078	22	SCR, 1/4-20 X 1" HXHD GRD8		
2	70377	1	SCR, 3/8-16 X 1.25 HHCS GR5PLT		
3	70069	4	SCR, 3/8-16 x 3 HHCS GR5		
4	57119	11	NUT, 3/8-16 HEX NYLOCK		
5	87162	22	WASHER, 1/4-20 SPLIT LOCK PLTD		
6	02-000066	22	FLATWASHER, 1/4		
7	87171	14	WASHER, 3/8 FLAT		
8	11-800276	3	ELL, 3/8 BR		
9	12-800282	4	CONN, 3/8P x 1/2T BR		
10	12-800345	2	FTTG, BRB 3/8P x 5/8H BR		
11	790050	3	GASKET, VAC HE CVR		
12	790388	2	ASSEMBLY, HEATER CORE		
13	790755	1	HSG, VAC HE		
14	57111	2	MIT. 3/8-16 HEX		
15	620023	2	PLT, HEATER CORE CVR, STL		
16	790341	1	VAC MUFFLER		
17	36238	6	GROM, 1/2IDX1-1/4OD 1/8G 5/16W		
18	790343	3	PAD, BTM VAC HTR CORE		
19	790423	3	PAD, REAR VAC HTR CORE		
20	790814	1	TUBE, EXHAUST ZEEMS		
21	780800	2	GSKT, EXH, A-15 ZEEMS		
22	70266	6	SCR, 3/8-16 X 1" HHCS GR5 PLTD		
23	790039	1	GASKET, VAC HE BOX TO MUFFLER		
24	790051	6	PLT, NUT-VAC HE HSG		
25	790038	3	FORGING, HEATER CORE MANIFOLD		
26	42-902415	1	GSKT, EXH, NIS 20691-72W00		
27	11-800224	5	PLG, 3/8 SOCHD BR		
28	12-800225	1	ELL, ST 3/8 P X 1/2T BR		
29	00-000064	12	RIV, 1/8 x 3/8 ALUM		
30	620024	1	PLT, HEATER CORE CVR FRONT, STL		
31	50-502023	1	FLG, EXH NISSAN A-15		
32	790505	1	ASSEMBLY, HEATER CORE (COPPER)		INCLUDES 17 & 30
33	790775	1	CONV, CAT, ZEEMS		
34	87163	10	WASHER, 3/8 SPLIT LOCK PLTD		
35	01-000296	3	NUT, EXH MNFLD, A-15		
36	790891	1	O2 SENSOR		
37	87083	3	WASHER, 5/16 SPLIT LOCK, PLTD		

# SOLUTION TEMPERATURE CONTROL VALVE

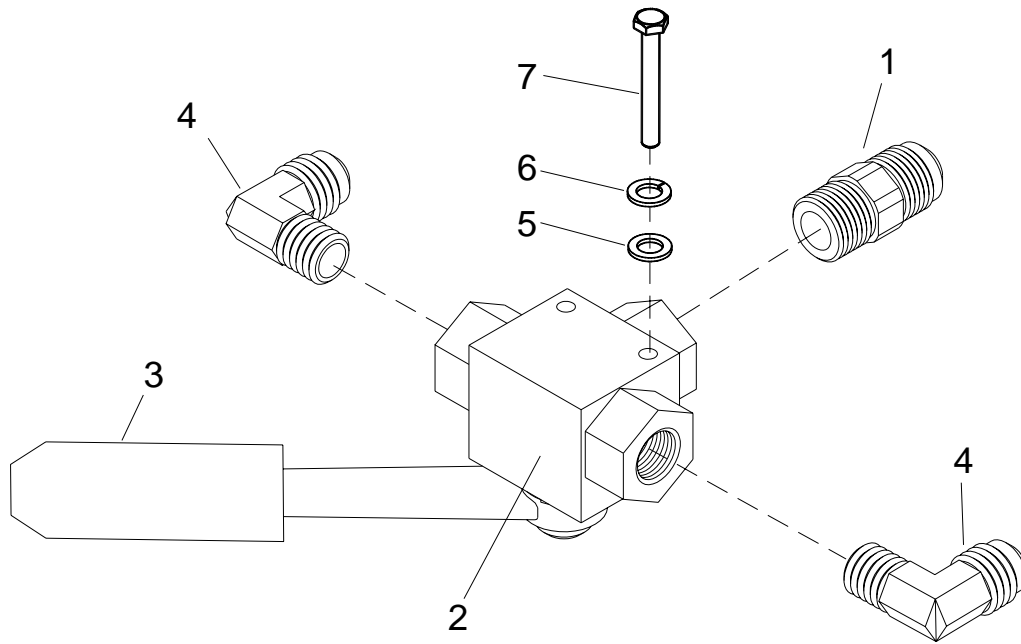

## **SOLUTION TEMPERATURE CONTROL VALVE**

REF	PART NO.	QTY	DESCRIPTION	SERIAL NO. FROM	NOTES:
1	12-800282	1	CONN, 3/89 X 1/2T BR		
2	84192	1	VLV, BALL, 3-WAY, HI-TEMP/PRES		INCLUDES REF 3
3	38317	1	HNDL, VALVE, 3-WAY, HI P/T		
4	12-800225	2	ELL, 3/8P X 1/2T BR		
5	02-000066	2	FLATWASHER, 1/4		
6	87162	2	WASHER, 1/4 SPLIT LOCK		
7	70017	2	SCR, CAP 1/4-20 X 2.50 HHCS		

# HELL-COIL HEAT EXCHANGER

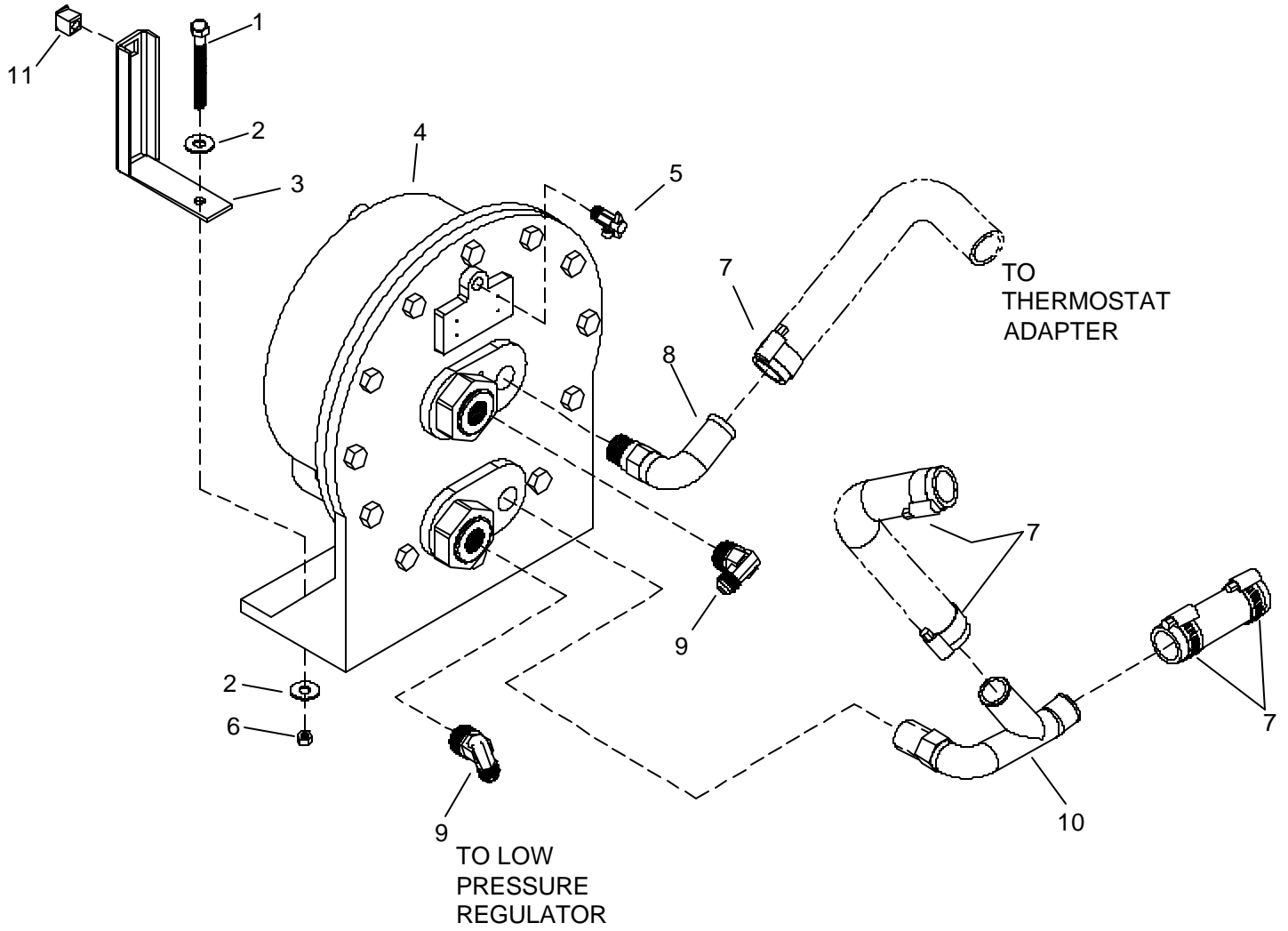

## HELI-COIL HEAT EXCHANGER

REF	PART NO.	QTY	DESCRIPTION	SERIAL NO. FROM	NOTES:
1	70554	2	SCR, 3/8-16 X 3.5 HHCS GR5PLTD		
2	87171	4	WASHER, 3/8 FLAT		
3	790445	1	BRKT, RIGHT HOOD MTG		
4	57-520073	1	HE, HELI-COIL		
5	15-808073	1	COCK, DRN 1/4P X 1/4 HOSE ELL		
6	57119	2	NUT, 3/8-16 HEX NYLOCK		
7	03-000248	5	CLMP, HOSE #16 1-1/2 MIN 1-3/4		
8	52-501627	1	INL, HE		
9	12-800326	2	ELL, 3/4P X 1/2T BR		
10	790885	1	CASTING LWR RAD HOSE ZEEMS		
11	01-000259	1	RECPT, SNAPIN 1/4 TURNFA		



# SOLUTION OUTLET

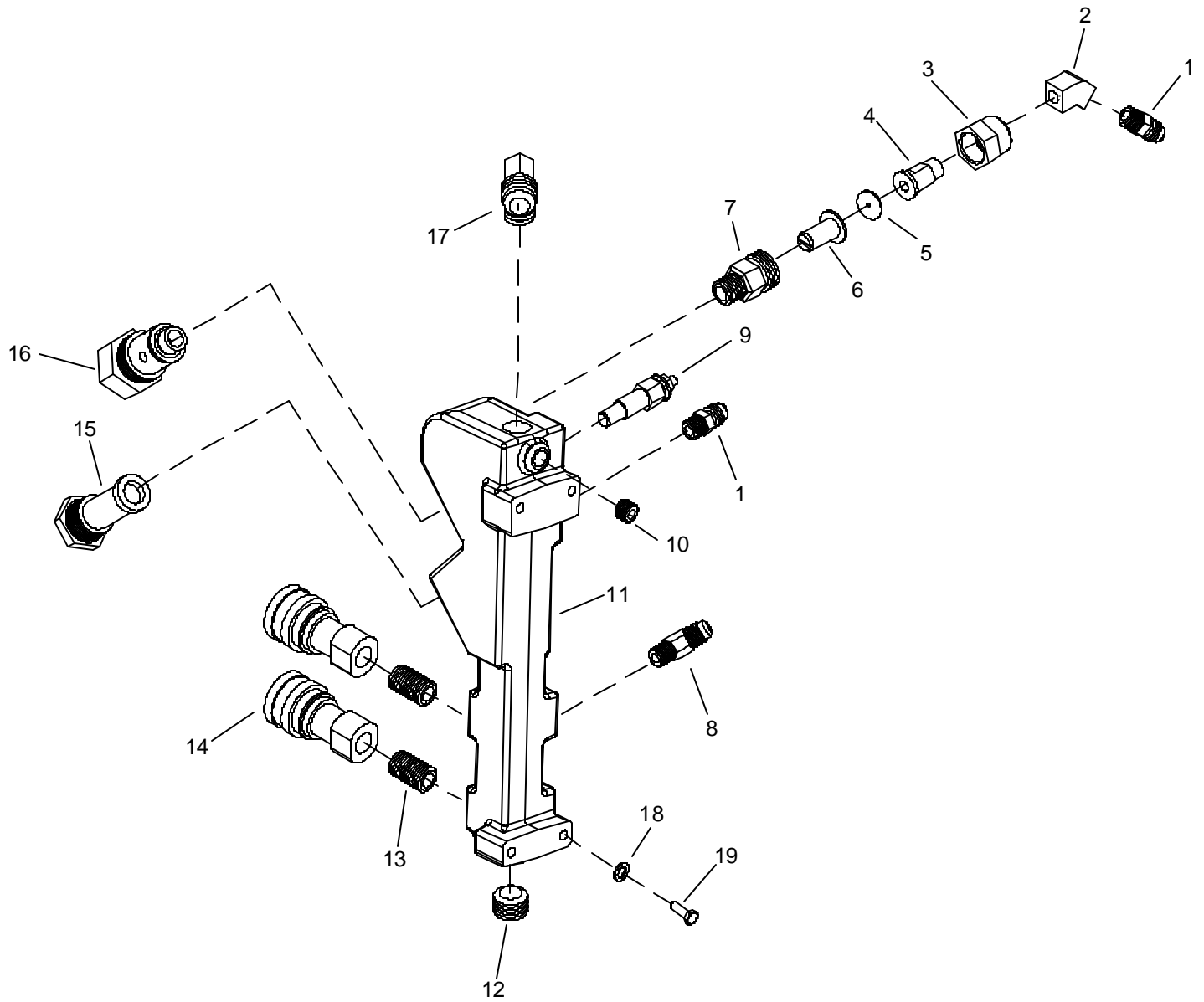

## SOLUTION OUTLET

REF	PART NO.	QTY	DESCRIPTION	SERIAL NO. FROM	NOTES:
1	12-800065	2	CONN, 1/8P X 1/4T		
2	31092	1	ELBOW, 1/8NPT 45D		
3	27074	1	CAP, NOZZLE		
4	790839	1	ADAPTER, HOSE BYPASS		
5	790836	1	ORFICE PLATE, EVEREST BYPASS		
6	14-806512	1	STRNR, JET 50 MESH		
7	17-803010	1	CONN, 1/4P X 11/16-16M		
8	12-800261	1	ELL, 1/8P X 1/4T 45 DEG		
9	34-903019	1	SENDER, TEMP 140-320DEG		
10	11-800206	1	PLUG, 1/8 SOCHD BR		
11	790844	1	MANIFOLD, SOLUTION		
12	11-800224	1	PLUG, 3/8 SOCHD BR		
13	56015	2	NIPPLE, 1/4 HEX		
14	22015	2	COUPLER, 1/4 QD		
15	730224	1	SCRN, MESH W/O-RING, SOL MNFLD		
16	15-808094	1	VALVE, CHECK		
17	12-800225	1	ELL, 3/8P X 1/2 T BR		
18	87162	2	WASHER, 1/4 SPLIT LOCK PLTD		
19	70270	2	SCR, 1/4-20 X 3/4 HHCS PLTD		

# WATER BOX-PP

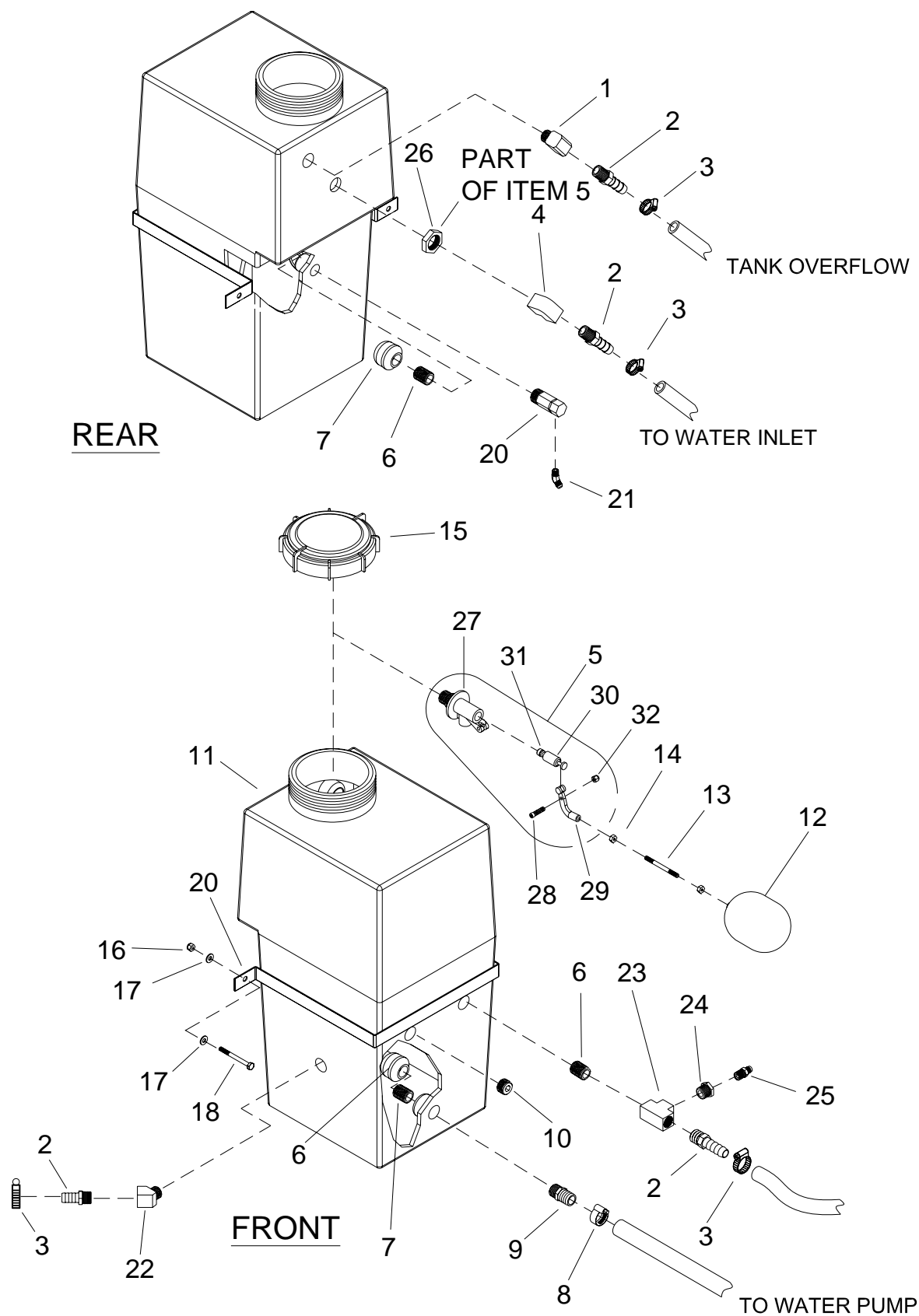

## WATER BOX-PP

REF	PART NO.	QTY	DESCRIPTION	SERIAL NO. FROM	NOTES:
1	31098	1	ELL, STREET 1/2 BR		
2	12-800269	2	FTTG, BRB 1/2P X 5/8H BR		
3	03-000246	7	CLAMP, HOSE #8 SST		
4	11-800361	1	ELL, 1/2 BR		
5	15-808110	1	VALVE, FLOAT		
6	11-800300	3	NIP, 1/2 X CL		
7	14-806540	2	STRAINER, SUC END 1/2FP		
8	03-000113	2	CLAMP, HOSE #12 SST		
9	12-800278	1	FTTG, BRB 1/2P X 3/4H BR		
10	11-800069	1	PLUG, 1/2 SOCHD BR		
11	790132	1	MLDG, WATER BOX		
12	19-807014	1	BALL, FLOAT		
13	790411	1	ROD, FLOAT (1/4-20 X 4") SS		
14	57006	1	NUT, 1/2-20 HEX		
15	11-800432	1	CAP, WATER BOX		
16	57047	2	NUT, 1/4-20 HEX NYLOCK		
17	02-000066	4	FLATWASHER, 1/4		
18	00-000286	2	SCR, CAP 1/4-20 X 2.75 HXHD		
19	790437	1	STRAP, WTR BOX HOLDDOWN		
20	15-808075	1	VLV, TEMP REL 145DEG		
21	12-800261	1	ELL, 1/8P X 1/4T 45 DEG		
22	11-800299	1	ELL, STREET 1/2 45 DEG		
23	11-800085	1	TEE, 1/2 BRASS		
24	11-800020	1	BUSH, 1/4 X 1/4 BR		
25	12-800060	1	CONN, 1/4P X 1/4T BR		
26	52-501706	1	NUT, FLOAT VALVE		
27	16-808217	1	BODY, FLOAT LVL		
28	00-000337	1	SCR, 10-32 X 1" SOCHD SST		
29	16-808216	1	ARM, PIVOT-FH VLV		
30	16-808219	1	PISTON, FH VLV		
31	16-808164	1	SEAT, FLOAT VLV		
32	57090	1	NUT, 10-32 HEX NYLOCK SS		

# WATER BOX-PPHP

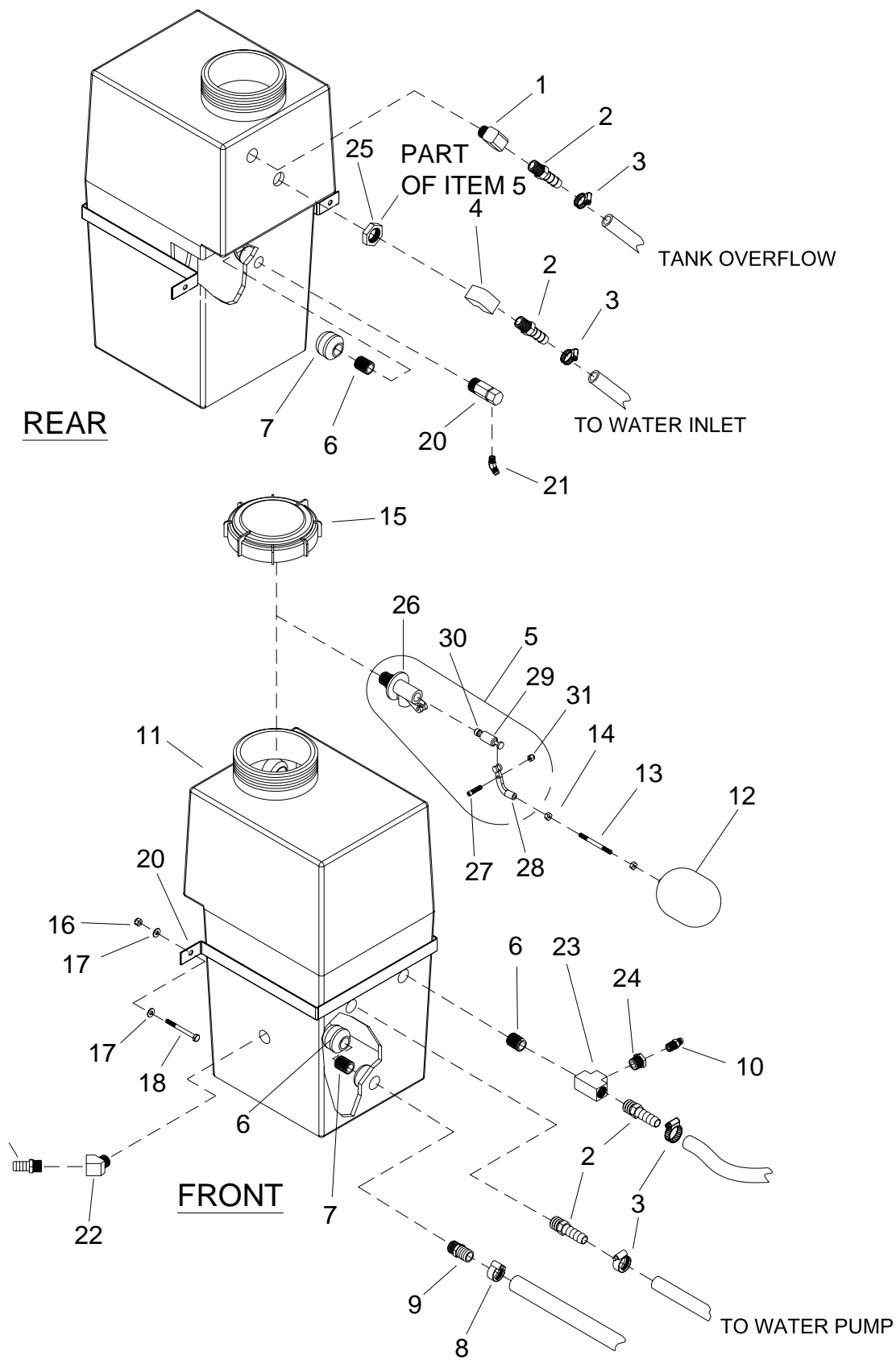

**WATER BOX-PPHP**

REF	PART NO.	QTY	DESCRIPTION	SERIAL NO. FROM	NOTES:
1	11-800041	1	ELL, STREET 1/2 BR		
2	12-800269	2	FTTG, BRB 1/2P X 5/8H BR		
3	03-000246	7	CLAMP, HOSE #8 SST		
4	11-800361	1	ELL, 1/2 BR		
5	15-808110	1	VALVE, FLOAT		
6	11-800300	3	NIP, 1/2 X CL		
7	14-806540	2	STRAINER, SUC END 1/2FP		
8	03-000113	2	CLAMP, HOSE #12 SST		
9	12-800278	1	FTTG, BRB 1/2P X 3/4H BR		
10	12-800060	1	CONN, 1/4P X 1/4T BR		
11	790132	1	MLDG, WATER BOX		
12	19-807014	1	BALL, FLOAT		
13	790411	1	ROD, FLOAT (1/4-20 X 4") SS		
14	57006	1	NUT, 1/2-20 HEX		
15	11-800432	1	CAP, WATER BOX		
16	57047	2	NUT, 1/4-20 HEX NYLOCK		
17	02-000066	4	FLATWASHER, 1/4		
18	00-000286	2	SCR, CAP 1/4-20 X 2.75 HXHD		
19	790437	1	STRAP, WTR BOX HOLDDOWN		
20	15-808075	1	VLV, TEMP REL 145DEG		
21	12-800261	1	ELL, 1/8P X 1/4T 45 DEG		
22	11-800299	1	ELL, STREET 1/2 45 DEG		
23	11-800085	1	TEE, 1/2 BRASS		
24	11-800020	1	BUSH, 1/4 X 1/4 BR		

# PRESSURE REGULATOR-PP

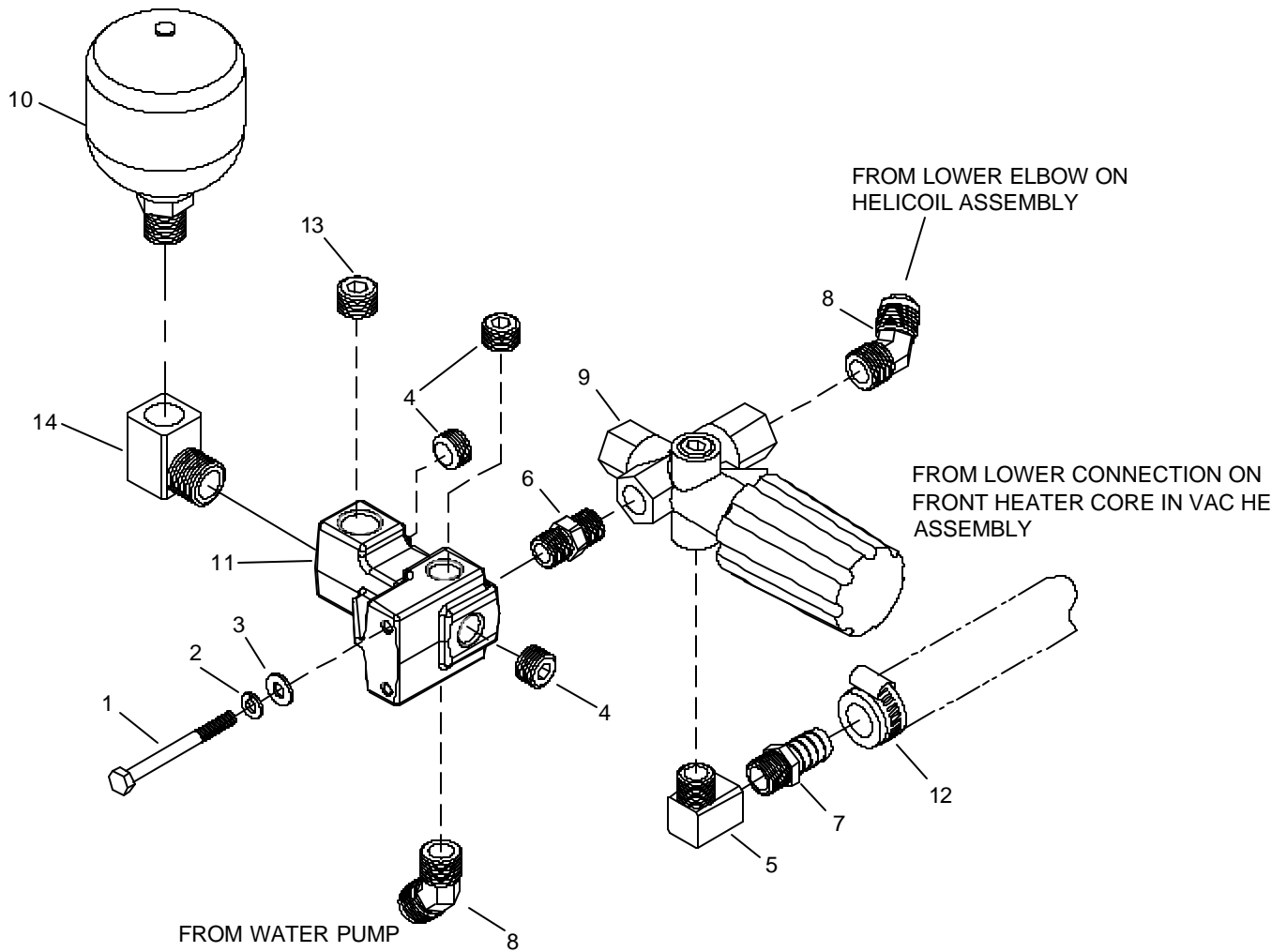

**PRESSURE REGULATOR-PP**

REF	PART NO.	QTY	DESCRIPTION	SERIAL NO. FROM	NOTES:
1	00-000286	2	SCR, CAP 1/4-20 X 2.75 HXHD		
2	87162	2	WASHER, 1/4 SPLIT LOCK		
3	02-000066	2	FLATWASHER, 1/4		
4	11-800224	2	PLUG, 3/8 SOCHD BR		
5	11-800275	1	ELL, ST 3/8 BR		
6	11-800429	1	NIP, HEX 3/8 SSTS		
7	12-800345	1	FTTG, BRB 3/8P X 5/8 H BR		
8	12-800347	2	ELL, 3/8P X 1/2T 45 DEG BR		
9	790067	1	REGULATOR , PRESSURE		
10	790106	1	ACCUMULATOR		
11	790901	1	MANIFOLD, PRESSURE		
12	03-000246	1	CLAMP, HOSE #8 SST		
13	11-800069	1	PLUG, 1/2 SOCHD BR		
14	31098	1	ELL, STREET 1/2 BR		



# PRESSURE REGULATOR-PPHP

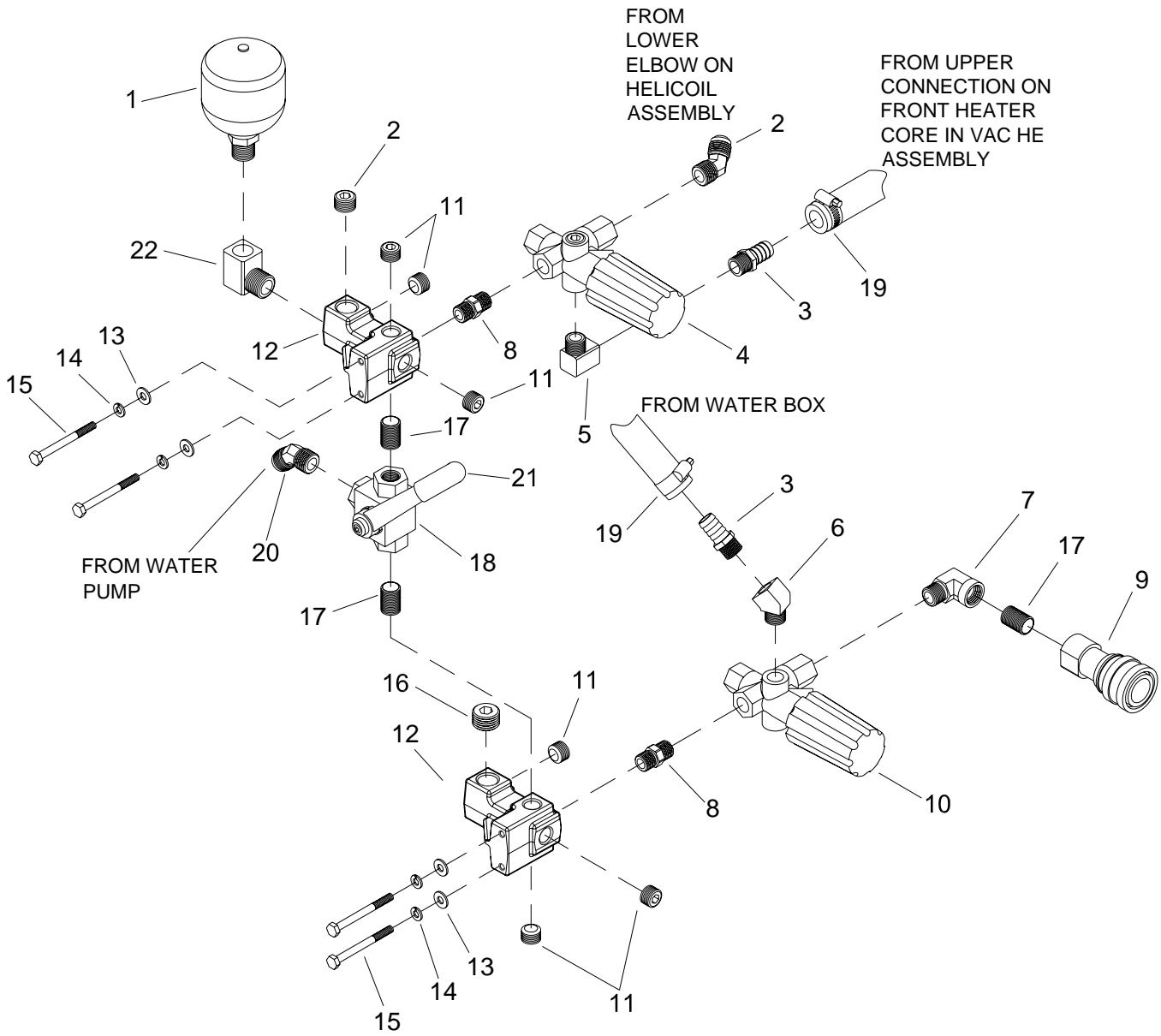

## PRESSURE REGULATOR-PPHP

REF	PART NO.	QTY	DESCRIPTION	SERIAL NO. FROM	NOTES:
1	790106	1	ACCUMULATOR, 250PSI CAT 6026		
2	12-800347	1	ELL, 3/8P X 1/2T 45 EG. BR		
3	12-800345	2	FTTG, BRB 3/8P X 5/8H BR		
4	790067	1	REG, PRESS CAT #7670AWI		
5	11-800275	1	ELL, ST 3/8 BR		
6	11-800341	1	ELL, ST 3/8 45 DEG BR		
7	11-800240	1	ELL, ST 3/8 SST		
8	11-800429	2	NIP, HEX 3/8 SST		
9	13-806040	1	DSC, 3/8F X 3/8FP SST		
10	15-808147	1	REG, PRESS CAT #7672 7 GPM		
11	11-800224	6	PLG, 3/8 SOCHD BR		
12	790901	2	MNFLD, PRESS		
13	02-000066	4	FLATWASHER, 1/4		
14	87162	4	WASHER, 1/4 SPLIT LOCK		
15	00-000286	4	SCR, CAP 3/4-16 X 6 HXHD		
16	11-800069	2	PLUG, 1/2 SOCHD BR		
17	11-800368	3	NIP, 3/8 X CL SST		
18	84192	1	VALVE, BALL, 3-WAY, HIPRESS/HI TEMP		INCLUDES ITEM 21
19	03-000246	4	CLAMP, HOSE #8 SST		
20	790478	1	ELBOW, 3/8P X 1/2T 45DEG SS		
21	38317	1	HNDL, VALVE, 3-WAY, HI P/T		
22	11-800041	1	ELL, STREET 1/2 BR		

# WASTE TANK

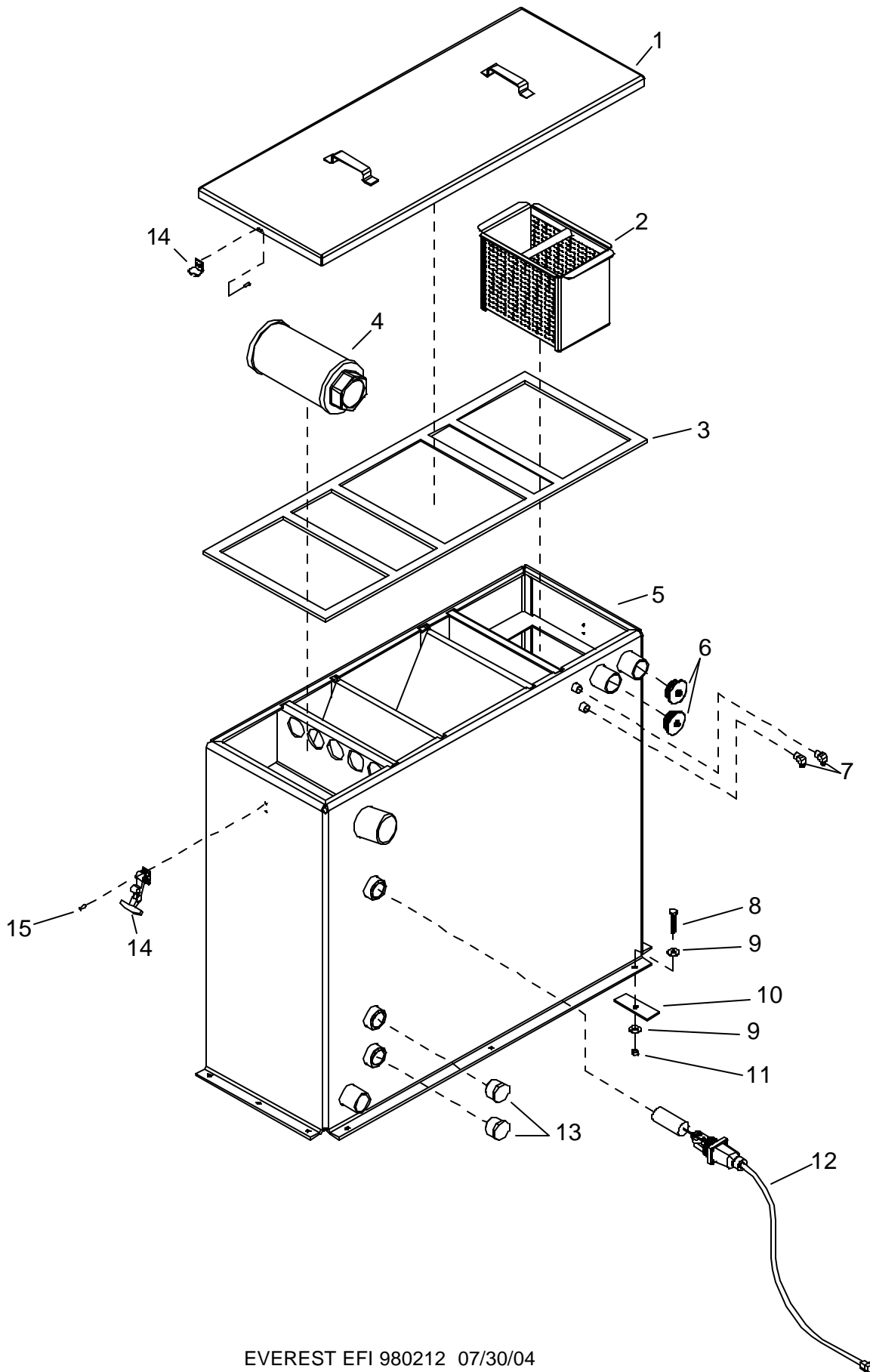

## WASTE TANK

REF	PART NO.	QTY	DESCRIPTION	SERIAL NO. FROM	NOTES:
1	790652	1	LID, 60G WST TNK		
2	56-501793	1	STRAINER BOWL		
3	790620	1	GSKT, PEAK WASTE TANK		
4	14-806518	1	STRAINER, WST TANK 2-1/2"		
5	05235	1	TNK, WST 60G CTK		
6	05236	2	ASM, VAC CVR, CTK		
7	12-800031	2	ELL, 1/4P X 1/4T BR		
8	00-000072	12	SCR, 3/8-16 X 2" HXHD		
9	87171	24	WASHER, 3/8 FLAT		
10	62986	12	PLATE, TRUCKMOUNT SHIPPING		
11	57119	12	NUT, 3/8-16 HEX NYLOCK		
12	791066	1	SWITCH, FLOAT, N.C. HARWIL		
13	11-800402	2	PLUG, 1-1/4 HXHD PVC		
14	46-802510	2	LATCH, DRAW 2-7/8 SST		
15	67006	4	RIVET, 3/16 OD X 5/8 AL		

# HOSE ACCESSORIES

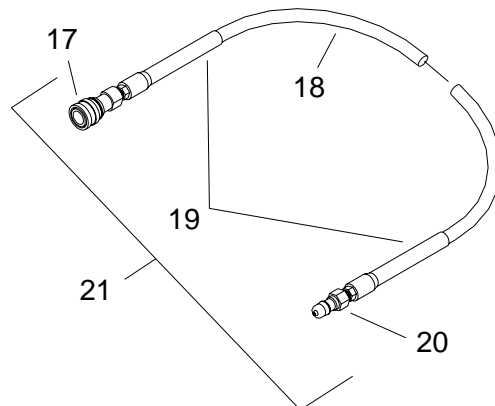
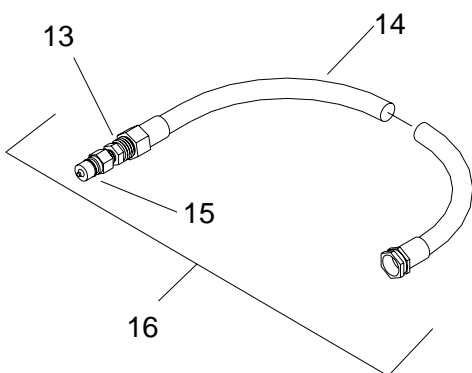
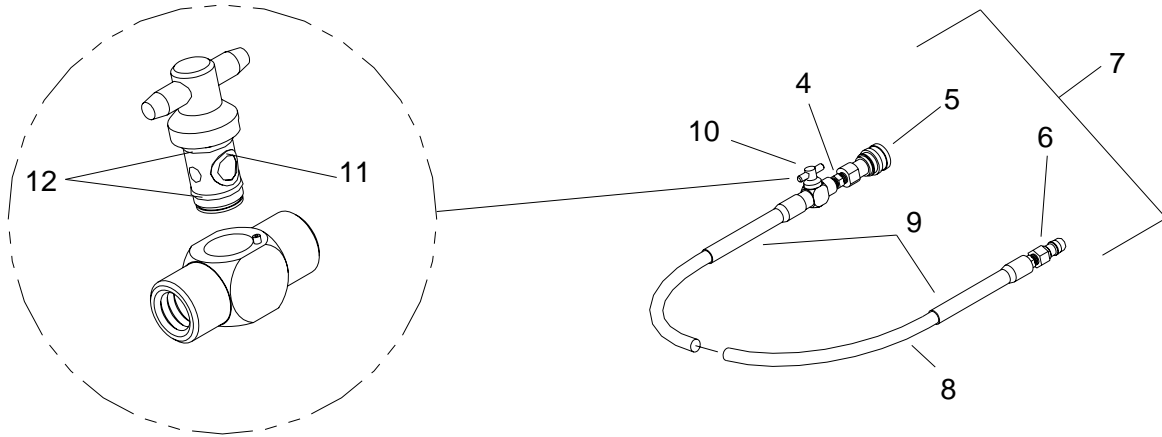
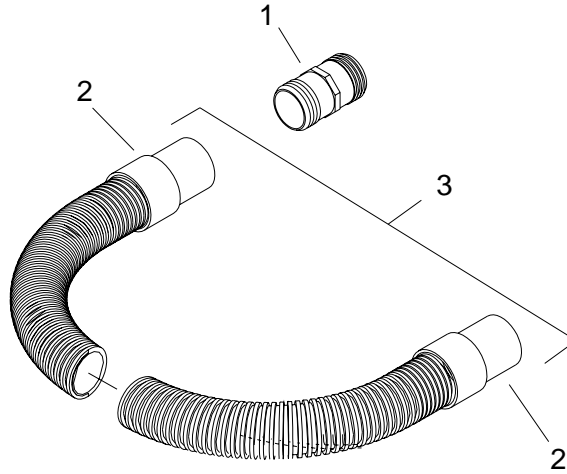

## HOSE ACCESSORIES

REF	PART NO.	QTY	DESCRIPTION	SERIAL NO. FROM	NOTES:
1	12-800078	1	FITTING, BRB 2H BS PVC		
2	08-805147	2	CUFF, 2"		
3	10-805060	1	HOSE, VAC 2"X50' W/ CUFFS & HOSE		
4	56015	1	NIPPLE, 1/4 HEX		
5	22015	1	COUPLER, 1/4 QD		
6	56012	1	NIPPLE, 1/4 FPT QD		
7	10-805108	1	HOSE, HP 1/4 X 50FT W/QD & VLVE		
8	10-805077	1	HOSE, HP 1/4 X 50'		
9	08-805155	2	GUARD, HOSE VINYL		
10	15-808012	1	VALVE, BALL 1/4FP		
11	43-810014	2	O-RING, 7/32ID X 11/32OD		
12	43-810019	2	O-RING, 3/8 ID X 1/2 OD		
13	11-800354	1	NIP, 1/2 X 3/8 HEX BR		
14	10-805157	1	HOSE, WATER 1/2 X 50'		
15	13-806009	1	DISCONNECT 3/8M X 3/8FP		
16	10-805295	1	HOSE, WATER 1/2 X 50'		
17	22015	1	COUPLER, 1/4 QD		
18	10-805077	1	HOSE, HP 1/4 X 50'		
19	08-805155	2	GUARD, HOSE VINYL		
20	56012	1	NIPPLE, 1/4 FPT QD		
21	10-805122	1	HOSE, HP 1/4 X 50FT W/QD		

# BATTERY-FLOOR MOUNT

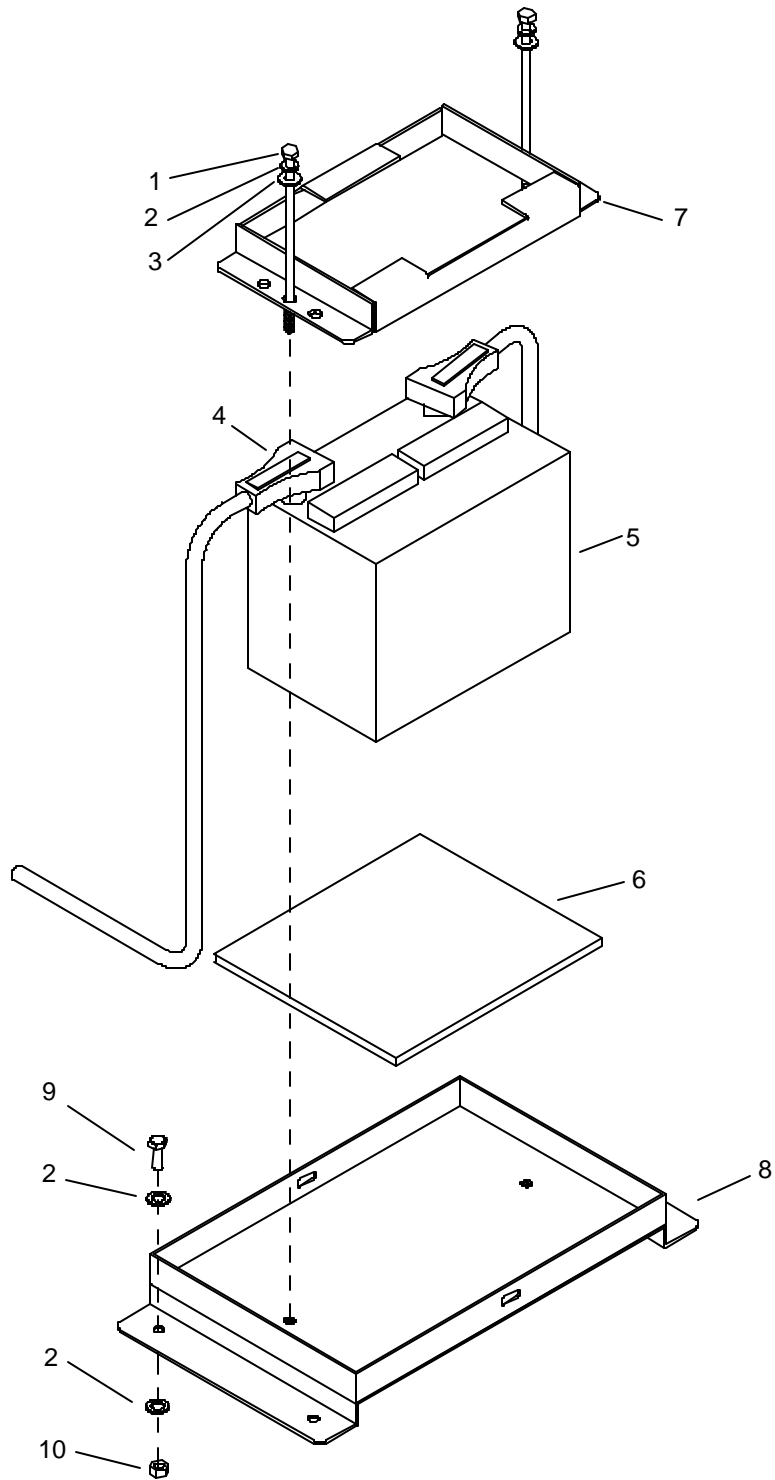

**BATTERY-FLOOR MOUNT**

REF	PART NO.	QTY	DESCRIPTION	SERIAL NO. FROM	NOTES:
1	00-000167	2	SCR, 1/4-20 X 6" HXHD		
2	87162	2	WASHER, 1/4 SPLIT LOCK		
3	02-000066	10	FLATWASHER, 1/4		
4	31-900179	1	COVER, BATTERY TERMINAL		
5	36-900056	1	BATTERY		
6	47-700007	1	SHIELD, BAT MT HT		
7	56-500188	1	COVER, BATTERY		
8	56-502049	1	TRAY, BAT FLOOR MT		
9	00-000132	4	SCR, 1/4-20 X 1-1/2 HXHD		
10	57006	4	NUT, 1/4-20 HEX		



# AUTOMATIC PUMPOUT-OPTIONAL

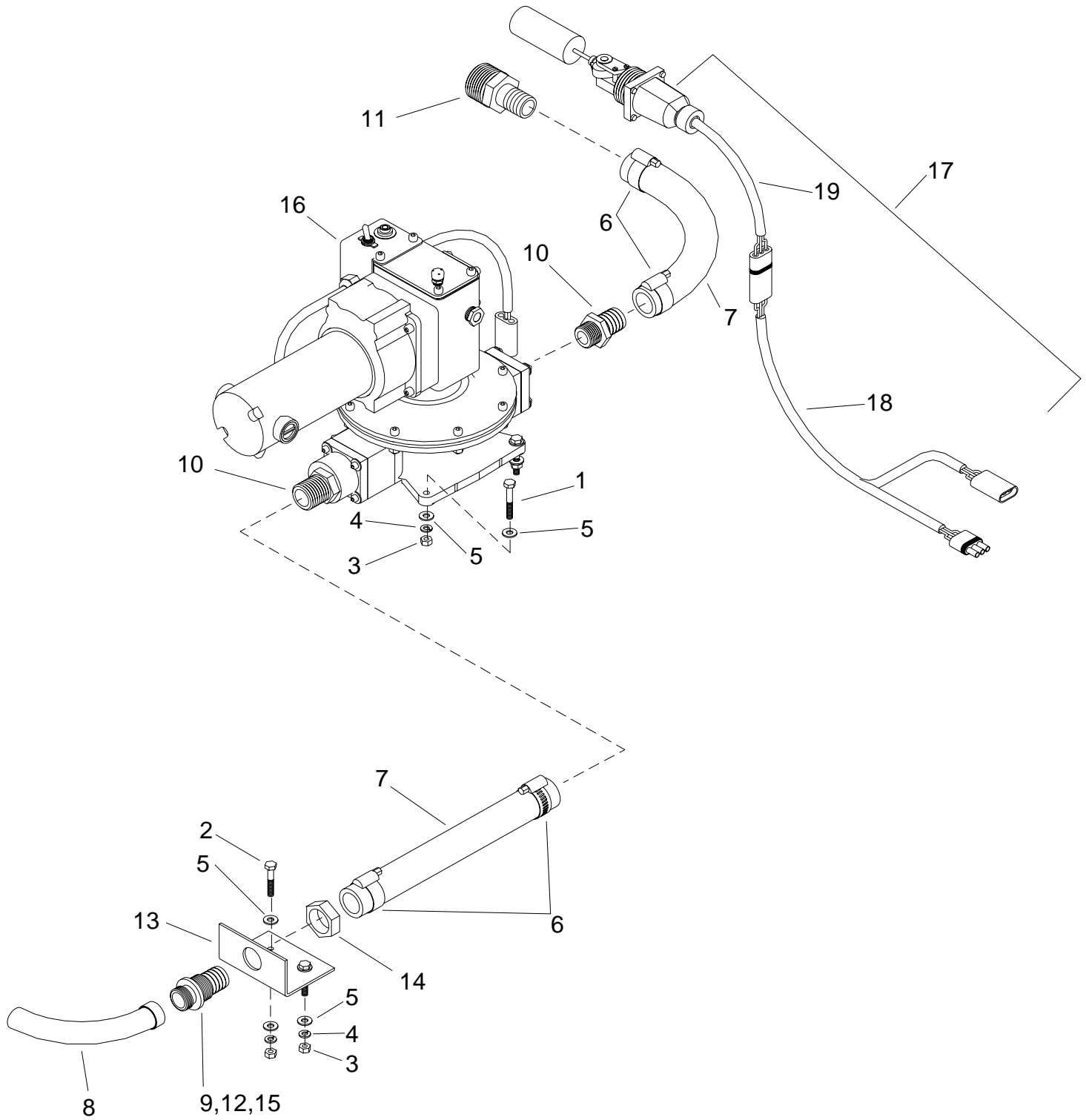

## AUTOMATIC PUMPOUT-OPTIONAL

REF	PART NO.	QTY	DESCRIPTION	SERIAL NO. FROM	NOTES:
1	70105	4	SCR, M4 X 60 PH		
2	00-000132	2	SCR, 1/4-20 X 1/ 1/2 HXHD		
3	57006	4	NUT, 1/4-20 HEX		
4	87162	4	WASHER, 1/4 SPLIT LOCK PLTD		
5	02-000066	4	FLATWASHER, 1/4		
6	03-000176	4	CLAMP, HOSE #16		
7	09-805591	1	HOSE, WASTE PUMP 1" X 8'		
8	10-805484	1	HOSE, GARDEN 3/4 X 75'		
9	12-800052	1	CAP, HOSE 3/4 BR		
10	12-800367	1	FTTG, BRB 1PX1H BR		
11	12-800444	1	FTTG, 1-1/4P X 1" H BR		
12	43-807008	1	WASHER, HOSE 5/8 ID 1" OD		
13	50-502055	1	BRKT, CTR HOOD FR		
14	52-000123	1	NUT, 1-3/16-12 UN HXHD		
15	52-501993	1	CONN, HOSE WATER OUTL		
16	61-951306	1	PUMP, HD AUTO		
17	61-951319	1	ASSY, LVL SENS SHUT OFF SW		
18	23719	1	CORD ASM, CNCTN SIDE		
19	72185	1	SWITCH ASSEMBLY		

# AUTOMATIC PUMPOUT-OPTIONAL

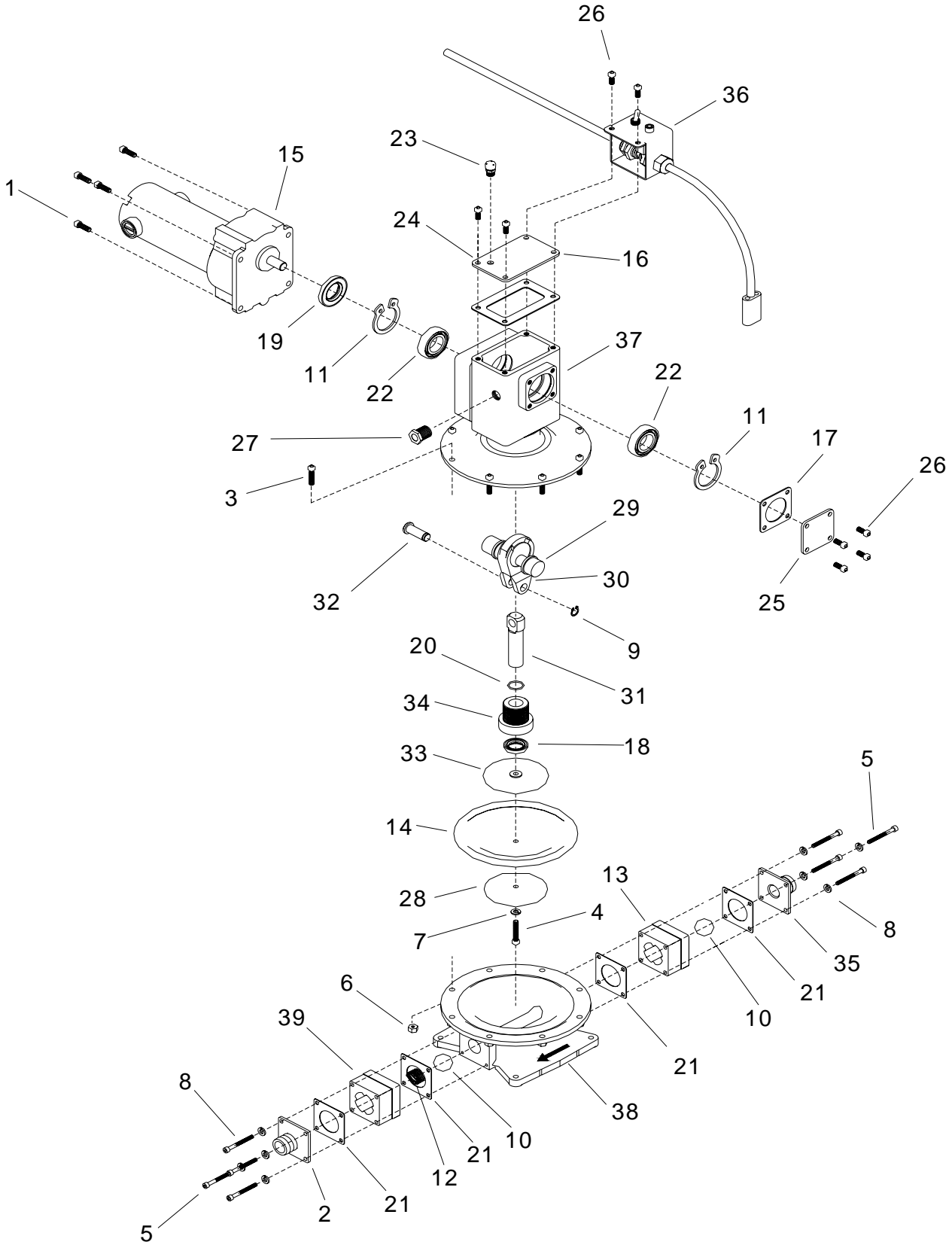

## AUTOMATIC PUMPOUT-OPTIONAL

REF	PART NO.	QTY	DESCRIPTION	SERIAL NO. FROM	NOTES:
1	00-000210	4	SCR, 1/4-20 X 3/4 SOCHD		
2	52-502064	1	CVR, OUTLET WST PMP-OUT		
3	00-000312	8	SCR, CAP 1/4 X 1 SOCHD		
4	00-000399	1	SCR, CAP 1/4 X 1 3/8 SOC		
5	00-000241	8	SCR, CAP 10-32 X 2 SOCHD SS		
6	57245	8	NUT, 1/4-20 HEX NYLOCK SS		
7	87162	1	WASHER, 1/4 SPLIT LOCK		
8	87165	8	WASHER, #10 SPLIT LOCK		
9	04-000312	1	RING, RETAIN EXT 1/2		
10	04-000334	2	BALL, NYL ID		
11	04-000335	2	RING, SNAP 1-7/8D		
12	04-000342	1	SPRING, PUMP-OUT BALL PRESS		
13	52-502061	1	BDY, INLET WST PMP-OUT		
14	16-808241	1	DIAPH, WST TNK PMP-OUT		
15	40-902151	1	MOTOR, 1/8HP 12V		
16	43-807117	1	GSKT, CVR TOP PMPOUT		
17	43-807118	1	GSKT, CVR SD PMPOUT		
18	43-810091	1	SEAL, PUMPOUT SHFT		
19	43-810100	1	SEAL PUMPOUT CAM		
20	43-810101	1	O-RING, 800/1000 .072		
21	43-810106	4	O-RING, 1-13/16 ID X 2 OD HDWP		
22	45-801927	4	BRG, SHFT PUMP-OUT		
23	49-876301	1	VENT, UPR SHFT BRNG HSG		
24	50-502025	1	PL, CVR TOP PUMP-OUT		
25	50-502026	1	PL, CVR SD PUMP-OUT		
26	70094	8	SCR, 1/4-20 X 1/2 SHCS SS		
27	11-800504	1	GA, FLOW SIGHT 3/8 NPT		
28	52-501828	1	BTM, PLNGR WST TNK PMP-OUT		
29	52-501829	1	SHT, 3/4" STROKE WST TNK		
30	52-501914	1	RD, CONNECT WST PMP-OUT		PART OF 31
31	52-501915	1	GUIDE, PLNGR WST PUMP-OUT		INCL. 32, 18, 30
32	52-501921	1	PIN, WRIST PUMP-OUT		
33	52-501934	1	TOP, PLNGR PUMP-OUT		
34	52-501950	1	BUSH, THREADED		
35	52-502062	1	CVR, INLET WST PMP-OUT		
36	56-502428	1	BRKT, PMP-OUT SW/CCT BRKR		
37	52-501821	1	TOP, WST TNK PUMP-OUT		
38	52-501820	1	BASE, WST TANK PMP-OUT		
39	52-502063	1	BDY, INLET WST PMP-OUT		

# WAND- TITANIUM SIX JET-OPTIONAL

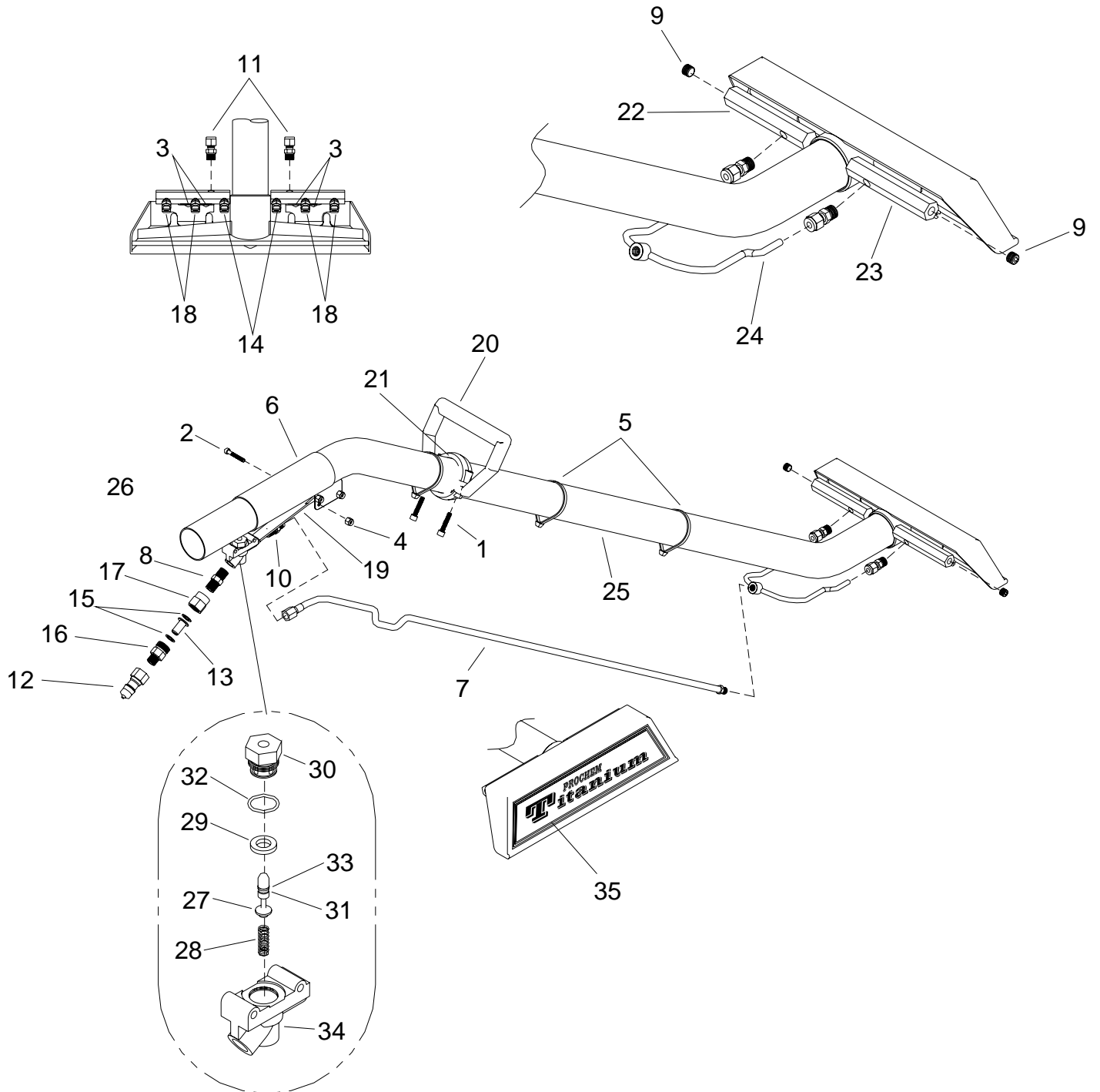

## WAND- TITANIUM SIX JET-OPTIONAL

REF	PART NO.	DESCRIPTION	SERIAL NO. FROM	NOTES:
1	00-000282	SCR, CAP 1/4-20 X 1 1/4 SOC		
2	00-000317	SCR, CAP 10-32 X 1 1/4 SOCH		
3	70228	SCR, 10-32 X 1/4 PPHMS SS		
4	57090	NUT, 10-32 HEX NYLOCK SS		
5	04-000093	TIE, CABLE 13"		
6	09-805603	HOSE, INT VAC 4-1/2 X 48		
7	10-805504	HOSE, 3/16 X 44-1/2		
8	56015	NIPPLE, 1/4 HEX		
9	11-800206	PLUG, 1/8 SOCHD BR		
10	12-800060	CONN, 1/4P X 1/4T BR		
11	12-800322	CONN, 1/8P X 1/4T COMP BR		
12	56012	NIPPLE, 1/4 FPT QD		
13	14-806512	STRAINER, JET 50 MESH		
14	17-803018	TIP, SPRAY 9501 X 1/8P SST		
15	17-803006	WASHER, NYLON		
16	17-803010	CONN, 1/4P X 11/16-16M		
17	17-803036	CONN, 1/4FP X 11/16-16F BR		
18	17-803078	TIP, SPRAY 8001 SST 1/8 VJET		
19	52-501619	TRIGGER, WD VALVE		
20	52-502008BK	BODY, WD HDL, 2" TB, BK		
21	52-502009	HOLD DN-WD HDL 2" TUBE		
22	52-502057	MANFOLD, LEFT		
23	52-502058	MANIFOLD, RIGHT		
24	56-502548	ASSY, MNFLD S-BEND		
25	56-502534	WD & HD TITANIUM		
26	61-950496	ASSY, EXTRACTOR VALVE		
27	16-808189	STEM, EXTRACTOR VALVE		
28	16-808190	SPRING, EXTRACTOR VALVE		
29	16-808228	SEAT, EXTRACTOR VALVE		
30	16-808229	HLDR, VLV STEM-EXTRACTOR VL		
31	43-810062	O-RING, .114 ID .254OD		
32	43-810063	O-RING, .551ID .691OD		
33	43-810064	BACK-UP, .250DIA		
34	52-501590	BDY, EXTRACTOR VLV		
35	48-941462	DEC, WD HD TITANIUM		
-	48-941296	BLB, INSPECTION QC (PINK)		

# WAND - QUAD-JET - OPTIONAL

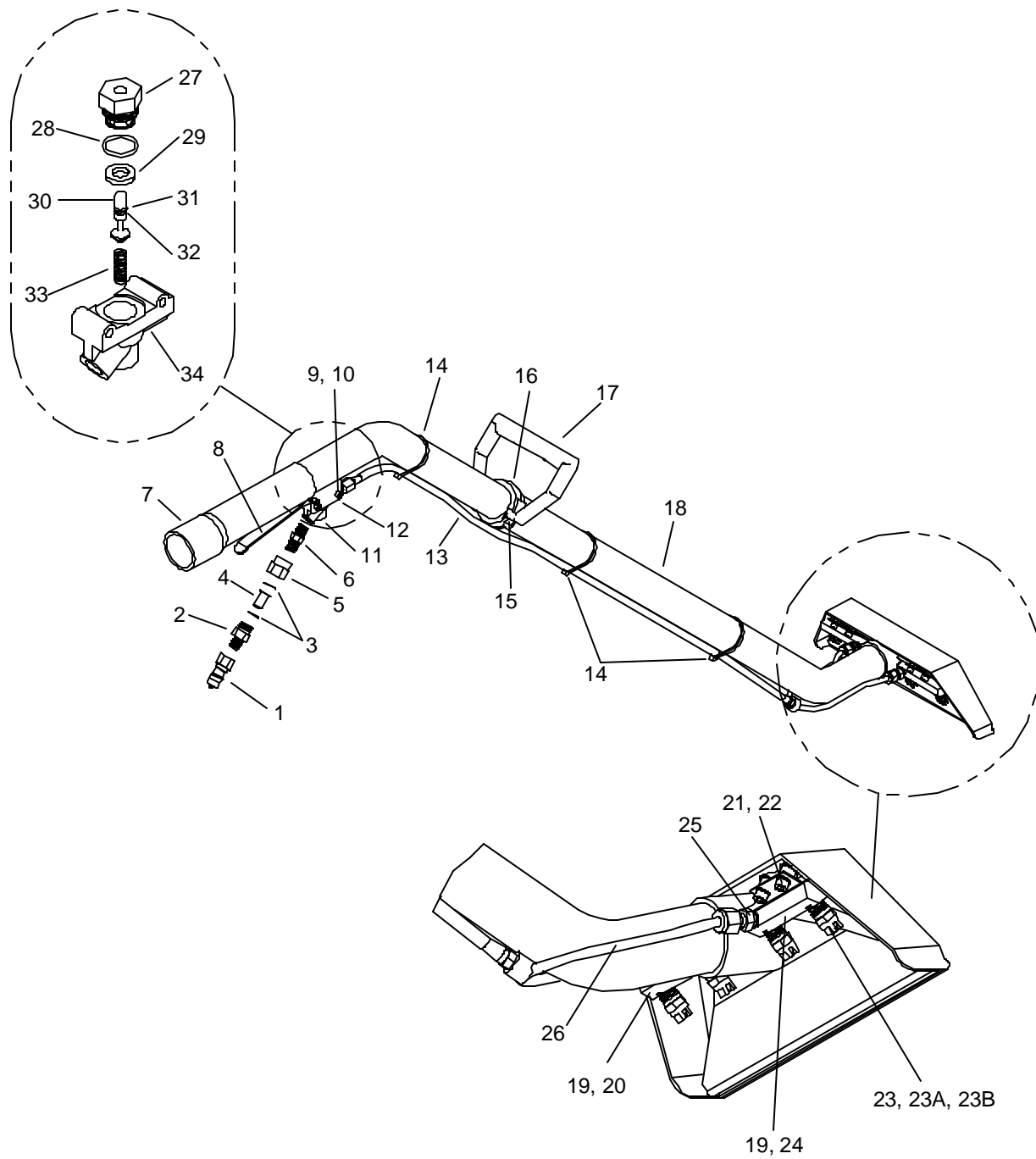

## WAND - QUAD-JET - OPTIONAL

REF	PART NO.	DESCRIPTION	SERIAL NO. FROM	NOTES:
-	89238	WAND, TM, QJW (95015) PC		COMPLETE
-	89239	WAND, TM, QJW (9502) PC		COMPLETE
-	89237	WAND, TM QJW (9501) PC		COMPLETE
-	89235	WAND, TM, QJW, (9501) NO DECAL		COMPLETE
1	56012	NIPPLE, 1/4 FPT QD		
2	17-503010	CONN, 1/4P X 11/16-16M		
3	17-803006	WASHER, NYLON		
4	14-806512	STRAINER, JET 50 MESH		
5	17-803036	CONN, 1/4FP,11/16-16R BR		
6	56015	NIPPLE, 1/4 HEX		
7	09-805359	SLEEVE, WD HDL 9.5		
8	52-501619	TRIGGER, WD VLV		
9	00-000317	SCR, CAP 10-32X 1-1/4 SOCH		
10	57090	NUT, 10-32 HEX NYLOCK SS		
11	61-950496	ASSY, EXTRCTR VLV		
12	12-800060	CONN, 1/4P X 1/4T BR		
13	10-805387	HOSE, 3/16 X 43-1/2 (1/8P X 1/4)		
14	04-000053	TIE, CABLE 8" WHT		
15	00-000282	SCR, CAP 1/4-20 X 1-1/4 SOC		
16	52-501569	HOLD DOWN, WD HDL		
17	52-501568	BODY, WD HDL		
18	56-501940	WAND & HEAD, CAST SST		
19	11-800206	PLUG, 1/8 SOCHD BR		
20	56-501966	ASSY, L S-BEND MNFLD		
21	00-000347	SCR, CAP 10-24 X1/4 SOCHD		
22	87165	WASHER, #10 SPLIT LOCK		
23	17-803001	TIP, SPRY 95015X1/8P SST		89238
23A	17-803002	TIP, SPRY 9502X1/8P SST		89239
23B	17-803018	TIP, SPRY 9501X1/8P SST		89237 89235 (NO DECAL)
24	56-501986	ASSY, RT S-BEND MNFLD		
25	12-800322	CONN, 1/8PX1/4T COMP BR		
26	56-501967	ASSY, S-BEND MNFLD		
27	16-808229	HOLDER, VLV STEM-EXTRCTR VL		
28	43-810063	O-RING, .551 ID .691 OD		
29	16-808228	SEAT, EXTRCTR VLV		
30	16-808189	STEM, EXTRCTR VLV		
31	43-810064	BACK-UP, .250 DIA		
32	43-810062	O-RING, .144 ID .254 OD		
33	16-808190	SPRING, EXTRCTR VLV		
34	52-501590	BODY, EXTRCTR VLV		
-	48-941186	DECAL, WD HD (CAST SS)		NOT SHOWN
-	66-808169	KIT, REP-WD VLV		NOT SHOWN INCLUDES PARTS 27-29 & 31-33



# WAND - TRI-JET - OPTIONAL

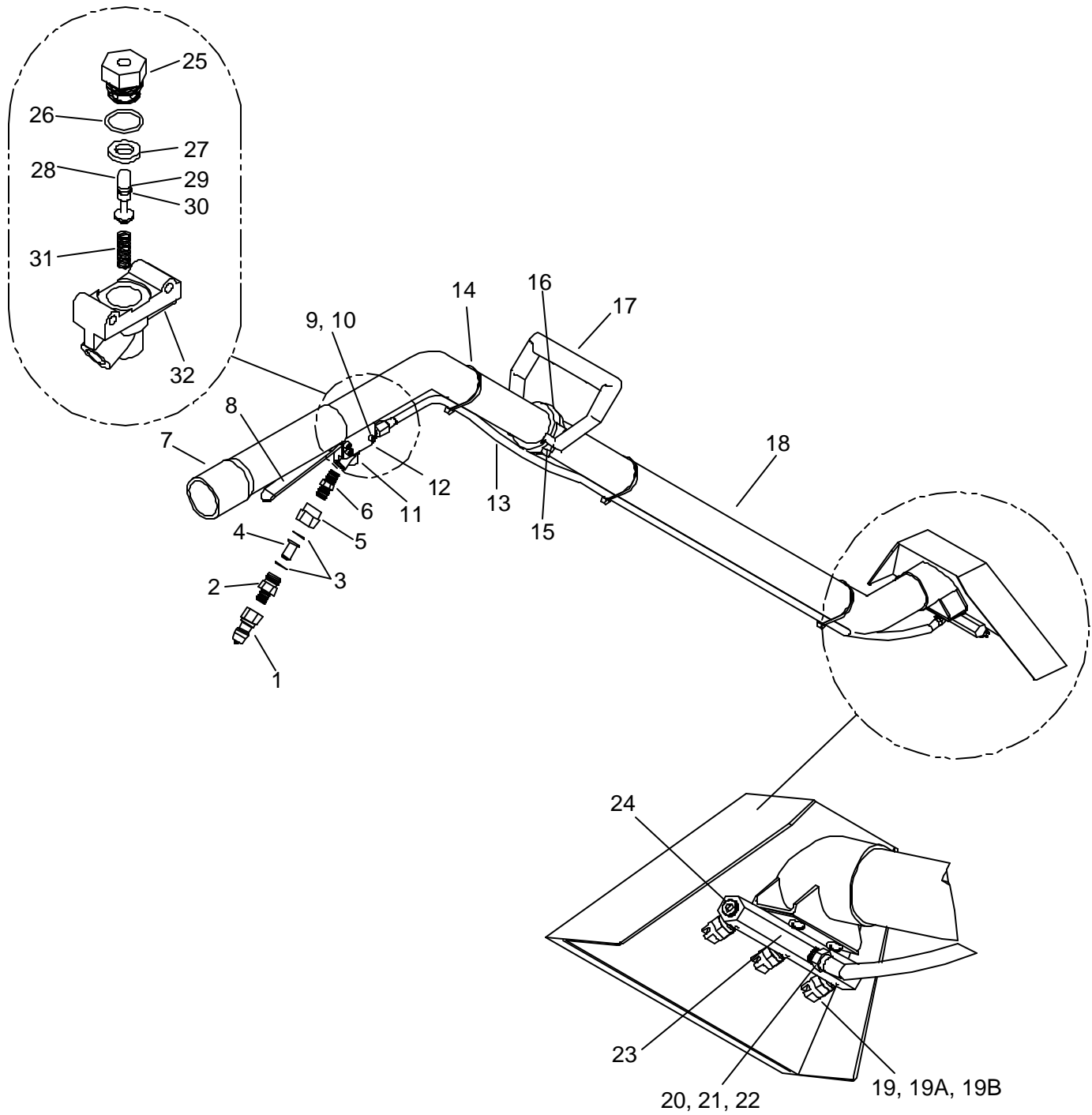

## WAND - TRI-JET - OPTIONAL

REF	PART NO.	DESCRIPTION	SERIAL NO. FROM	NOTES:
-	89233	WAND, TJW (9502) PC		COMPLETE
-	89232	WAND, TJW, (95015) CUBXL		COMPLETE
-	89234	WAND, TJW, (9503) PC		COMPLETE
1	56012	NIPPLE, 1/4 FPT QD		
2	17-503010	CONN, 1/4P X 11/16-16M		
3	17-803006	WASHER, NYLON		
4	14-806512	STRAINER, JET 50MESH		
5	17-803036	CONN, 1/4FP,11/16-16R BR		
6	56015	NIPPLE, 1/4 HEX		
7	09-805359	SLEEVE, WD HDL 9.5		
8	52-501619	TRIGGER, WD VLV		
9	00-000317	SCR, CAP 10-32X 1-1/4 SOCH		
10	57090	NUT, 10-32 HEX NYLOCK SS		
11	61-950496	ASSY, EXTRCTR VLV		
12	12-800060	CONN, 1/4P X 1/4T BR		
13	10-805253	HOSE, 3/16X49 (1/8P X 1/4FT)		
14	04-000053	TIE, CABLE 8" WHT		
15	00-000282	SCR, CAP 1/4-20 X 1-1/4 SOC		
16	52-501569	HOLD DOWN, WD HDL		
17	52-501568	BODY, WD HDL		
18	56-501712	WAND & HEAD, TRI-JET WD		
19	17-803002	TIP, SPRY 9502X1/8P SST		89233
19A	17-803001	TIP, SPRY 9501X1/8P SST		89232
19B	17-803046	TIP, SPRY 9503X1/8P SST		89234
20	70162	SCR, 10-32 X 3/8 PPHMS SS		
21	87165	WASHER, #10 SPLIT LOCK		
22	57014	NUT, 10-32 HEX SS		
23	56-501739	MANIFOLD, WD TRI-JET		
24	11-800206	PLUG, 1/8 SOCHD BR		
25	16-808229	HOLDER, VLV STEM-EXTRCTR VL		
26	43-810063	O-RING, .551 ID .691 OD		
27	16-808228	SEAT, EXTRCTR VLV		
28	16-808189	STEM, EXTRCT VLV		
29	43-810064	BACK-UP, .250DIA		
30	43-810062	O-RING, .114ID .254OD		
31	16-808190	SPRING, EXTRCTR VLV		
32	52-501590	BODY, EXTRCTR VLV		
-	48-941166	DECAL, WD HD		NOT SHOWN
-	66-808169	KIT, REP-WD VLV		NOT SHOWN INCLUDES PARTS 25-27 & 29-31

# STAIR TOOL-OPTIONAL

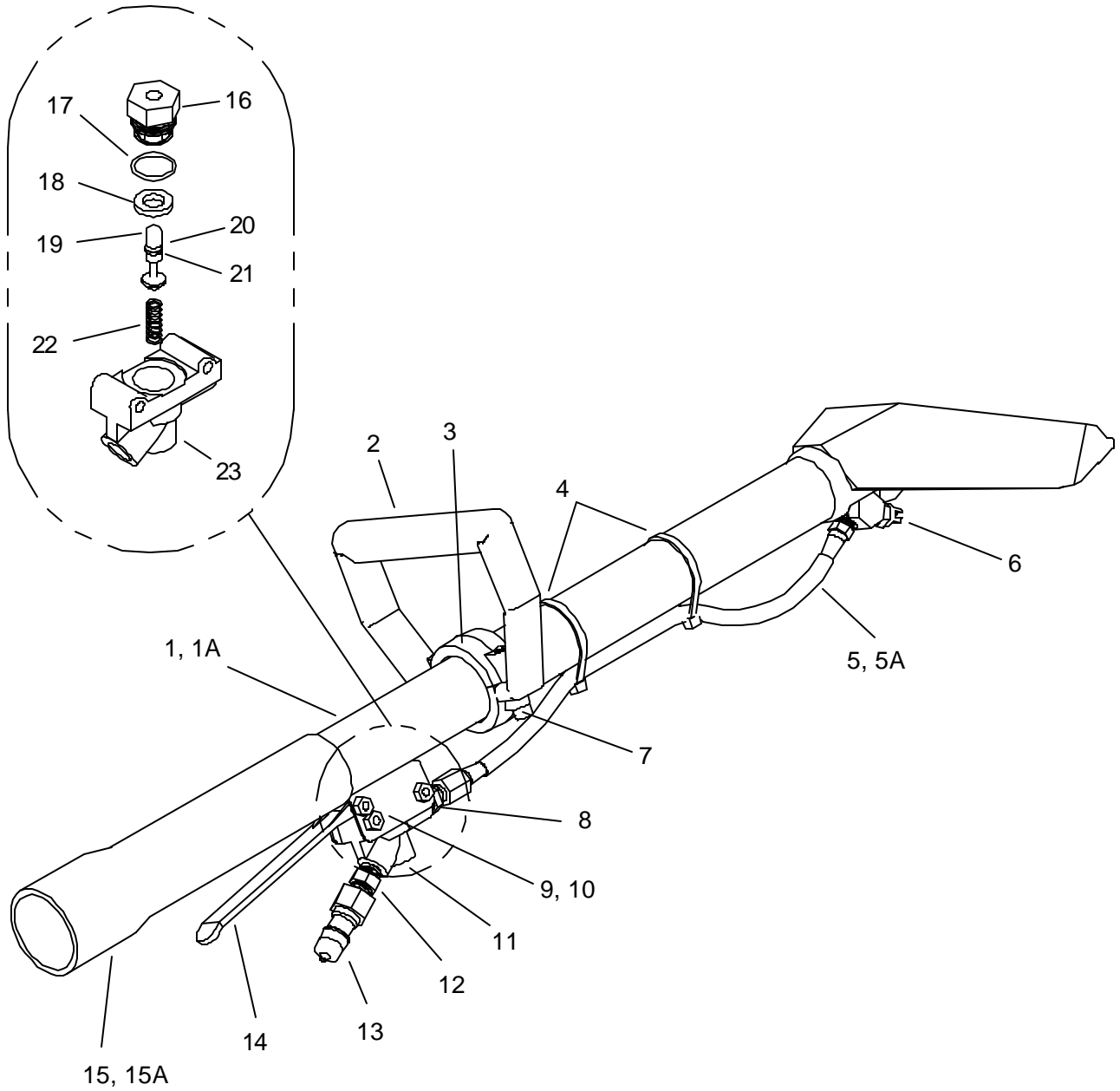

## STAIR TOOL-OPTIONAL

REF	PART NO.	DESCRIPTION	SERIAL NO. FROM	NOTES:
-	78519	TL, STAIR, LNG, TM DJ (80015)		COMPLETE
-	78521	TL, STAIR, SHT, TM (80015)		COMPLETE
1A	56-501715	WAND & HEAD, STAIR TL		
1B	56-501907	WAND & HEAD, SHRT STAIR TL		
2	52-501576	BODY, WD HDL PORT		
3	52-501577	HOLD DOWN, WD HDL PORT		
4	04-000053	TIE, CABLE 8" WHT		
5A	10-805330	HOSE, 3/16X13-3/4 (1/8PX1/4)		
5B	10-805397	HOSE, 3/16X7-1/2 (1/8P X 1/4F)		
6	17-803002	TIP, SPRY 9502X1/8P SST		
7	00-000282	SCR, CAP 1/4-20 X 1-1/4 SOC		
8	12-800060	CONN, 1/4P X 1/4T BR		
9	00-000317	SCR, CAP 10-32X1-1/4 SOCH		
10	57090	NUT, 10-32 HEX NYLOCK SS		
11	61-950496	ASSY, EXTRCTR VLV		
12	56015	NIPPLE, 1/4 HEX		
13	56012	NIPPLE, 1/4 FPT QD		
14	52-501619	TRIGGER, WD VLV		
15A	09-805359	SLEEVE, WD HDL 9.5		
15B	09-805504	SLEEVE, STAIR TL HDL 7-1/8		
16	16-808229	HOLDER, VLV STEM-EXTRCTR VL		
17	43-810063	O-RING, .551 ID .691 OD		
18	16-808228	SEAT, EXTRCTR VLV		
19	16-808189	STEM, EXTRCTR VLV		
20	43-810064	BACK-UP, .250DIA		
21	43-810062	O-RING, .114 ID .254 OD		
22	16-808190	SPRING, EXTRCTR VLV		
23	52-501590	BODY, EXTRCTR VLV		
-	48-941163	DECAL, STAIR TL		NOT SHOWN
-	66-808169	KIT, REP-WD VLV		NOT SHOWN INCLUDES PARTS 16-19 & 20-22

# UPHOLSTERY TOOL-OPTIONAL

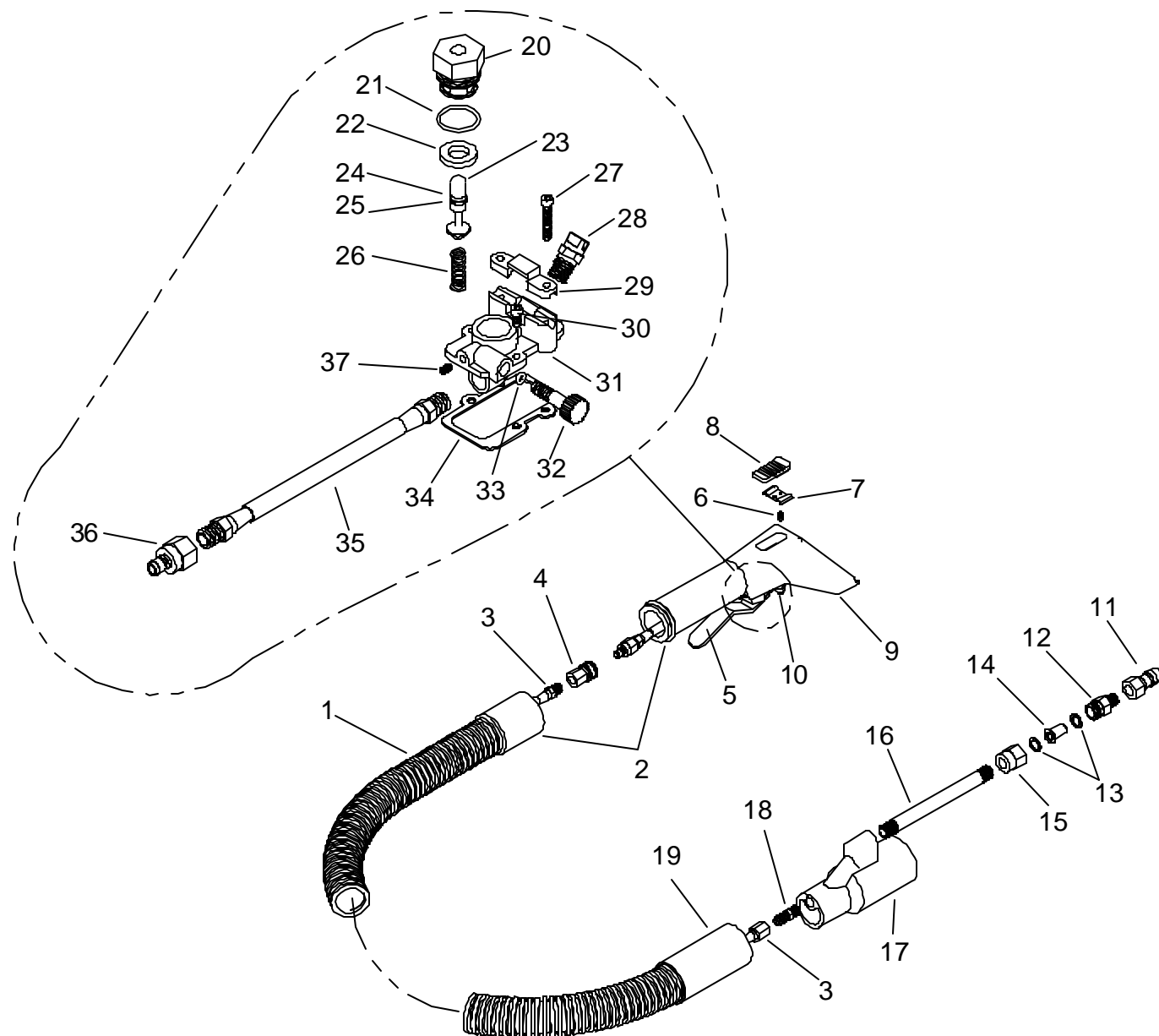

## UPHOLSTERY TOOL-OPTIONAL

REF	PART NO.	QTY	DESCRIPTION	SERIAL NO. FROM	NOTES:
-	78513	1	TL, UPHOLST, PC (80015)		COMPLETE
1	09-805131	2	HOSE, VAC 1-1/4X10' BLU		
2	08-805243	1	CUFF, SWIV 1-1/4HX1-1/4T		
3	10-805347	1	HOSE, 3/16X119-1/2 (1/8PX1/4FT)		
4	13-806023	1	DSC, 1/8FC1/8FP SST		
5	58-500639	1	UPHOLSTERY TL TRIGGER		
6	00-000310	1	SCR, CAP 4-40 X7/32 SHCS SS		
7	04-000282	1	SPRING, VAC ADJ BUTT		
8	52-501624	1	BUTTON, VAC ADJ		
9	52-501842	1	TOOL, UPHOLSTERY		
10	61-950570	1	ASSY, UPHLST TL VLV		INCLUDES PARTS 20-26, 28, & 31- 37
11	560012	1	NIPPLE, 1/4 NPT QD		
12	17-803010	1	CONN, 1/4P X 11/16-16M		
13	17-803006	1	WASHER, NYLON		
14	14-806512	1	STRAIRNER, JET 50MESH		
15	17-803036	1	CONN, 1/4FPX11/16-16F BR		
16	11-800404	1	NIP, 1/4X5 SST		
17	52-501585	1	COUPLER, UPHLST TL		
18	12-800065	1	CONN, 1/8P X 1/4T		
19	08-805138	1	CUFF, 1 1/4H X 1 1/2T GRY		
20	16-808229	1	HOLDER, VLV STEM-EXTRCTR VL		
21	43-810063	1	O-RING, .551 ID .691 OD		
22	16-808228	1	SEAT, EXTRCTR VLV		
23	16-808189	1	STEM, EXTRCTR VLV		
24	43-810064	1	BACK-UP, 250DIA		
25	43-810062	1	O-RING, .144 ID .254 OD		
26	16-808190	1	SPRING, EXTRCTR VLV		
27	00-000306	2	SCR, 6-32 X 1 SCHD SS		
28	17-803033	1	TIP, SPRY 80015X1/8P SST		
29	58-500638	1	CSTG, TRIGGER CLMP		
30	00-000307	2	SCR, CAP 6-32X3/8 SOCHD		
31	52-501623	1	VALVE, UPHLST TL		
32	52-501626	1	VALVE, ADJ-UPHLST TL VLV		
33	43-810016	1	O-RING, 5/32IDX9/32OD VIT		
34	43-807513	1	GASKET, UPHLST TL VLV		
35	10-805348	1	HOSE, 3/16X6-1/2 (1/8P BS)		
36	13-806030	1	DSC, 1/8MX1/8FP SST		
37	00-000408	1	SCR, SET 3-32 X 1/4 SOCHD		
-	48-941164	1	DECAL, UPHLST TL		NOT SHOWN
-	66-808169	1	KIT, REPAIR-WAND VLV		NOT SHOWN INCLUDES PARTS 20-22 & 24-26

# SHELF ASSEMBLY-OPTIONAL

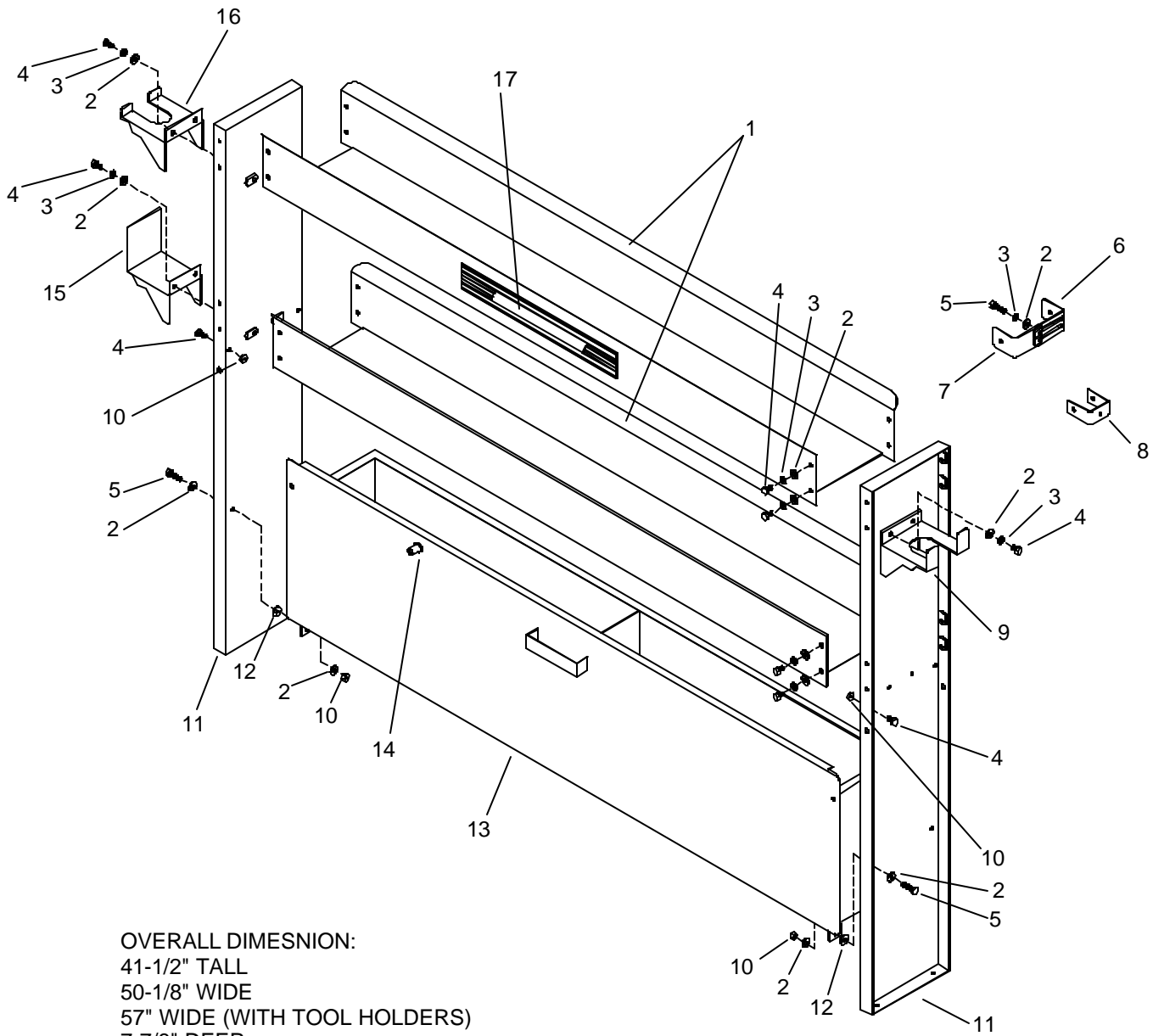

OVERALL DIMENSION:  
 41-1/2" TALL  
 50-1/8" WIDE  
 57" WIDE (WITH TOOL HOLDERS)  
 7-7/8" DEEP

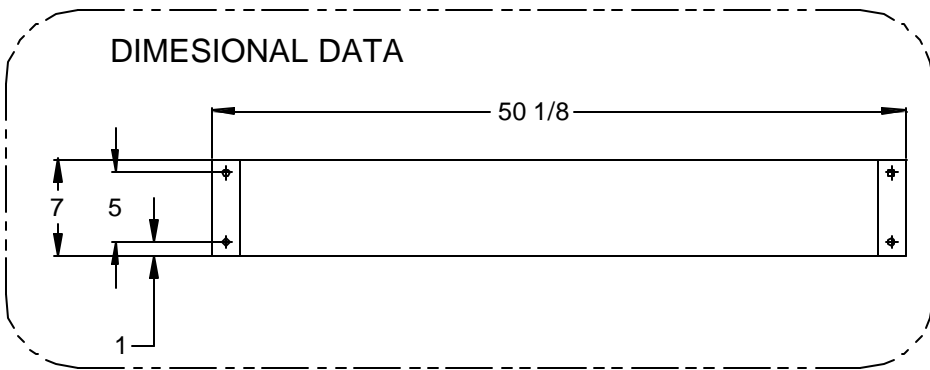

## SHELF ASSEMBLY-OPTIONAL

REF	PART NO.	QTY	DESCRIPTION	SERIAL NO. FROM	NOTES:
-	65-950392	1	VAN STORAGE UNIT		COMPLETE
1	56-501921	1	SHELF, LWR		
2	02-000066		FLATWASHER, 1/4		
3	87162		WASHER, 1/4 SPLIT LOCK		
4	70721		SHOULDER BOLT, 182 OD X 2.25 L		
5	70270		SCR, 1/4-20 X3/4 HHCS PLTD		
6	50-501840	1	BRKT, ADJUST MTG SLOT		
7	56-502067	1	BRKT, ADJUST MTF HLDR		
8	56-501942	1	BRKT, SHELF MOUNTING		
9	50-501753	1	HOLDER, STAIR TOOL		
10	01-000105		LOCK NUT, 1/4-20 HXHD		
11	56-501922	2	PANEL, SHLF END		
12	50-501749		WASHER, NYLON		
13	56-501920	1	DRAWER, SHELF GRAY		
14	46-802506	1	LATCH, ADJ GRIP		
15	50-501755	1	HOLDER, UP TO HOSE		
16	50-501754	1	HOLDER, UPHST TL		
17	48-941152	1	DECAL, PROCHEM		
-	66-945424	1	KIT, ADJ BRKT.		INCLUDES PARTS 6,7 & MOUNTING HARDWARE



# WATER TANK, DUAL WITH DEMAND PUMP-OPTIONAL

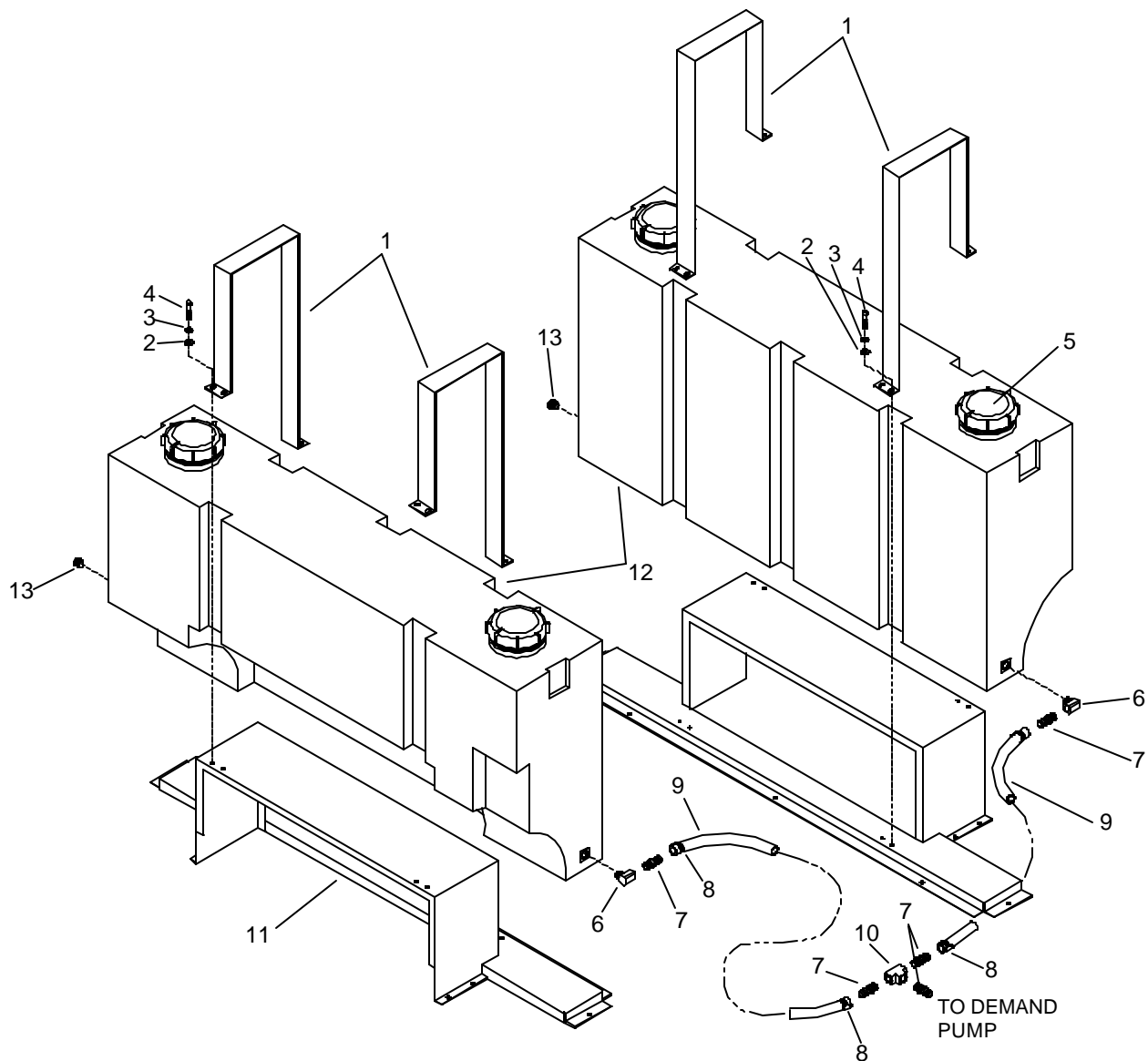

OVERALL DIMENSION:  
 32-1/2" TALL  
 62-5/8" WIDE  
 15-1/2" DEEP

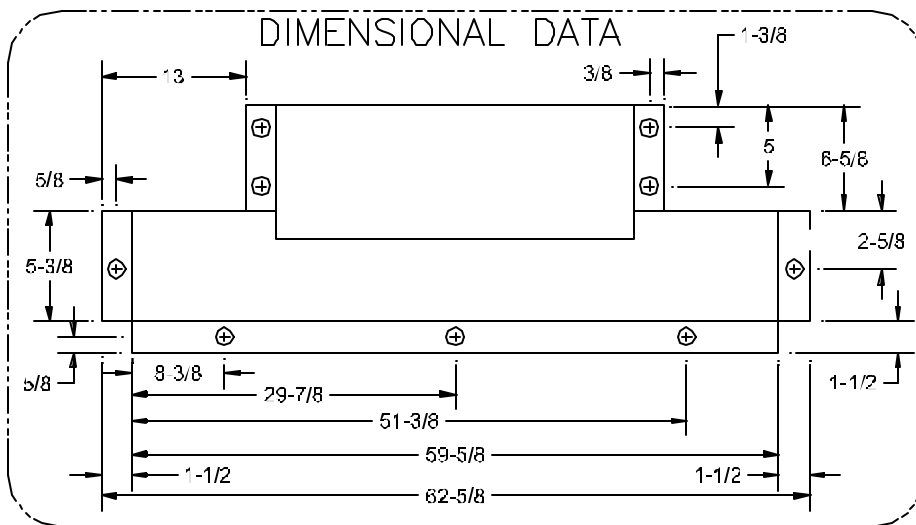
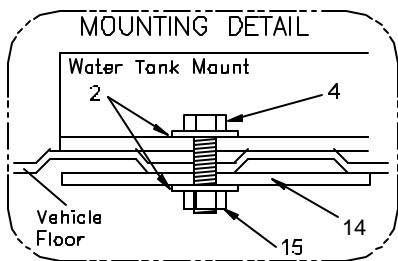

## **WATER TANK, DUAL WITH DEMAND PUMP-OPTIONAL**

REF	PART NO.	QTY	DESCRIPTION	SERIAL NO. FROM	NOTES:
-	66-945260	-	TANK, DUAL SADDLE W/DMD PUMP		COMPLETE
-	66-945265	-	SINGLE SADDLE TANK W/DMND PMP		COMPLETE
1	50-501774	4	HOLD DOWN, SADDLE TANK GRAY		
2	87171	16	WASHER, 3/8 FLAT		
3	87163	16	WASHER 3/8 SPLIT LOCK		
4	00-000072	16	SCR, 3/8-16 X 2' HXHD		
5	11-800432	4	CAP, WATER BOX		
6	11-800041	2	ELL, STREET 1/2 BR		
7	12-800278	4	FTTG, BRB 1/2P X 3/4H BR		
8	03-000113	4	CLAMP, HOSE #12 SST		
9	09-805456	1	HOSE, WTR 3/4 X 96"		
10	11-800085	1	TEE, 1/2 BRASS		
11	56-502000	2	ASSY, BASE SADDLE TANK GRAY		
12	58-500661	2	MOLDING, WATER TANK		
13	11-800168	2	PLUG, 1/2 BRASS HXHD		
14	50-500511	1	PLATE, INSTALL MT		
15	57119	9	NUT, 3/8-16 HEX NYLOCK		
-	41458	1	SHLR, CHEM, 10-GAL JUG		NOT SHOWN

# WATER TANK - DEMAND PUMP-OPTIONAL

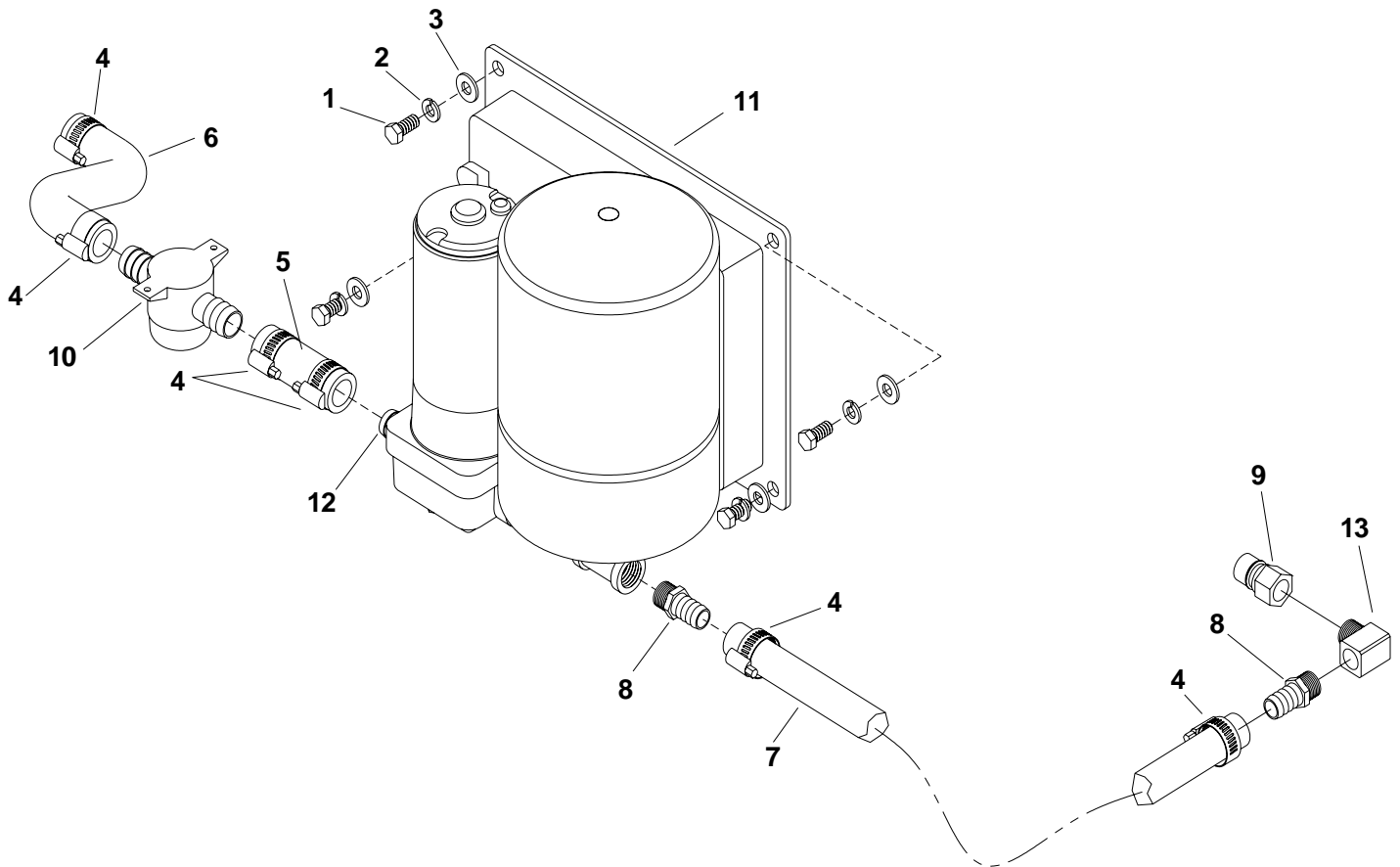

## WATER TANK - DEMAND PUMP-OPTIONAL

REF	PART NO.	QTY	DESCRIPTION	SERIAL NO. FROM	NOTES:
1	70305	4	SCR, 5/16-18 X 3/4 HHCS GR5 PL TDL		
2	87083	4	WASHER, 5/16 SPLIT LOCK PLTD		
3	02-000143	4	WASHER, 5/16 FLAT		
4	03-000113	6	CLAMP, HOSE #12 SST		
5	09-805278	1	HOSE, WATER 3/4 X 3"		
6	09-805357	1	HOSE, WATER .75 X 5.5		
7	09-805446	1	HOSE, WATER 5/8 X 55		
8	12-800345	1	FTTG, BRB 3/8P X 5/8H BR		
9	13-806009	1	DISCONNECT, 3/8M X 3/8FP		
10	14-806553	1	FILTER, DEMAND PUMP		
11	41-905049	1	PUMP, WATER BOOSTER FLOJET 2		
12	48-809423	1	KIT, PORT		
13	11-800275	1	ELBOW, ST 3/8 BR		
14	65240	1	PUMP ONLY, TM DEMAND		NOT SHOWN
15	47449	1	KIT SERVICE DEMAND PMP FJ		NOT SHOWN

# HOSE REEL-OPTIONAL

## DIMENSIONAL DATA

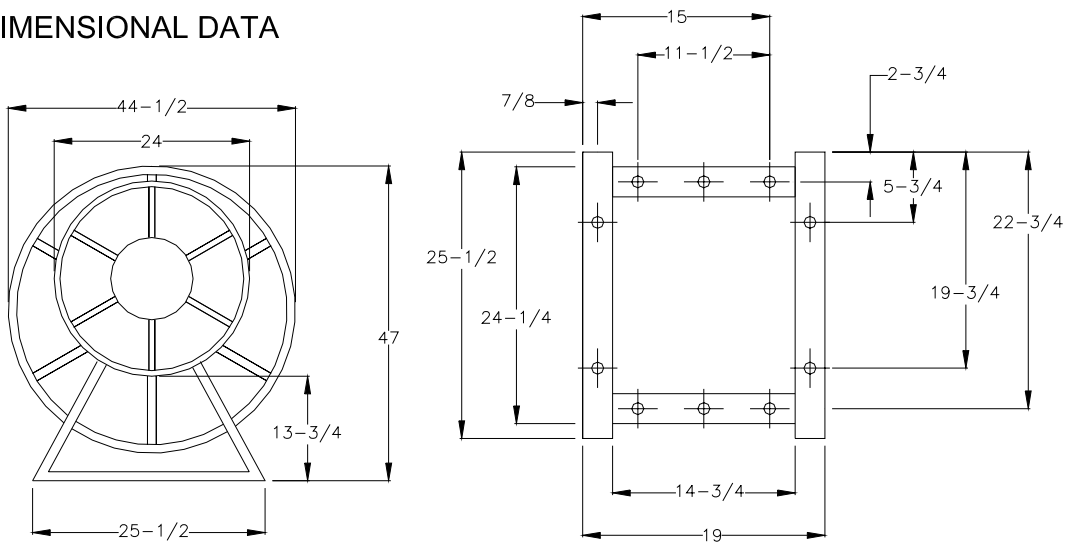

## MOUNTING DETAIL

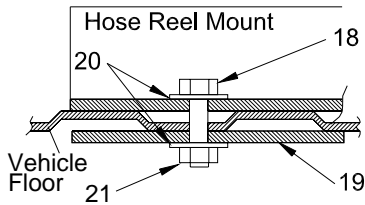

OVERALL DIMENSIONS: 47" TALL  
29" WIDE  
44-1/2" DEEP

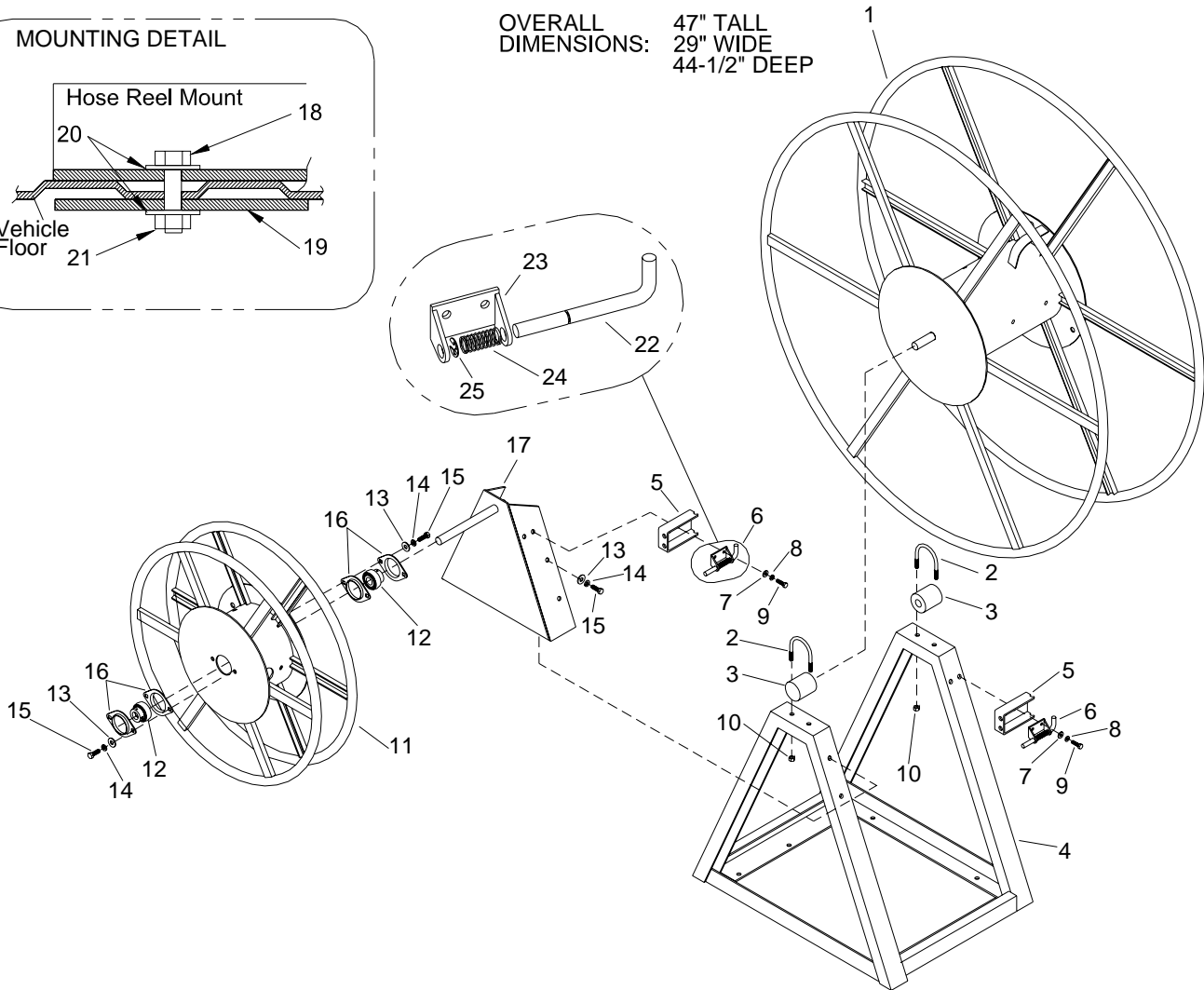

## HOSE REEL-OPTIONAL

REF	PART NO.	QTY	DESCRIPTION	SERIAL NO. FROM	NOTES:
1	56-501962	1	REEL, VACUUM HOSE GRAY		
2	03-000124	2	CLAMP, MFLR 1-3/4		
3	52-501685	2	BUSHING, HOSE REEL		
4	56-501960	1	BASE, HOSE RL (250')		
5	56-502207	1	BRKT, LOCKOUT HOSE REEL		
6	61-950854	1	LATCH ASSEMBLY		
7	02-000066	2	FLATWASHER, 1/4		
8	87162	2	WASHER, 1/4 SLPIT LOCK		
9	70270	2	SCR, 1/4-20 X 3/4 HHCS PLTD		
10	57031	2	NUT, 5/16-18 HEX		
11	56-501968	1	REEL, HP HOSE GRAY		
12	45-802138	2	BEARING HOSE REEL		
13	02-000143	4	FLATWASHER, 5/16		
14	87083	4	WASHER, 5/16 SPLIT LOCK PLTD		
15	70302	4	SCR, 5/16-18 X 1" HHCSGR5PLT		
16	44-802122	4	FLANGE, 47MST		
17	56-501961	1	BODY, HP HOSE GRAY		
18	00-000072	10	SCR, 3/8-16 X 2" HXHD		
19	50-500511	1	PLATE, INSTALL MT		
20	87171	10	WASHER, 3/8 FLAT		
21	57119	10	NUT, 3/8-16 HEX NYLOCK		
22	55-501789	1	PIN, LOCK HOSE REEL		
23	50-501812	1	BRKT, HOSE REEL LOCK		
24	04-000302	1	SPRING, LOCK-LOCK PIN ASSY		
25	04-000303	1	CLIP, RETAINER-LOCK PIN ASSY		

# WIRING SCHEMATIC

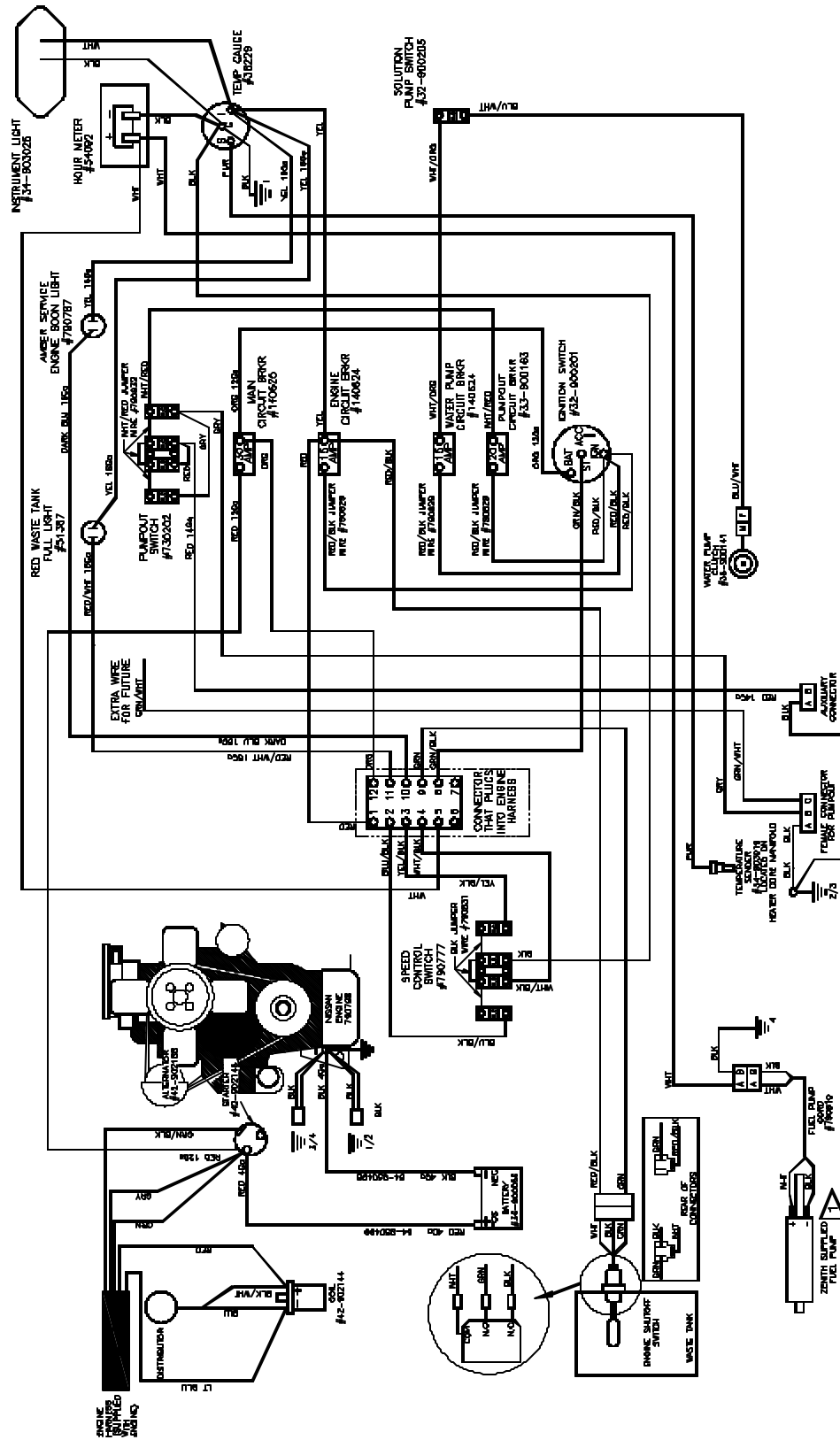

⚠ DO NOT GROUND FUEL PUMP TO MOUNTING BOX OR CHASSIS OF VAN. USE SUPPLIED FUEL PUMP CORD ONLY.

# HOSE DIAGRAM-PP

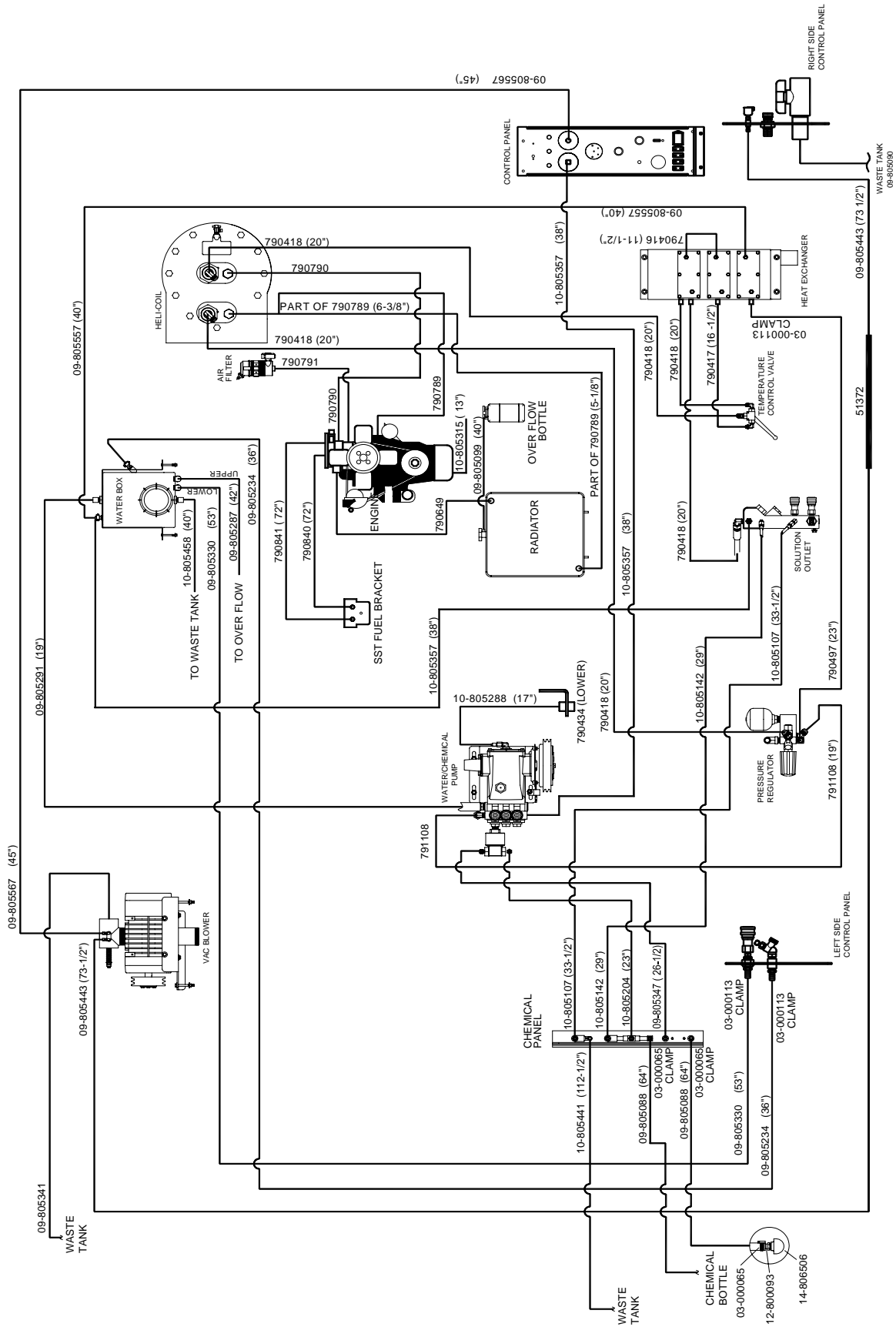



# HOSE DIAGRAM-PPHP

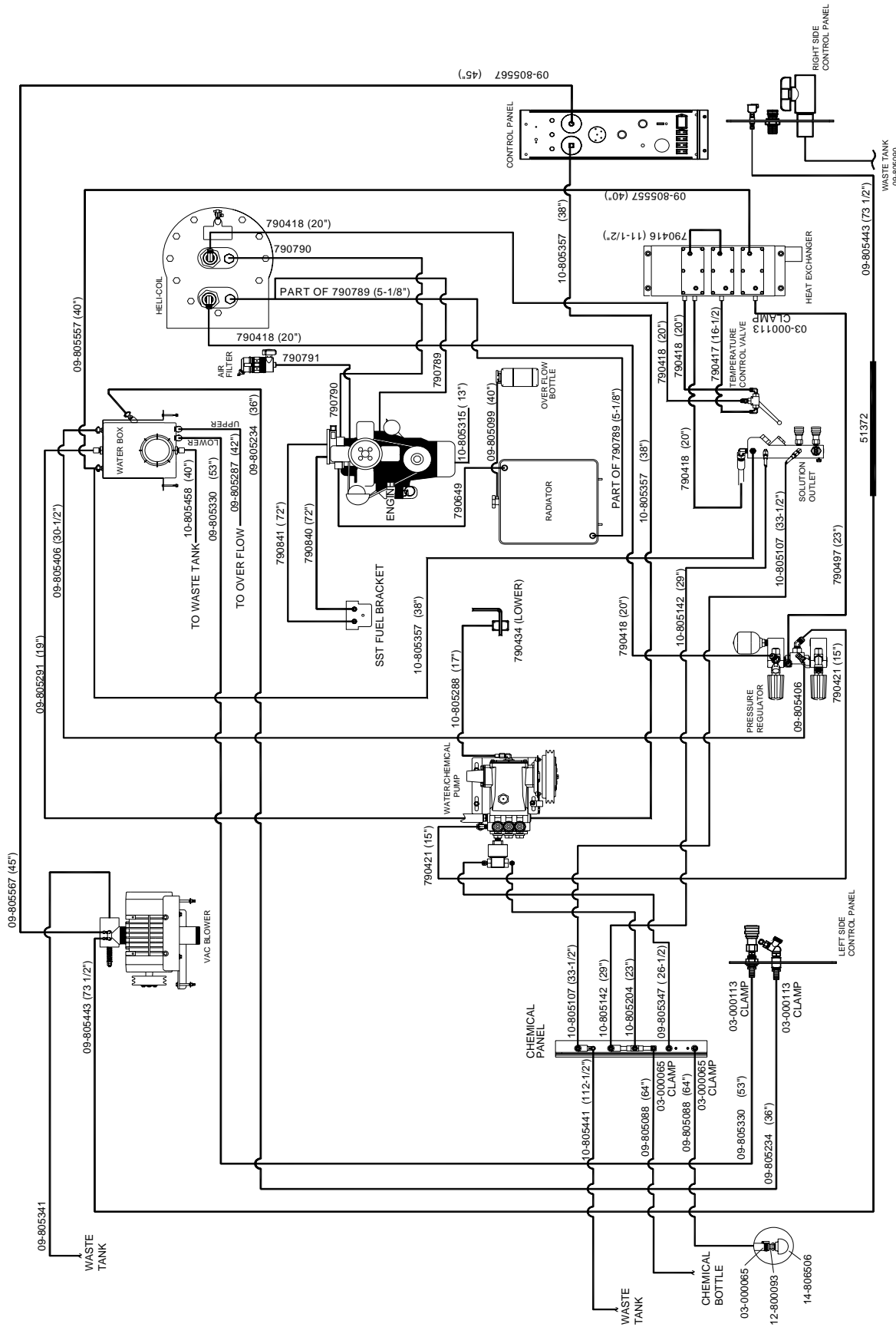



# LIMITED WARRANTY

## Emission Components (Non-California Engine)

Zenith Power Products LLC (“ZPP”) warrants the emission components on your new ZPP industrial engine as follows:

**DEFINITION:** As used in this warranty, “Engine” means a new ZPP Engine sold and delivered by an authorized ZPP engine Distributor, or Original Equipment Manufacturer (any of which is called a “Seller”) to the original retail purchaser, for use in all states of the United States except California, including only those approved Nissan and ZPP parts and accessories originally included as part of the new engine. The emission-related warranty covers components whose failure would increase an engine’s emissions, including electronic controls, fuel injection (for liquid or gaseous fuels), exhaust-gas recirculation, aftertreatment, or any other system developed to control emissions. The replacing or repairing of other components is the owner’s responsibility.

Emissions Components does not include the OEM catalytic converter and/or the catalytic muffler.

**WARRANTY:** ZPP warrants to the original retail purchaser that: (i) the Engine is designed, built and equipped to conform, at the time of sale, with U.S. Environmental Protection Agency (“EPA”) regulations governing emissions from large nonroad spark-ignition engines; (ii) the Engine is free from defects in materials and workmanship that would keep the Engine from meeting those EPA requirements; and (iii) the Seller, on behalf of ZPP, will, during the warranty period, repair or replace (at ZPP’s option) any Emission Component(s) that malfunction(s) in use and service due to defects in material or workmanship. As used in this paragraph, “malfunction” means that the Engine is unable to comply, in ordinary operation, with EPA’s large nonroad spark-ignition engine requirements.

**WARRANTY PERIOD:** The warranty period shall begin on the delivery date of the Engine to the original retail purchaser and shall continue thereafter for a period of 3 years or 2,500 hours, whichever comes first; provided, however, that the warranty period for the throttle body shall begin on the delivery date of the Engine to the original retail purchaser and shall continue thereafter for a period of 5 years or 3,500 hours, whichever comes first

**CLAIMS:** All claims under this warranty shall be made to Seller, who shall perform the repair. Products repaired or replaced under this warranty are warranted herein for the unexpired portion of the original warranty.

### EXCLUSIONS:

A. In no event shall ZPP be liable for loss of time, inconvenience, and loss of use of the Engine, damage to persons or property, or any other incidental or consequential damages. In no event shall the maximum liability of ZPP under this warranty exceed the purchaser’s cost of the Engine.

B. The obligation and liability under this warranty is limited to the repair or replacement, at the option of ZPP, of any emission control parts, components, or system listed above. The ZPP warranty does not provide for any labor or travel expenditure associated with defective parts, components or system except where required by law.

C. This warranty does not cover:

- 1) Any parts or accessories installed on the Engine that were not manufactured or installed by ZPP or Nissan (including, without limitation, batteries, alternators or starters). Such parts and accessories may be covered by a warranty from the manufacturer of said item.
- 2) Any defect in the Engine which was caused (in ZPP’s sole judgment) by other than normal use and service or by any misuse, negligence, fuel contamination, overloading, accident, abuse, alteration, unsuitable storage, immersion or submersion, or use other than in accordance with the Engine’s rated capacity and use.
- 3) Any adverse effect on the Engine caused by repair by other than an authorized ZPP repair facility or with parts or supplies not manufactured or supplied by ZPP or Nissan.
- 4) Any Engine whose serial number has been altered or removed or on which recommended maintenance and inspections have not been performed.
- 5) Normal maintenance and inspection, such as tune-up, tightening of nuts, bolts, screws, replacement of belts, etc.
- 6) Selection or installation of the Engine for other than its intended use, or if performed by someone other than the Seller.

D. ZPP shall not be obligated or liable under this warranty in the event you fail to use the OEM catalytic converter and catalytic muffler, as designated by ZPP, or its agents, dealers, or distributors, for use with the Engine.

**DISCLAIMER OF IMPLIED WARRANTIES.** THIS IS THE ONLY WARRANTY WHICH ZPP MAKES FOR EMISSION COMPONENTS OF ITS ENGINES. ALL IMPLIED WARRANTIES, INCLUDING WARRANTIES OF MERCHANTABILITY AND WARRANTIES OF FITNESS FOR A PARTICULAR PURPOSE, ARE SPECIFICALLY EXCLUDED.

ENGINE MODEL	CUSTOMER NAME	TYPE OF EQUIPMENT
SERIAL NUMBER	CUSTOMER CITY, STATE ZIP	MAKE / MODEL
DELIVERY DATE	CUSTOMER COUNTY	MANUFACTURER’S NAME
DISTRIBUTOR NAME	CUSTOMER SIGNATURE	DISTRIBUTOR’S SIGNATURE

RETURN COMPLETED COPY OF CERTIFICATE TO ZENITH POWER PRODUCTS WITHIN 15 DAYS FROM DATE OF RECEIVING THIS CERTIFICATE.

Return To:  
ZENITH POWER PRODUCTS LLC  
14570 INDUSTRIAL PARK ROAD  
BRISTOL, VA 24202  
ATTN: CUSTOMER SERVICE DEPARTMENT

WHITE – CUSTOMER COPY    CANARY – ZPP COPY    PINK – DISTRIBUTOR COPY



## **Emission Warranty Parts List**

1. Fuel Metering System
  - a. Fuel injection system
  - b. Air/fuel ratio feedback and control system
2. Air Induction System
  - a. Intake manifold
3. Catalyst system
  - a. Catalytic converter
  - b. Exhaust manifold
4. Positive Crankcase Ventilation (PCV) System
  - a. PCV valve
  - b. Oil filler cap
5. Ignition and Electronic Control System
  - a. Electronic Control Module (ECM)
  - b. Distributor
  - c. Ignition coil
6. Miscellaneous Items Used in Above Systems
  - a. Electronic control sensors
  - b. Hoses , belts, connectors, assemblies, clamps, fittings, tubing  
sealing gaskets or devices and mounting hardware
  - c. Pulleys, belts and idlers

### **Emissions Warranty "High Priced" Parts List**

Throttle Body Assembly with ECM  
Throttle Body Assembly without ECM



# **ZENITH POWER PRODUCTS 2004 ENGINE WARRANTY PACKAGE**

## INTRODUCTION

This Introduction, along with the three (3) attached warranty certificates, together comprise the warranty package for your new Zenith Power Products (ZPP) engine. The various components of your ZPP engine are covered by one or more of the attached warranties, depending on the particular part manufacturer, the engine purchase date, and/or the engine's location. The purpose of this Introduction, which is not itself a warranty, is to explain how and when the various warranties apply. Please read this Introduction carefully and follow these directions for any warranty claims.

- **Engine Emission Components:** Your new ZPP engine has been designed, manufactured and certified to comply with recently adopted federal anti-smog standards, which require *that certain components* be covered by either a 3-year/2,500 hour or a 5-year/3,500 hour warranty, depending on the component. If you use your ZPP engine in any U.S. state other than California, the emission-related warranty will cover components whose failure would increase an engine's emissions, including electronic controls, fuel injection (for liquid or gaseous fuels), exhaust-gas recirculation, aftertreatment, or any other system developed to control emissions. The replacing or repairing of other components is the owner's responsibility.
  
- **Catalytic Converter and Catalytic Muffler** – The OEM- or Dealer-installed catalytic converter and/or catalytic muffler on your ZPP engine are manufactured by DCL International Inc. These components are subject to federal and state warranty requirements, and warranty claims are administered directly by ZPP. All warranty claims must be made to ZPP LLC, Customer Service Department.
  
- **Engine Warranty** – Regardless of where you use your engine, the ZPP engine will be covered by the *ZPP 12 months engine* “limited warranty”
  
- **California Engine Emission Components** - Your new ZPP engine has been designed, manufactured, and certified to comply with California state anti-smog standards, which require *certain emission-related components* be covered by either a three (3) year/2,500 hour or five (5) year/3,500 hour warranty. If you use your ZPP engine in California, the following emission-related parts of the engine are covered by the attached California Air Resources Board warranty, “YOUR WARRANTY RIGHTS AND OBLIGATIONS:”
  - Fuel Injection System
  - Air/Fuel Ratio Feedback
  - Electronic Control Module and Sensors
  - Catalytic Converter
  - Intake Manifold
  - Exhaust Manifold
  - PCV Valve
  - Oil Filler Cap
  - Distributor
  - Ignition Coil
  - Miscellaneous Parts In Systems listed above, including: hoses, belts, connectors, assemblies, clamps, fittings, tubing, sealing gaskets or devices, mounting hardware, pulleys, belts, and idlers
  - Throttle Body Assembly

Several warranties included in this Warranty Package require that you, as the original retail purchaser, timely complete and submit copies of the warranty certificates to ZPP, for purposes of registration. Please complete the required registration information and submit the designated copies to ZPP. Failure to submit the required registration could delay or prejudice your warranty claim.

IN THE EVENT OF A WARRANTY CLAIM, IT IS YOUR RESPONSIBILITY TO INITIATE THE CLAIM BY TAKING YOUR ZPP ENGINE TO AN AUTHORIZED ZPP DISTRIBUTOR OR, IF YOUR ZPP ENGINE CAME INSTALLED IN ANY VEHICLE OR OFF-ROAD PIECE OF EQUIPMENT, TO THE ORIGINAL EQUIPMENT MANUFACTURER. FAILURE TO TIMELY INITIATE YOUR CLAIM MAY PREJUDICE YOUR RIGHT TO PROTECTION UNDER THE WARRANTIES.

EACH OF THE ATTACHED WARRANTIES LISTS APPLICABLE EXCLUSIONS. PLEASE READ THESE CAREFULLY AND BECOME FAMILIAR WITH THEM.

**If you have any questions regarding your warranty rights or responsibilities, you should contact Zenith Power Products at 1-276-669-5555.**



**YOUR WARRANTY RIGHTS AND OBLIGATIONS**

The **California Air Resources Board**, the **U.S. Environmental Protection Agency** and **Zenith Power Products LLC** is pleased to explain the emission control system warranty on your 2004 Nissan 1.3L, 1.5L, 2.0L or 2.5L engine. In all states, new off-road large spark-ignition (LSI) engines must be designed, built and equipped to meet stringent anti-smog standards. Zenith Power Products must warrant the emission control system on your engine for the periods of time listed below provided there has been no abuse, neglect or improper maintenance of your engine.

Your emission control system may include parts such as the carburetor, regulator or fuel injection system, ignition system, engine computer unit (ECM), catalytic converter and air induction system. Also included may be sensors, hoses, belts, connectors and other emission-related assemblies.

Where a warrantable condition exists, Zenith Power Products will repair your LSI engine at no cost to you including diagnosis, parts and labor.

**MANUFACTURER'S WARRANTY COVERAGE:**

The 2004 off-road large spark-ignition engines are warranted for **3 years or 2,500 hours**. If any emission-related part on your engine is defective, the part will be repaired or replaced by Zenith Power Products. In addition to the general warranty coverage, the following items are identified as "high priced"  
 Throttle Body Assembly without ECM  
 Throttle Body Assembly with ECM  
 The "high priced" items are warranted for **5 years or 3,500 hours whichever comes first**.

**OWNER'S WARRANTY RESPONSIBILITIES:**

- As the off-road LSI engine owner, you are responsible for the performance of the required maintenance listed in your owner's manual. Zenith Power Products recommends that you retain all receipts covering maintenance on your off-road engine, but Zenith Power Products cannot deny warranty solely for the lack of receipts or for your failure to ensure the performance of all scheduled maintenance.
- As the off-road large spark-ignition engine owner, you should however be aware that Zenith Power Products may deny you warranty coverage if your off-road large spark-ignition engine or a part has failed due to abuse, neglect, improper maintenance or unapproved modifications.
- Your engine is designed to operate on unleaded gasoline or LPG only. Use of any other fuel may result in your engine no longer operating in compliance with California's emissions requirements.
- You are responsible for initiating the warranty process, the ARB suggests that you present your off-road large spark-ignition engine to the original vehicle dealer as soon as a problem exists. The warranty repairs should be completed by the dealer as expeditiously as possible.

If you have any questions regarding your warranty rights or responsibilities, you should contact Zenith Power Products at **1-276-669-5555**.

_____ ENGINE MODEL	_____ CUSTOMER NAME	_____ TYPE OF EQUIPMENT
_____ SERIAL NUMBER	_____ CUSTOMER CITY, STATE ZIP	_____ MAKE / MODEL
_____ DELIVERY DATE	_____ CUSTOMER COUNTY	_____ MANUFACTURER'S NAME
_____ DISTRIBUTOR NAME	_____ CUSTOMER SIGNATURE	_____ DISTRIBUTOR'S SIGNATURE

RETURN COMPLETED COPY OF CERTIFICATE TO ZENITH POWER PRODUCTS WITHIN 15 DAYS FROM DATE OF RECEIVING THIS CERTIFICATE.

Return To:  
 ZENITH POWER PRODUCTS LLC  
 14570 INDUSTRIAL PARK ROAD  
 BRISTOL, VA 24202  
 ATTN: CUSTOMER SERVICE DEPARTMENT

WHITE - CUSTOMER COPY    CANARY - ZPP COPY    PINK - DISTRIBUTOR COPY



# ENGINE LIMITED WARRANTY

Zenith Power Products LLC (ZPP) warrants each new ZPP industrial engine as follows:

**DEFINITION:** As used in this warranty, "Engine" means a new ZPP Engine sold and delivered by an authorized ZPP engine Distributor ("Seller") to the original retail purchaser, including only those approved ZPP parts and accessories originally included as part of the new engine.

**WARRANTY:** ZPP warrants to the original retail purchaser that the Seller, on behalf of ZPP, will, during the warranty period, repair or replace (at ZPP's option) any engine parts[s] which malfunction due to defect in material or workmanship.

**WARRANTY PERIOD:** The warranty period shall begin on the delivery date of the Engine to the original retail purchaser and shall end twelve months following said delivery date.

**CLAIMS:** All claims under this warranty shall be made to Seller, who shall perform the repair.

**EXCLUSIONS:**

A. In no event shall ZPP be liable for loss of time, inconvenience, loss of use of the Engine, damage to persons or property, or any other incidental or consequential damage. In no event shall the maximum liability of ZPP under this warranty exceed the purchaser's cost of the Engine.

B. This warranty does not cover:

1) Any parts or accessories installed on the Engine which were not manufactured or installed by ZPP (including, without limitation, manifolds, batteries, alternators or starters). Such parts and accessories may be covered by a warranty from the manufacturer of said item.

2) Any defect in the Engine which was caused (in ZPP's sole judgment) by other than normal use and service or by any misuse, negligence, fuel contamination, overloading, accident, abuse, alternation, unsuitable storage, immersion or submersion, or use other than in accordance with the Engine's rated capacity and use.

3) Any adverse effect on the Engine caused by repair by other than an authorized ZPP repair facility or with parts or supplies not manufactured or supplied by ZPP.

4) Any Engine whose serial number has been altered or removed or on which recommended maintenance and inspections have not been performed.

5) Normal maintenance and inspection, such as tune-up, tightening of nuts, bolts, screws, replacement of belts, etc.

6) Selection or installation of the Engine for its intended use, if performed by someone other than the Seller.

**DISCLAIMER OF IMPLIED WARRANTIES.** THIS IS THE ONLY WARRANTY WHICH ZPP MAKES FOR ENGINES. ALL IMPLIED WARRANTIES, INCLUDING WARRANTIES OF MERCHANTABILITY AND WARRANTIES OF FITNESS FOR A PARTICULAR PURPOSE, ARE SPECIFICALLY EXCLUDED.

ENGINE MODEL

CUSTOMER NAME

TYPE OF EQUIPMENT

SERIAL NUMBER

CUSTOMER CITY, STATE ZIP

MAKE / MODEL

DELIVERY DATE

CUSTOMER COUNTY

MANUFACTURER'S NAME

DISTRIBUTOR NAME

CUSTOMER SIGNATURE

DISTRIBUTOR'S SIGNATURE

RETURN COMPLETED COPY OF CERTIFICATE TO ZENITH POWER PRODUCTS WITHIN 15 DAYS FROM DATE OF RECEIVING THIS CERTIFICATE.

Return To:  
ZENITH POWER PRODUCTS LLC  
14570 INDUSTRIAL PARK ROAD  
BRISTOL, VA 24202  
ATTN: CUSTOMER SERVICE DEPARTMENT

WHITE - CUSTOMER COPY    CANARY - ZPP COPY    PINK - DISTRIBUTOR COPY